



## DESCRIPTION

For switching and amplifier applications. Especially suitable for AF-driver stages and low power output stages.

The SS8050 is available in SOT-23 package.

## ORDERING INFORMATION

Package Type	Part Number
SOT-23	SS8050
Note	SPQ: 3,000pcs/Reel
AiT provides all RoHS Compliant Products	

## FEATURES

- Available in SOT-23 package

## PIN DESCRIPTION

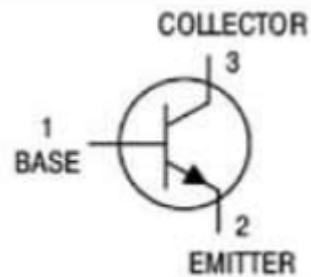
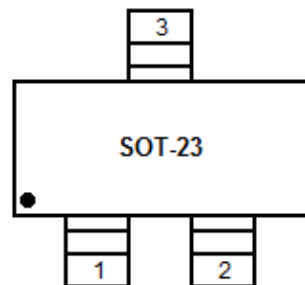



## ABSOLUTE MAXIMUM RATINGS

T<sub>A</sub>=25°C

V <sub>CB0</sub> , Collector Base Voltage	40V
V <sub>CEO</sub> , Collector Emitter Voltage	25V
V <sub>EBO</sub> , Emitter Base Voltage	6V
I <sub>C</sub> , Collector Current	1.5A
P <sub>tot</sub> , Power Dissipation	350mW
T <sub>J</sub> , Junction Temperature	150°C
T <sub>STG</sub> , Storage Temperature Range	-55°C ~ 150°C

Stresses above may cause permanent damage to the device. These are stress ratings only and functional operation of the device at these or any other conditions beyond those indicated in the Electrical Characteristics are not implied. Exposure to absolute maximum rating conditions for extended periods may affect device reliability.

## ELECTRICAL CHARACTERISTICS

T<sub>A</sub> = 25°C

Parameter	Symbol	Conditions	Min.	Typ.	Max.	Unit
DC Current Gain	h <sub>FE</sub>	V <sub>CE</sub> = 1V, I <sub>C</sub> = 100mA	200	-	350	-
		V <sub>CE</sub> = 1V, I <sub>C</sub> = 800mA				
Collector Base Cutoff Current	I <sub>CB0</sub>	V <sub>CB</sub> = 35V	-	-	100	nA
Emitter Base Cutoff Current	I <sub>EBO</sub>	V <sub>EB</sub> = 6V	-	-	100	nA
Collector Base Breakdown Voltage	V <sub>(BR)CBO</sub>	I <sub>C</sub> = 100μA	40	-	-	V
Collector Emitter Breakdown Voltage	V <sub>(BR)CEO</sub>	I <sub>C</sub> = 2mA	25	-	-	V
Emitter Base Breakdown Voltage	V <sub>(BR)EBO</sub>	I <sub>E</sub> = 100μA	6	-	-	V
Collector Emitter Saturation Voltage	V <sub>CE(sat)</sub>	I <sub>C</sub> = 800mA, I <sub>B</sub> = 80mA	-	-	0.5	V
Base Emitter Saturation Voltage	V <sub>BE(Sat)</sub>	I <sub>C</sub> = 800mA, I <sub>B</sub> = 80mA	-	-	1.2	V
Base Emitter Voltage	V <sub>BE(on)</sub>	V <sub>CE</sub> = 1V, I <sub>C</sub> = 10mA	-	-	1	V
Gain Bandwidth Product	f <sub>T</sub>	V <sub>CE</sub> = 10V, I <sub>C</sub> = 50mA	120	-	-	MHz



## TYPICAL CHARACTERISTICS

Figure 1.  $I_C - V_{CE}$

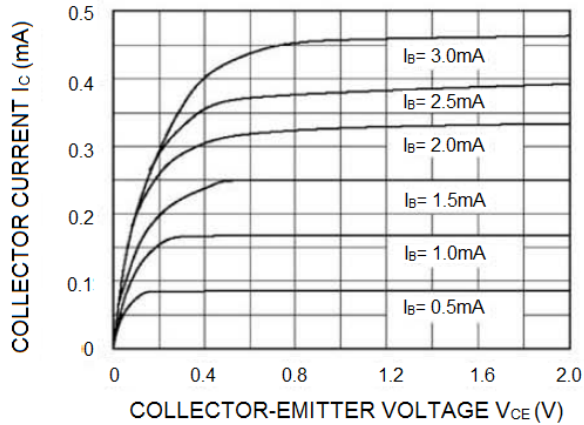

Figure 2.  $h_{FE} - I_C$

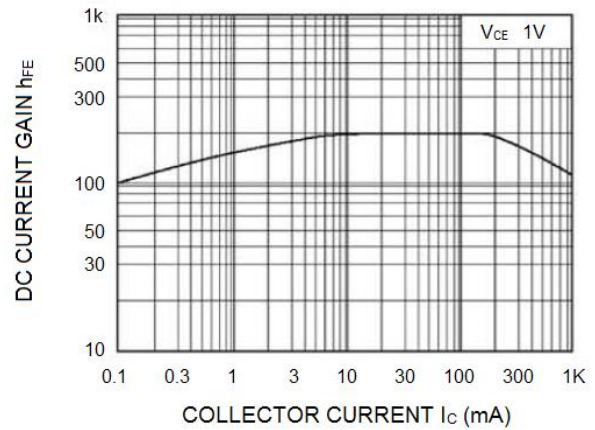

Figure 3.  $I_C - V_{BE}$

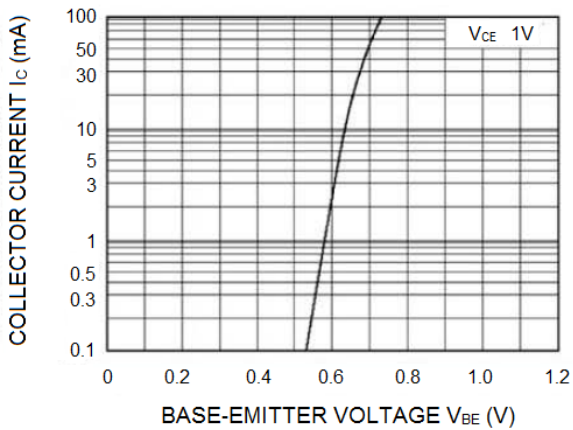

Figure 4.  $V_{BE(sat)}, V_{CE(sat)} - I_C$

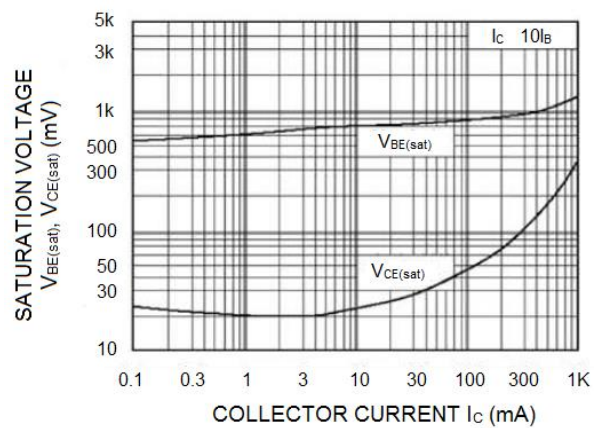

Figure 5.  $f_T - I_C$

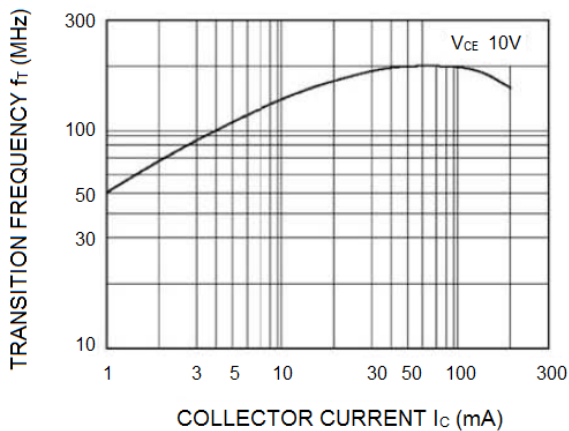

Figure 6.  $C_{ob} - V_{CB}$

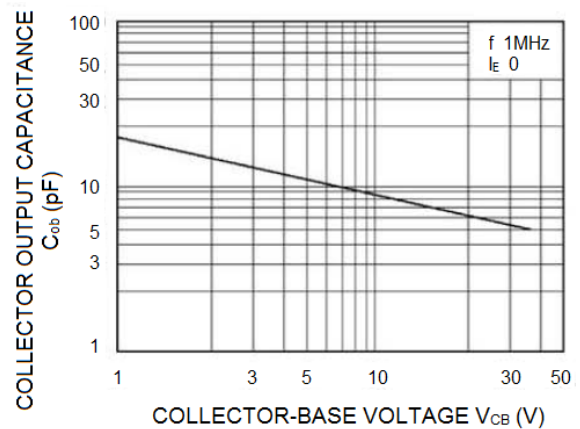
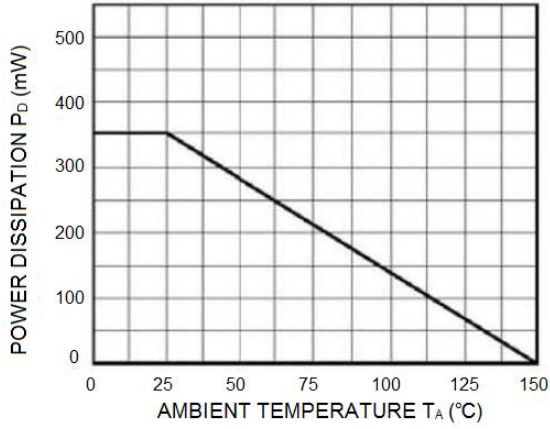

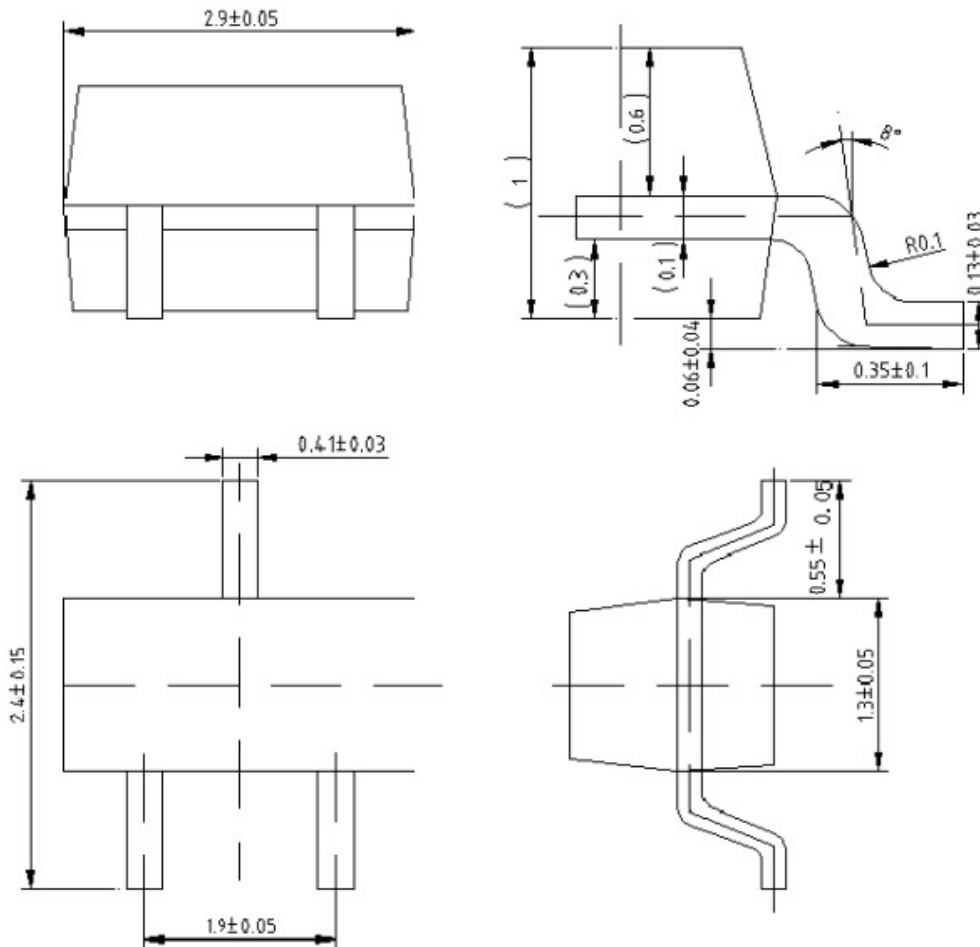

Figure 7.  $P_D - T_A$



## PACKAGE INFORMATION

Dimension in SOT-23 Package (Unit: mm)





## IMPORTANT NOTICE

AiT Semiconductor Inc. (AiT) reserves the right to make changes to any its product, specifications, to discontinue any integrated circuit product or service without notice, and advises its customers to obtain the latest version of relevant information to verify, before placing orders, that the information being relied on is current.

AiT Semiconductor Inc.'s integrated circuit products are not designed, intended, authorized, or warranted to be suitable for use in life support applications, devices or systems or other critical applications. Use of AiT products in such applications is understood to be fully at the risk of the customer. As used herein may involve potential risks of death, personal injury, or severe property, or environmental damage. In order to minimize risks associated with the customer's applications, the customer should provide adequate design and operating safeguards.

AiT Semiconductor Inc. assumes to no liability to customer product design or application support. AiT warrants the performance of its products of the specifications applicable at the time of sale.