



## DESCRIPTION

The AO321V have a high gain-bandwidth product of 1MHz, a slew rate of 0.6V/μs, and a quiescent current of 40μA/amplifier at 5V. The AO321V is designed to provide optimal performance in low voltage and low noise systems. They provide rail-to-rail output swing into heavy loads. The input common mode voltage range includes ground, and the maximum input offset voltage is 3.5mV for AO321V. They are specified over the extended industrial temperature range (-40°C to +125°C). The operating range is from 2.1V to 5.5V.

The AO321V (single) is available in SOT-25 package.

## ORDERING INFORMATION

Package Type	Part Number	
SOT-25 SPQ: 3,000pcs/Reel	E5	AO321VE5R
		AO321VE5VR
Note	V: Halogen free Package R: Tape & Reel	
AiT provides all RoHS products		

## FEATURES

- Single-Supply Operation from +2.1V ~ +5.5V
- Rail-to-Rail Input / Output
- Gain-Bandwidth Product: 1MHz (Typ.)
- Low Input Bias Current: 1pA (Typ.)
- Low Offset Voltage: 3.5mV (Max.)
- Quiescent Current: 40μA per Amplifier (Typ.)
- Operating Temperature: -40°C ~ +125°C
- Embedded RF Anti-EMI Filter
- Available in SOT-25 package

## APPLICATION

- ASIC Input or Output Amplifier
- Sensor Interface
- Medical Communication
- Smoke Detectors
- Audio Output
- Piezoelectric Transducer Amplifier
- Medical Instrumentation
- Portable Systems

## TYPICAL APPLICATION

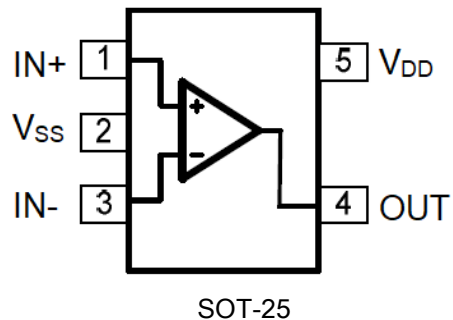



## PIN DESCRIPTION

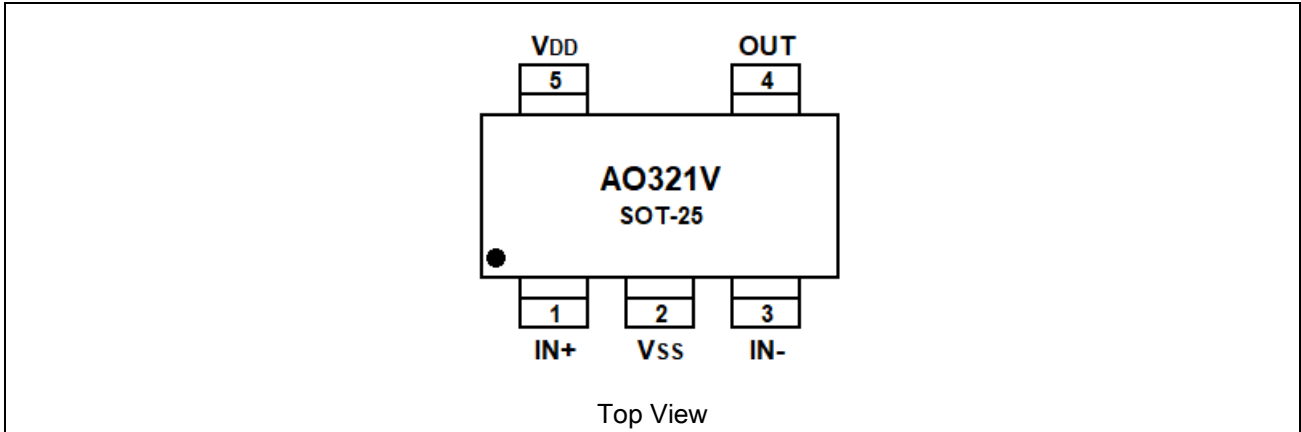

Pin #	Symbol	Function
1	IN+	Analog Positive Input
2	V <sub>SS</sub>	Ground or Negative Power Supply Input
3	IN-	Analog Inverting Input
4	OUT	Output
5	V <sub>DD</sub>	Positive Power Supply Input



## ABSOLUTE MAXIMUM RATINGS

Power Supply Voltage ( $V_{DD}$ to $V_{SS}$ )	-0.5V~+7.5V
Analog Input Voltage (IN+ or IN-)	$V_{SS}-0.5V\sim V_{DD}+0.5V$
PDB Input Voltage	$V_{SS}-0.5V\sim +7V$
Operating Temperature Range	-40°C~+125°C
Junction Temperature	+160°C
Storage Temperature Range	-55°C~+150°C
Lead Temperature (soldering, 10sec)	+260°C
<b>Package Thermal Resistance (<math>T_A=+25^\circ\text{C}</math>)</b>	
$\theta_{JA}$ , SOT25	190°C/W
<b>ESD Susceptibility</b>	
HBM	6kV
MM	300V

Stress beyond above listed "Absolute Maximum Ratings" may lead permanent damage to the device. These are stress ratings only and operations of the device at these or any other conditions beyond those indicated in the operational sections of the specifications are not implied. Exposure to absolute maximum rating conditions for extended periods may affect device reliability.



## ELECTRICAL CHARACTERISTICS

At  $V_S = +5V$ ,  $R_L = 100k\Omega$  connected to  $V_S/2$ , and  $V_{OUT} = V_S/2$ , unless otherwise noted.

Parameter	Symbol	Conditions	Typ	Min/Max Over Temperature			Unit	Min / Max
			+25°C	+25°C	-40°C to +85°C			
<b>INPUT CHARACTERISTICS</b>								
Input Offset Voltage	$V_{OS}$	$V_{CM} = V_S/2$	0.4	3.5	5.6	mV	Max	
Input Bias Current	$I_B$		1	-	-	pA	Typ	
Input Offset Current	$I_{OS}$		1	-	-	pA	Typ	
Common-Mode Voltage Range	$V_{CM}$	$V_S = 5.5V$	-0.1 to +5.6	-	-	V	Typ	
Common-Mode Rejection Ratio	CMRR	$V_S = 5.5V$ , $V_{CM} = -0.1V$ to $4V$	70	62	62	dB	Min	
		$V_S = 5.5V$ , $V_{CM} = -0.1V$ to $5.6V$	68	56	55			
Open-Loop Voltage Gain	$A_{OL}$	$R_L = 5k\Omega$ , $V_O = +0.1V$ to $+4.9V$	80	70	70	dB	Min	
		$R_L = 10k\Omega$ , $V_O = +0.1V$ to $+4.9V$	100	94	85			
Input Offset Voltage Drift	$\Delta V_{OS}/\Delta T$		2.7	-	-	$\mu V/^\circ C$	Typ	
<b>OUTPUT CHARACTERISTICS</b>								
Output Voltage Swing from Rail	$V_{OH}$	$R_L = 100k\Omega$	4.997	4.990	4.980	V	Min	
	$V_{OL}$	$R_L = 100k\Omega$	3	10	20	mV	Max	
	$V_{OH}$	$R_L = 10k\Omega$	4.992	4.970	4.960	V	Min	
	$V_{OL}$	$R_L = 10k\Omega$	8	30	40	mV	Max	
Output Current	$I_{SOURCE}$	$R_L = 10\Omega$ to $V_S/2$	84	60	45	mA	Min	
	$I_{SINK}$		75	60	45			
<b>POWER SUPPLY</b>								
Operating Voltage Range			-	2.1	2.5	V	Min	
			-	5.5	5.5	V	Max	
Power Supply Rejection Ratio	PSRR	$V_S = +2.5V$ to $+5.5V$ , $V_{CM} = +0.5V$	82	60	58	dB	Min	
Quiescent Current/Amplifier	$I_Q$		40	-	-	$\mu A$	Typ	



Parameter	Symbol	Conditions	Typ	Min/Max Over Temperature			
			+25°C	+25°C	-40°C to +85°C	Unit	Min / Max
<b>DYNAMIC PERFORMANCE (C<sub>L</sub> = 100pF)</b>							
Gain-Bandwidth Product	GBP		1	-	-	MHz	Typ
Slew Rate	SR	G = +1, 2V Output Step	0.6	-	-	V/μs	Typ
Settling Time to 0.1%	t <sub>s</sub>	G = +1, 2V Output Step	5	-	-	μs	Typ
Overload Recovery Time		V <sub>IN</sub> · Gain = V <sub>S</sub>	2.6	-	-	μs	Typ
<b>NOISE PERFORMANCE</b>							
Voltage Noise Density	e <sub>n</sub>	f = 1kHz	27	-	-	nV/ √Hz	Typ
		f = 10kHz	20	-	-	nV/ √Hz	Typ



## TYPICAL PERFORMANCE CHARACTERISTICS

At  $T_A=+25^\circ\text{C}$ ,  $V_S=+5\text{V}$ , and  $R_L=100\text{k}\Omega$  connected to  $V_S/2$ , unless otherwise noted.

### 1. Large-Signal Step Response

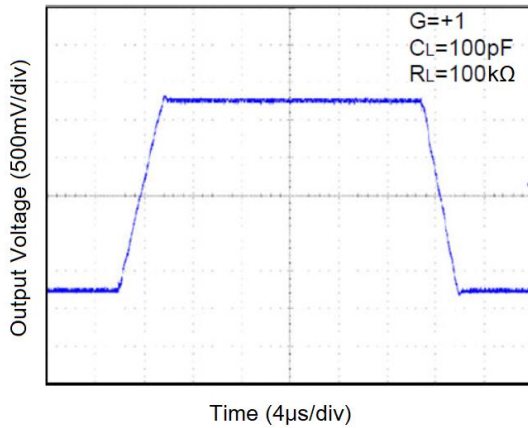

### 2. Small-Signal Step Response

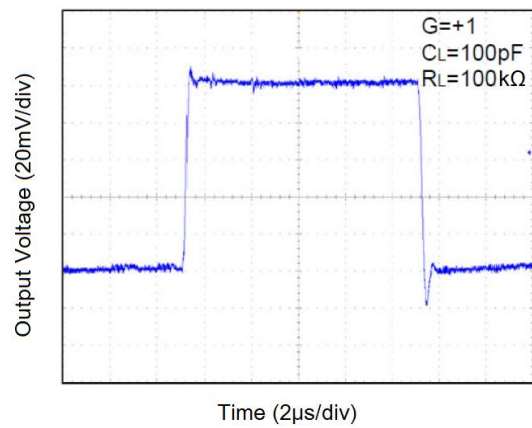

### 3. Supply Current vs. Supply Voltage

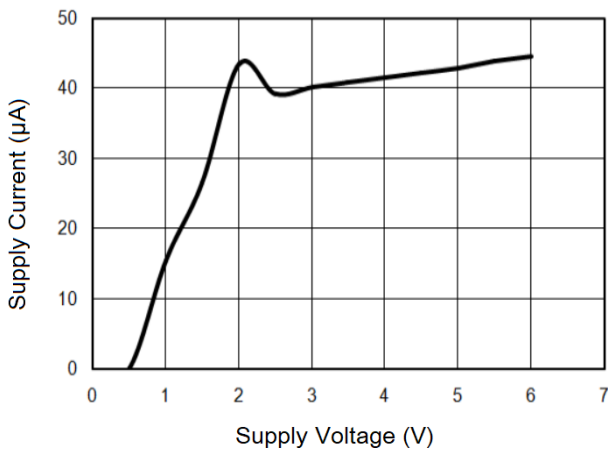

### 4. Short-Circuit Current vs. Supply Voltage

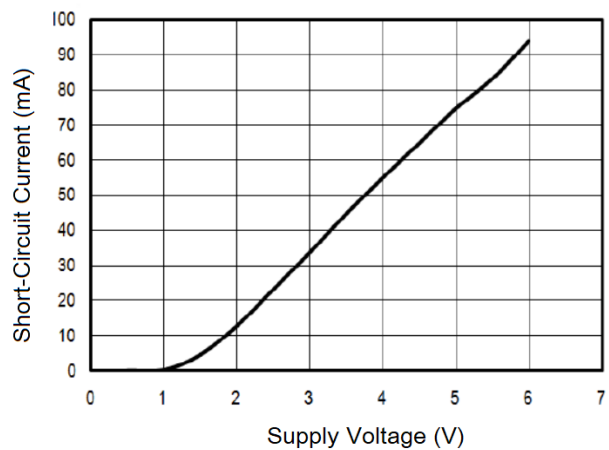

### 5. Output Voltage vs. Output Current

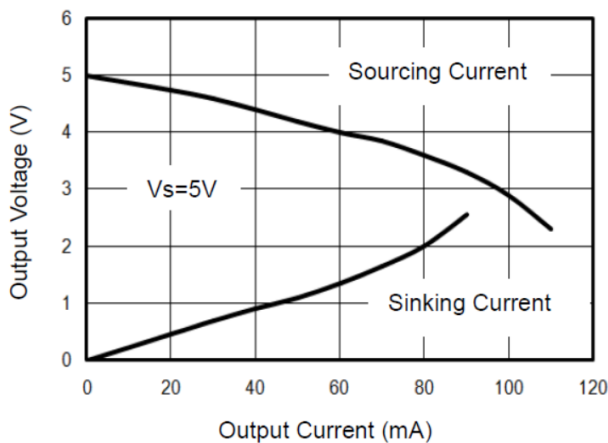

### 6. Output Voltage vs. Output Current

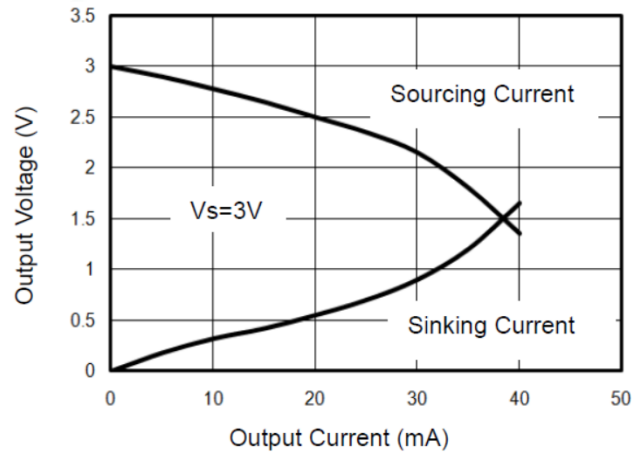



7. Overload Recovery Time

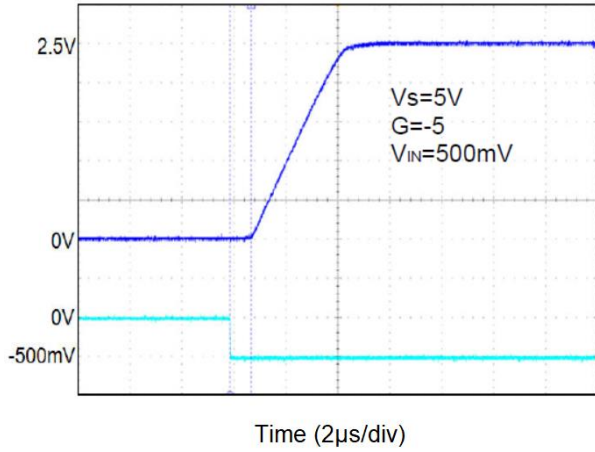

8. Supply Current vs. Temperature

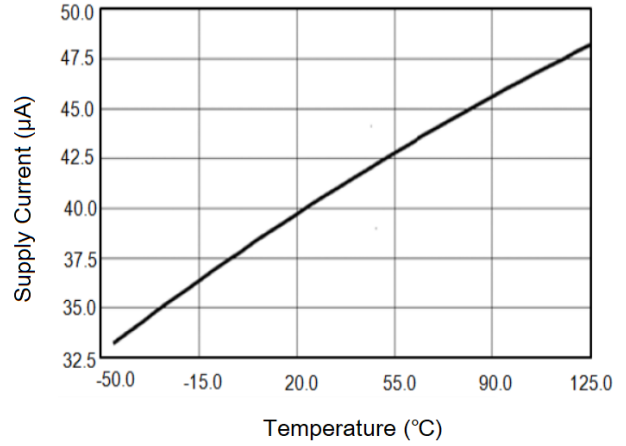

9. Input Voltage Noise Spectral Density vs. Frequency

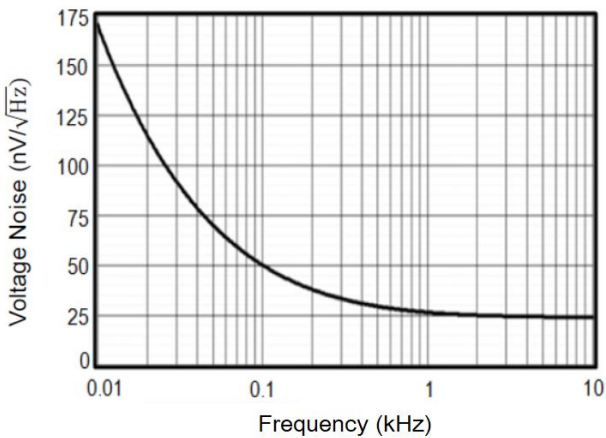

10. Open Loop Gain, Phase Shift vs. Frequency at +5V

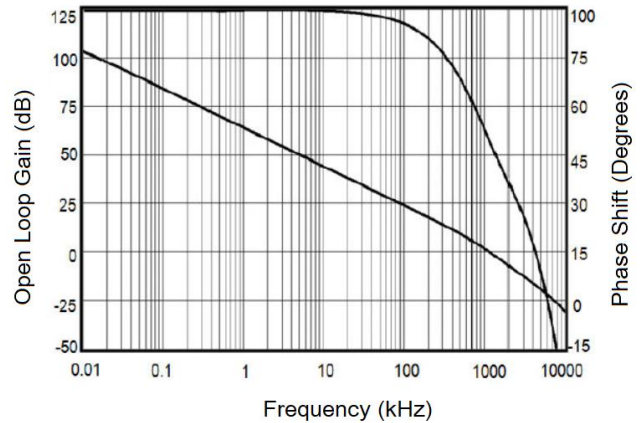

11. CMRR vs. Frequency

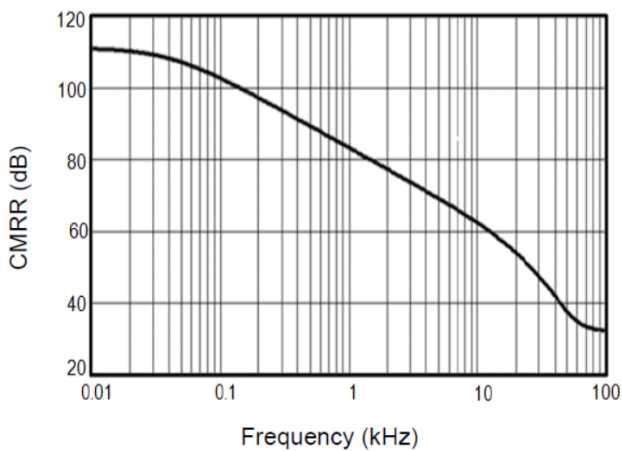

12. PSRR vs. Frequency

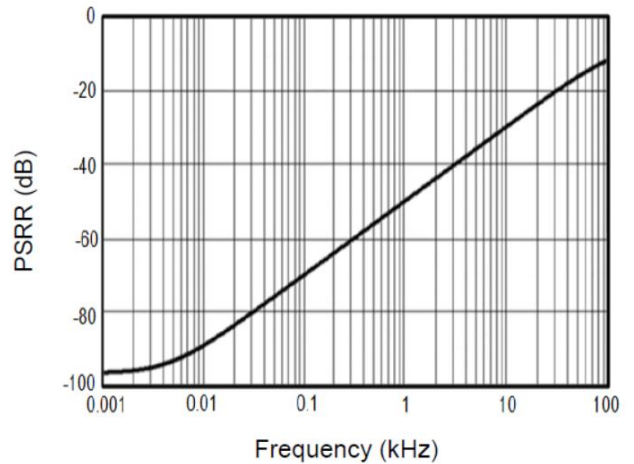



## DETAILED INFORMATION

### Size

AO321V op amps are unity-gain stable and suitable for a wide range of general-purpose applications. The small footprints of the AO321V packages save space on printed circuit boards and enable the design of smaller electronic products.

### Power Supply Bypassing and Board Layout

AO321V operates from a single 2.1V to 5.5V supply or dual  $\pm 1.05\text{V}$  to  $\pm 2.75\text{V}$  supplies. For best performance, a 0.1 $\mu\text{F}$  ceramic capacitor should be placed close to the  $V_{\text{DD}}$  pin in single supply operation. For dual supply operation, both  $V_{\text{DD}}$  and  $V_{\text{SS}}$  supplies should be bypassed to ground with separate 0.1 $\mu\text{F}$  ceramic capacitors.

### Low Supply Current

The low supply current (typical 40 $\mu\text{A}$  per channel) of AO321V will help to maximize battery life. They are ideal for battery powered systems

### Operating Voltage

AO321V operates under wide input supply voltage (2.1V to 5.5V). In addition, all temperature specifications apply from  $-40^{\circ}\text{C}$  to  $+125^{\circ}\text{C}$ . Most behavior remains unchanged throughout the full operating voltage range. These guarantees ensure operation throughout the single Li-Ion battery lifetime

### Rail-to-Rail Input

The input common-mode range of AO321V extends 100mV beyond the supply rails ( $V_{\text{SS}}-0.1\text{V}$  to  $V_{\text{DD}}+0.1\text{V}$ ). This is achieved by using complementary input stage. For normal operation, inputs should be limited to this range.

### Rail-to-Rail Output

Rail-to-Rail output swing provides maximum possible dynamic range at the output. This is particularly important when operating in low supply voltages. The output voltage of AO321V can typically swing to less than 5mV from supply rail in light resistive loads ( $>100\text{k}\Omega$ ), and 30mV of supply rail in moderate resistive loads (10k $\Omega$ ).





### Capacitive Load Tolerance

The AO321V is optimized for bandwidth and speed, not for driving capacitive loads. Output capacitance will create a pole in the amplifier's feedback path, leading to excessive peaking and potential oscillation. If dealing with load capacitance is a requirement of the application, the two strategies to consider are (1) using a small resistor in series with the amplifier's output and the load capacitance and (2) reducing the bandwidth of the amplifier's feedback loop by increasing the overall noise gain. Figure 1. shows a unity gain follower using the series resistor strategy. The resistor isolates the output from the capacitance and, more importantly, creates a zero in the feedback path that compensates for the pole created by the output capacitance.

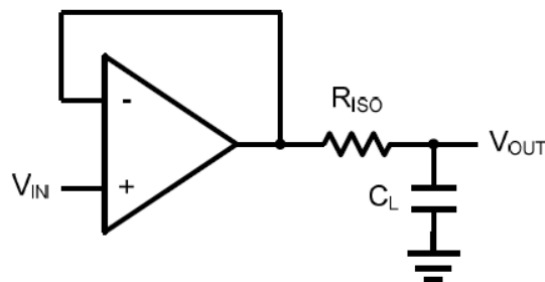

Figure 1. Indirectly Driving a Capacitive Load Using Isolation Resistor

The bigger the  $R_{ISO}$  resistor value, the more stable  $V_{OUT}$  will be. However, if there is a resistive load  $R_L$  in parallel with the capacitive load, a voltage divider (proportional to  $R_{ISO}/R_L$ ) is formed, this will result in a gain error.

The circuit in Figure 2 is an improvement to the one in Figure 1.  $R_F$  provides the DC accuracy by feed-forward the  $V_{IN}$  to  $R_L$ .  $C_F$  and  $R_{ISO}$  serve to counteract the loss of phase margin by feeding the high frequency component of the output signal back to the amplifier's inverting input, thereby preserving the phase margin in the overall feedback loop. Capacitive drive can be increased by increasing the value of  $C_F$ . This in turn will slow down the pulse response.

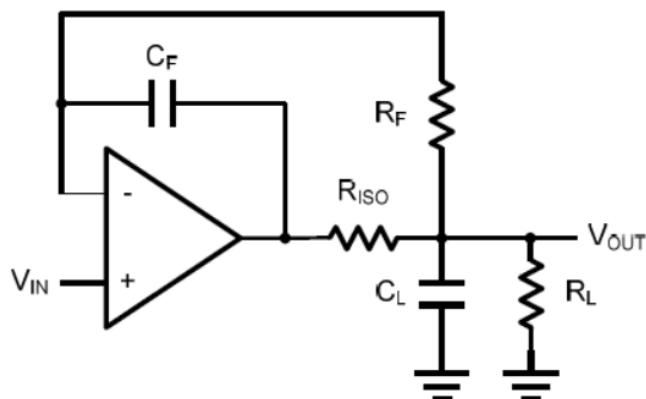

Figure 2. Indirectly Driving a Capacitive Load with DC Accuracy



## Typical Application Circuits

### Differential amplifier

The differential amplifier allows the subtraction of two input voltages or cancellation of a signal common the two inputs. It is useful as a computational amplifier in making a differential to single-end conversion or in rejecting a common mode signal. Figure 3. shown the differential amplifier using AO321.

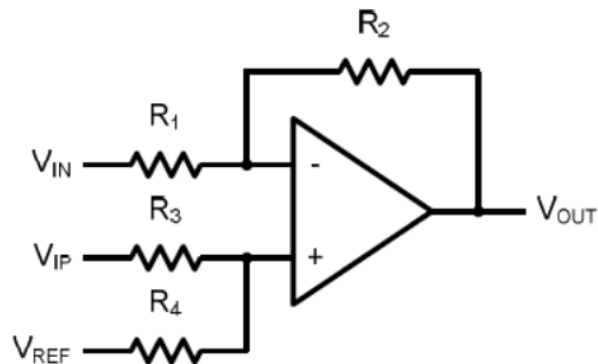

Figure 3. Differential Amplifier

$$V_{OUT} = \left( \frac{R_1 + R_2}{R_3 + R_4} \right) \frac{R_4}{R_1} V_{IN} - \frac{R_2}{R_1} V_{IP} + \left( \frac{R_1 + R_2}{R_3 + R_4} \right) \frac{R_3}{R_1} V_{REF}$$

If the resistor ratios are equal (i.e.  $R_1=R_3$  and  $R_2=R_4$ ), then

$$V_{OUT} = \frac{R_2}{R_1} (V_{IP} - V_{IN}) + V_{REF}$$

### Low Pass Active Filter

The low pass active filter is shown in Figure 4. The DC gain is defined by  $-R_2/R_1$ . The filter has a -20dB/decade roll-off after its corner frequency  $f_c=1/(2\pi R_3 C_1)$ .

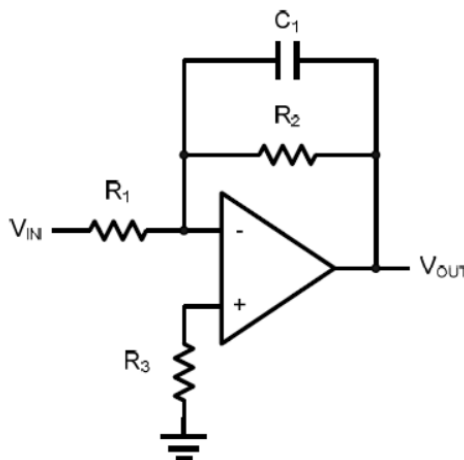

Figure 4. Low Pass Active Filter



### Instrumentation Amplifier

The triple AO321V can be used to build a three-op-amp instrumentation amplifier as shown in Figure 5. The amplifier in Figure 5 is a high input impedance differential amplifier with gain of  $R_2/R_1$ . The two differential voltage followers assure the high input impedance of the amplifier.

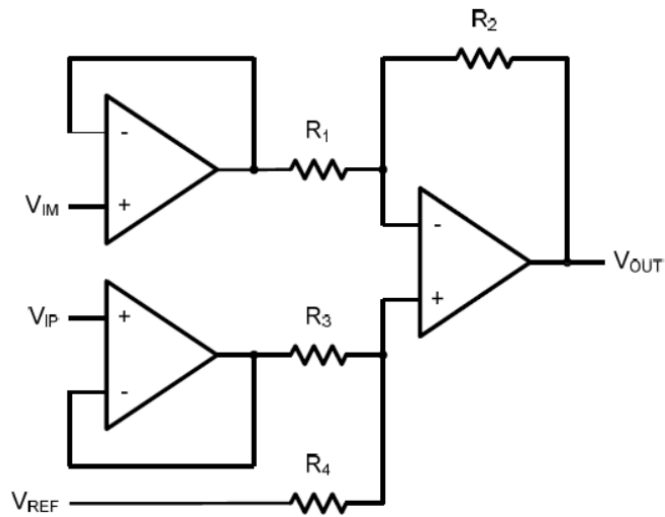
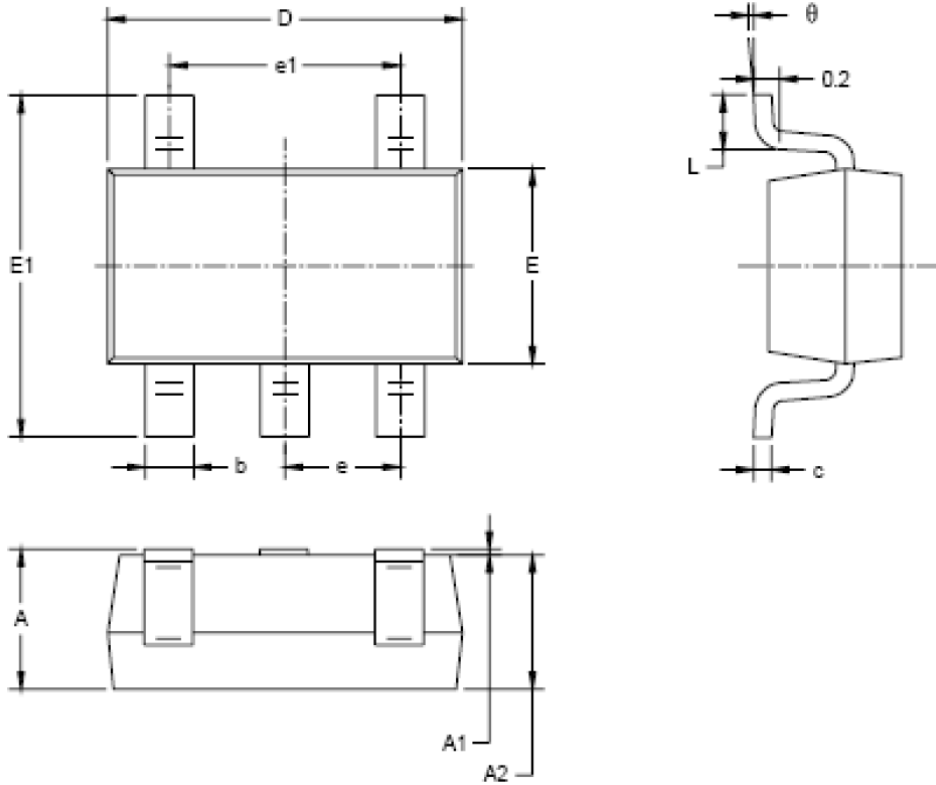

Figure 5. Instrument Amplifier



**PACKAGE INFORMATION**

Dimension in SOT-25 (Unit: mm)



Symbol	Millimeters		Inches	
	Min.	Max.	Min.	Max.
A	1.050	1.250	0.041	0.049
A1	0.000	0.100	0.000	0.004
A2	1.050	1.150	0.041	0.045
b	0.300	0.500	0.012	0.020
c	0.100	0.200	0.004	0.008
D	2.820	3.020	0.111	0.119
E	1.500	1.700	0.059	0.067
E1	2.650	2.950	0.104	0.116
e	0.950 BSC		0.037 BSC	
e1	1.900 BSC		0.075 BSC	
L	0.300	0.600	0.012	0.024
theta	0°	8°	0°	8°



## IMPORTANT NOTICE

AiT Semiconductor Inc. (AiT) reserves the right to make changes to any its product, specifications, to discontinue any integrated circuit product or service without notice, and advises its customers to obtain the latest version of relevant information to verify, before placing orders, that the information being relied on is current.

AiT Semiconductor Inc.'s integrated circuit products are not designed, intended, authorized, or warranted to be suitable for use in life support applications, devices or systems or other critical applications. Use of AiT products in such applications is understood to be fully at the risk of the customer. As used herein may involve potential risks of death, personal injury, or severe property, or environmental damage. In order to minimize risks associated with the customer's applications, the customer should provide adequate design and operating safeguards.

AiT Semiconductor Inc. assumes to no liability to customer product design or application support. AiT warrants the performance of its products of the specifications applicable at the time of sale.