



● FEATURE

1. Capable of handling the highest current(up to 5A) of any chip-type common mode filter
2. Noise is greatly suppressed.

● APPLICATION

1. Used for power line noise suppression for any electronic devices. Used to counter adapter/battery line noise for relatively large electronic devices such as notebook, stand-alone word processor, etc.



● ORDERING INFORMATION

<u>CMH0502F</u>	<u>-251</u>
PN	Impedance(Ω)

● SHAPE AND DIMENSION

CMH0502F

● SCHEMATICS AND LAND PATTERNS(mm)

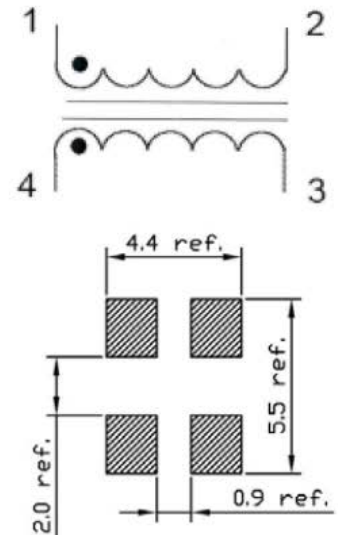
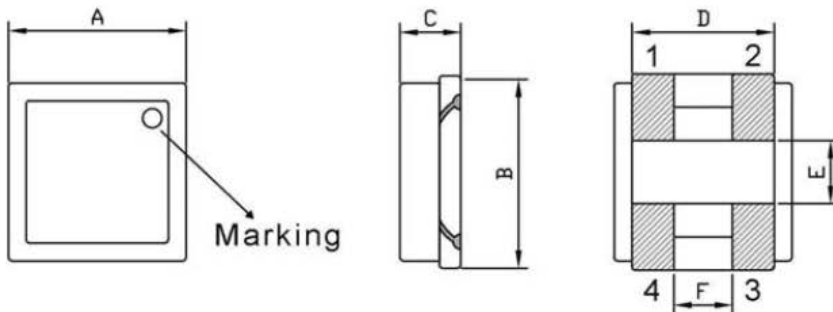

A=4.80±0.30 mm ; B=5.00±0.30 mm ; C=2.50 mm Max (do not include solder); D=3.50 mm Ref.
E=2.20 mm Ref. ; F=1.10 mm Ref.



CMH7060F

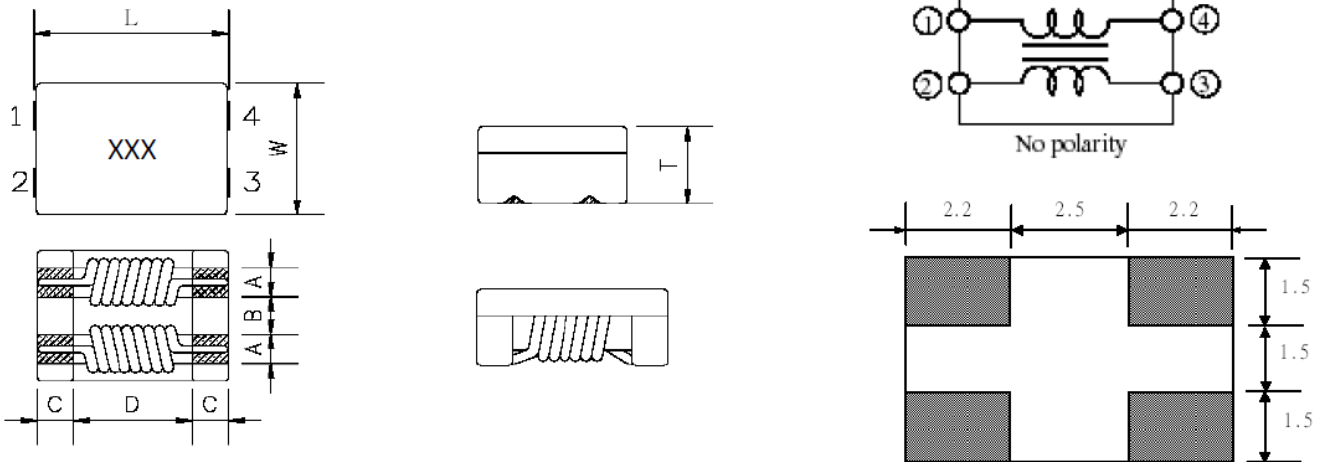

L=7.30±0.30 mm ; W=6.00±0.20 mm ; T=3.80 mm Max ; A=1.50 mm Ref. ; B=1.50 mm Ref.

C=1.70 mm Ref. ; D=3.50 mm Ref.

●ELECTRICAL CHARACTEISTICS

TYPE	Common mode Impedance Z(Ω) at 100MHz	DC Resistance (mΩ)	Rated Current(A)	Rated Voltage(V)	Insulation Resistance (MΩ)Min
	Typical				
CMH0502F-251	250	14±40%	5.0	50	10
CMH0502F-501	500	19±40%	4.0	50	10
CMH0502F-102	1000	24±40%	2.5	50	10
CMH0502F-142	1400	40±40%	2.0	50	10
CMH7060F-301	300	10Max	5.0	80	10
CMH7060F-701	700	15Max	4.0	80	10
CMH7060F-102	1000	17Max	3.0	80	10
CMH7060F-132	1300	21Max	2.5	80	10

Note1: Measurement ambient temperature of Impedance, DCR and IDC : at 25°C



●CHARACTERISTICS

1. CMH0502F-251

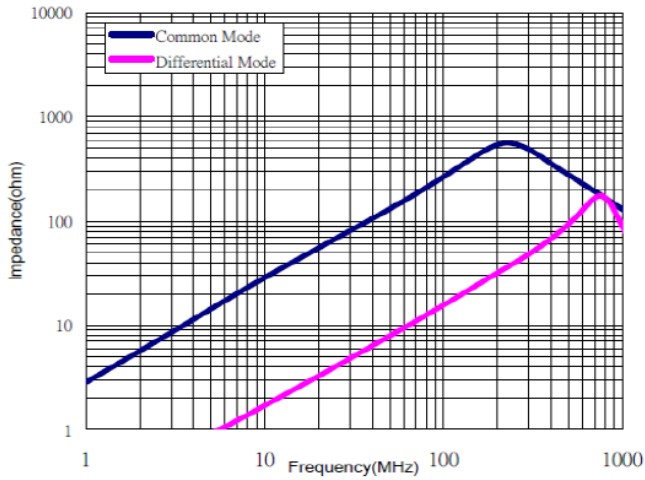

2. CMH0502F-501

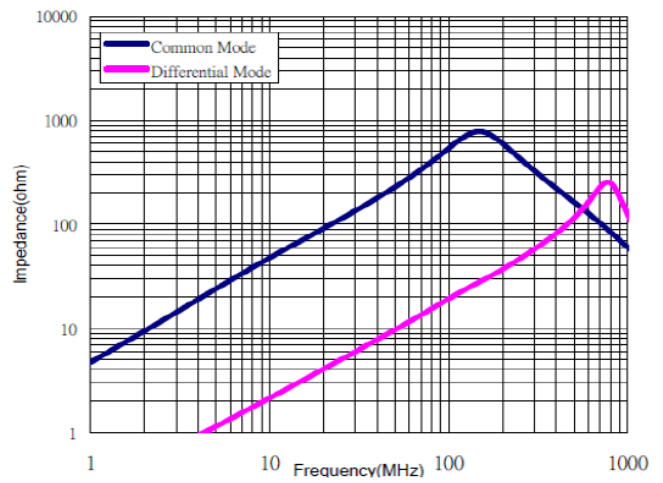

3. CMH0502F-102

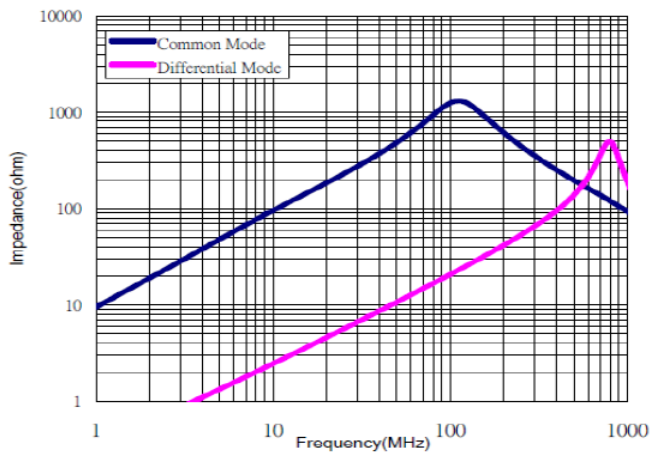

4. CMH0502F-142

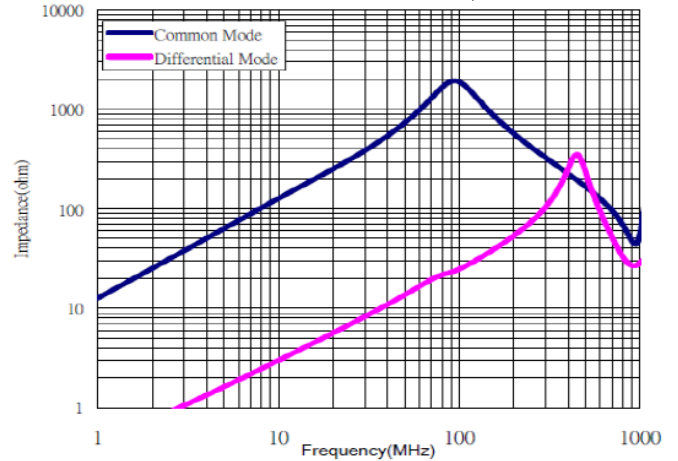

5. CMH7060F-301

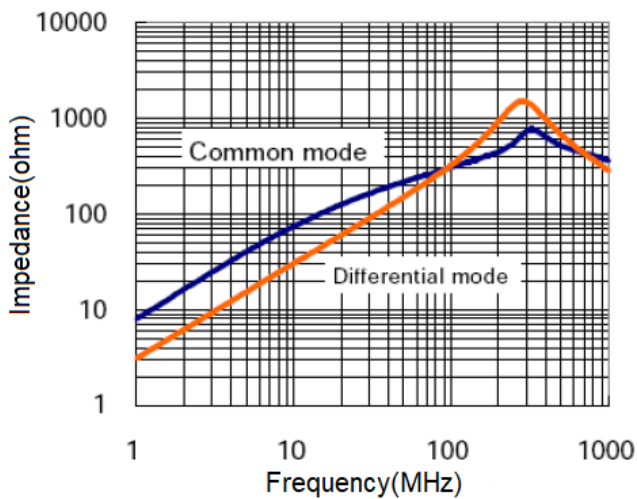

6. CM7H060F-701

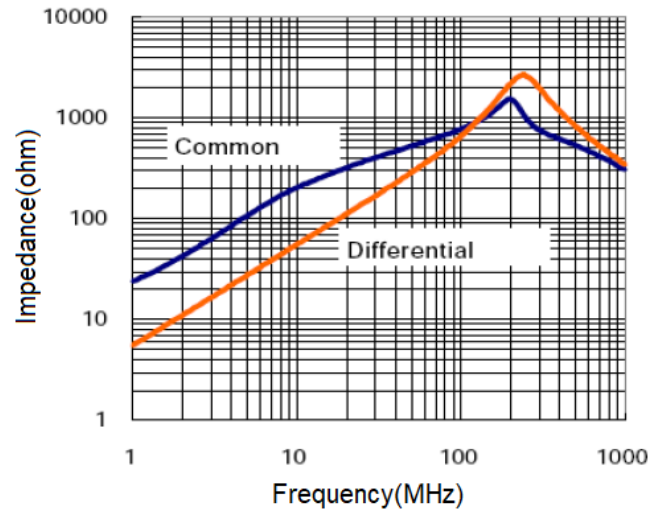



7. CMH7060F-102

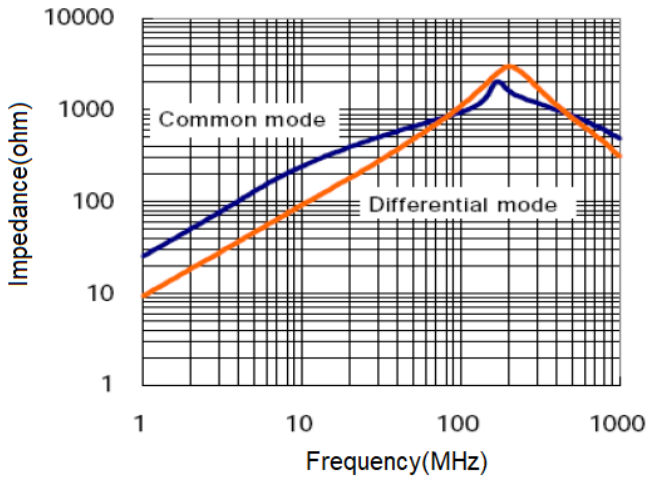



●GENERAL CHARACTERISTICS

1. Operating temperature range: -40 TO + 105°C (Includes temperature when the coil is heated)
2. External appearance: On visual inspection, the coil has no external defects.
3. Terminal strength: After soldering. Between copper plate and terminals of coil.
Push in two directions of X.Y withstanding at below conditions.
Terminal should not peel off. (refer to figure at right)
Applied force: 5N; Duration: 60sec.
4. Insulating resistance: Over 100MΩ at 100V D.C. between coil and core.
5. Dielectric strength: No dielectric breakdown at 100V D.C. for 1 minute between coil and core.
6. Temperature characteristics: Inductance coefficient $(0\sim 2,000)\times 10^{-6}/^{\circ}\text{C}$ (-25~+80°C degree Celsius)
Inductance deviation within±5.0%, after 96 hours
7. Humidity characteristics (Moisture Resistance): Inductance deviation within ±5%, after 96 hours in 90~95% relative humidity at 40 ±2°C and 1 hour drying under normal condition.
8. Vibration resistance: Inductance deviation within ±5%, after vibration for 1 hour. In each of three orientations at sweep vibration (10~55~10Hz) with 1.5mm P-P amplitudes.
9. Shock resistance: Inductance deviation within ±5%, after being dropped once with 981m/s² (100G) shock attitude upon a rubber block method shock testing machine, in three different orientations.
10. Resistance to Soldering Heat: 260°C, 10 seconds. (See attached recommend reflow)
11. Storage environment:
Storage condition: Temperature Range: 0°C ~ 35°C ; -40°C ~ 105°C (after PCB)
Humidity Range: 50% ~ 70% RH
12. Use components within 12 months. If 12 months or more have elapsed, check solderability before use.
Reflow profile recommend:

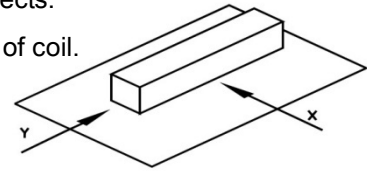

Lead - free heat endurance test

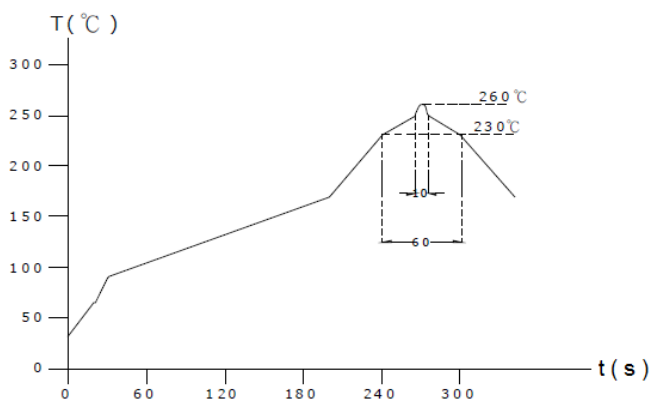

Lead-free the recommended reflow condition

