



DESCRIPTION

The AO1170 offers high voltage (36V), cost-optimized operation amplifier. AO1170 also offers strong general-purpose DC and AC specifications, including rail-to-rail output, low offset, low offset drift and 1.2MHz bandwidth.

Convenient features such as wide differential input voltage range, high output current, and high slew rate of 0.67V/us make the AO1170 a robust operational amplifier for high-voltage, cost-effective applications. as well as excellent speed/power consumption ratio, providing an excellent bandwidth (1.2MHz) and slew rate of 0.67V/us. The op-amps are unity gain stable and feature an ultra- low input bias current.

The AO1170 is stable at capacitance up to 100pF (Typ) and operation under single power supplies of 3V to 36V or dual power supplies of $\pm 1.5V$ to $\pm 18V$.

The AO1170 is available in SOT-25 package.

ORDERING INFORMATION

Package Type	Part Number	
SOT-25 SPQ: 3,000pcs/Reel	E5	AO1170E5R-Z
		AO1170E5VR-Z
Note	Z: Package Type see pin description V: Halogen free Package R: Tape & Reel	
AiT provides all RoHS products		

FEATURES

- Low Offset Voltage: $\pm 0.8mV$ (Typical)
- Low Offset Voltage Drift: $\pm 3\mu V/^{\circ}C$
- Low Noise: $45nV/\sqrt{Hz}$ at 1kHz
- High Common-Mode Rejection Ratio: 110dB
- Low Bias Current: $\pm 10pA$
- Rail-to-Rail Output
- Wide Bandwidth: 1.2MHz GBW
- High Slew Rate: 0.67V/us
- Low Quiescent Current: 150uA per Amplifier
- Supply Range: +3V to +36V
- Available in SOT-25 package

APPLICATION

- Merchant Network and Server PSU
- Industrial AC-DC & Merchant DC/DC
- Motor Drives: AC and Servo Drive Power Supplies
- Building Automation
- Sensors
- Photodiode Amplification
- Active Filters
- Test Equipment

TYPICAL APPLICATION

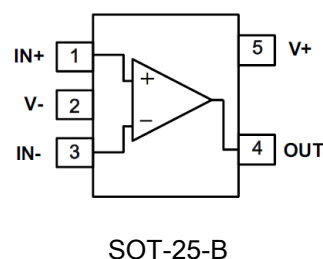
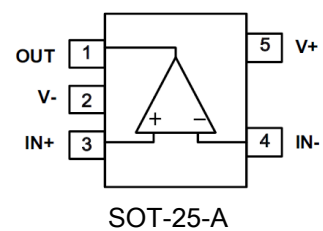



PIN DESCRIPTION

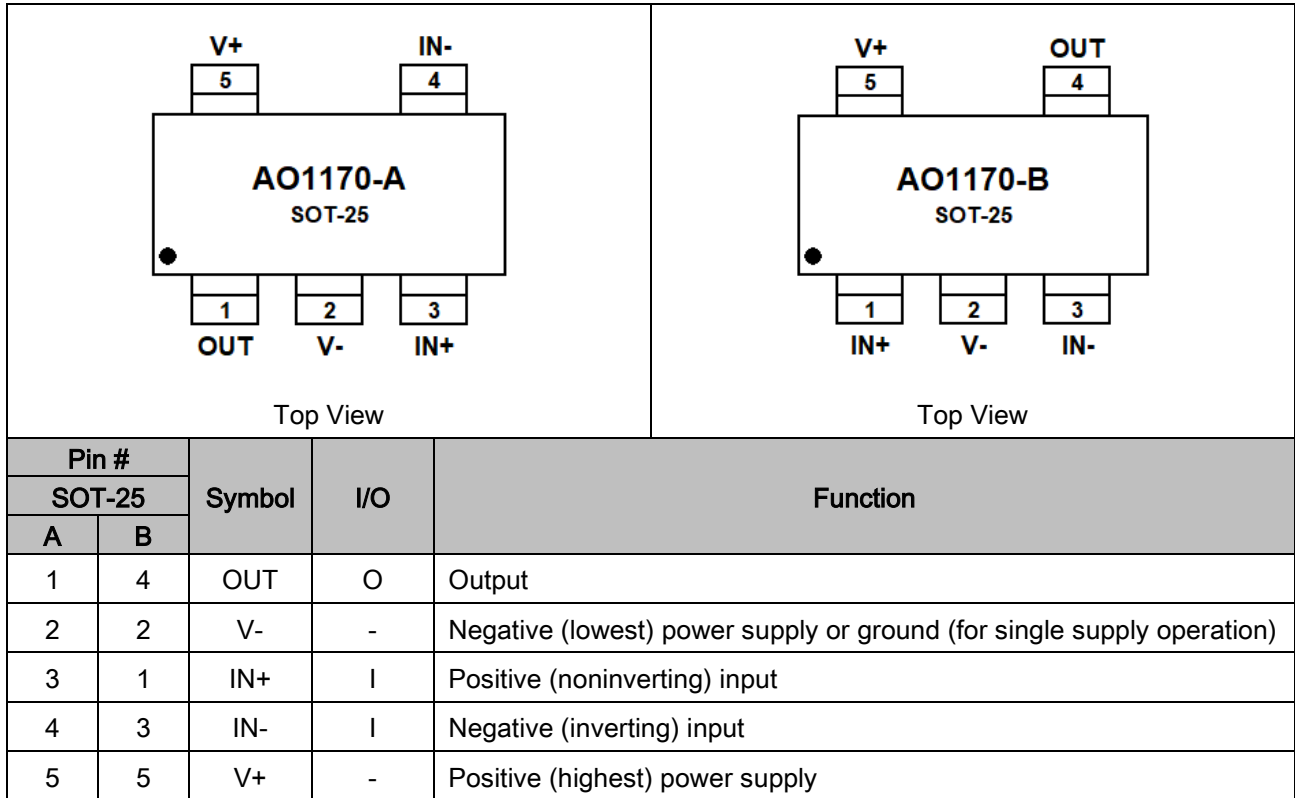



ABSOLUTE MAXIMUM RATINGS

over operating free-air temperature range, unless otherwise noted

Supply Voltage, $V_s=(V+) - (V-)$	-0.7V ~ 36V	
Signal Input Voltage P_{in}^{NOTE1}	(V-)-0.2V ~ (V+)0.2V	
Signal Output Voltage P_{in}^{NOTE2}	(V-)-0.2V ~ (V+)0.2V	
Signal Input Current P_{in}^{NOTE1}	-10mA ~ 10mA	
Signal Output Current P_{in}^{NOTE2}	-100mA ~ 100mA	
Output Short-Circuit Current NOTE3	Continuous	
T_A , Operating Range Temperature	-40°C ~ 125°C	
T_J , Junction Temperature	150°C	
T_{STG} , Storage Temperature	-55°C ~ 150°C	
ESD Ratings^{NOTE4}		
$V_{(ESD)}$, Electrostatic discharge	Human-body model (HBM)	±5000V
	Machine Model (MM)	±200V

Stress beyond above listed “Absolute Maximum Ratings” may lead permanent damage to the device. These are stress ratings only and operations of the device at these or any other conditions beyond those indicated in the operational sections of the specifications are not implied. Exposure to absolute maximum rating conditions for extended periods may affect device reliability.

NOTE1: Input terminals are diode-clamped to the power-supply rails. Input signals that can swing more than 0.5V beyond the supply rails should be current-limited to 10mA or less.

NOTE2: Output terminals are diode-clamped to the power-supply rails. Output signals that can swing more than 0.5V beyond the supply rails should be current-limited to ±100mA or less.

NOTE3: Short-circuit to ground, one amplifier per package.

NOTE4: JEDEC document JEP155 states that 500-V HBM allows safe manufacturing with a standard ESD control process.

RECOMMENDED OPERATING CONDITIONS

over operating free-air temperature range, unless otherwise noted

Parameter		Min.	Typ.	Max.	Unit
Supply voltage $V_s= (V+) - (V-)$	Single-Supply	3	-	36	V
	Dual-Supply	±1.5	-	±18	



ELECTRICAL CHARACTERISTICS

at $T_A = +25^\circ\text{C}$, $V_S = 3\text{V}$ to 36V , $R_L = 10\text{k}\Omega$ connected to $V_S/2$, and $V_{OUT} = V_S/2$, unless otherwise noted.

Parameter	Symbol	Conditions	T_J	Min	Typ	Max	Units
POWER SUPPLY							
Operating Voltage Range	V_S		$+25^\circ\text{C}$	3	-	36	V
Quiescent Current/Amplifier	I_Q	$V_S = \pm 2.5\text{V}$, $I_O = 0\text{mA}$	$+25^\circ\text{C}$	-	150	250	μA
		$V_S = \pm 18\text{V}$, $I_O = 0\text{mA}$		-	200	350	
Power-Supply Rejection Ratio	PSRR	$V_S = 5\text{V}$ to 36V	$+25^\circ\text{C}$	98	120	-	dB
INPUT							
Input Offset Voltage	V_{OS}	$V_{CM} = V_S/2$	$+25^\circ\text{C}$	-4	± 0.8	4	mV
			-40°C to 125°C	-	± 1.1		
Input Offset Voltage Average Drift	V_{OS} Tc		-40°C to 125°C	-	3	-	$\mu\text{V}/^\circ\text{C}$
Input Bias Current	I_B	$V_{CM} = 0\text{V}$	$+25^\circ\text{C}$	-	10	60	pA
			-40°C to 125°C	-	600	-	
Input Offset Current	I_{OS}	$V_{CM} = 0\text{V}$	$+25^\circ\text{C}$	-	10	60	pA
			-40°C to 125°C	-	600	-	
Common-Mode Voltage Range	V_{CM}	$V_S = \pm 18\text{V}$	$+25^\circ\text{C}$	(V-)-0.1	-	(V+)-2	V
Common-Mode Rejection Ratio	CMRR	$V_S = \pm 2.5\text{V}$, $V_{CM} = (\text{V-}) - 0.1\text{V}$ to $(\text{V+}) - 2\text{V}$	$+25^\circ\text{C}$	70	110	-	dB
		$V_S = \pm 18\text{V}$, $V_{CM} = (\text{V-}) - 0.1\text{V}$ to $(\text{V+}) - 2\text{V}$	$+25^\circ\text{C}$	70	-	-	
OUTPUT							
Open-Loop Voltage Gain	A_{OL}	$R_L = 10\text{k}\Omega$, $V_O = (\text{V-}) - 0.6\text{V}$ to $(\text{V+}) - 0.6\text{V}$	$+25^\circ\text{C}$	93	115	-	dB
Output Swing	V_{OH}	$V_S = \pm 18\text{V}$, $R_L = 10\text{k}\Omega$	$+25^\circ\text{C}$	17.85	-	-	V
	V_{OL}			-	-	-17.85	V
Short-Circuit Current	I_{SC}	$V_S = 36\text{V}$, $V_O = 0\text{V}$	$+25^\circ\text{C}$	-	70	-	mA
Capacitive Load Drive	C_{LOAD}		$+25^\circ\text{C}$	-	100	-	pF
FREQUENCY RESPONSE							
Slew Rate	SR	$G = +1$, $C_L = 100\text{pF}$	$+25^\circ\text{C}$	-	0.67	-	V/ μs
Gain-Bandwidth Product	GBW		$+25^\circ\text{C}$	-	1.2	-	MHz
Setting Time, 0.01%	t_s	$V_S = \pm 2.5\text{V}$, $G = +1$, $C_L = 100\text{pF}$, Step=2V	$+25^\circ\text{C}$	-	5	-	μs
Overload Recovery Time	t_{OR}	$V_{IN} \cdot \text{Gain} \geq V_S$, $G = 11$	$+25^\circ\text{C}$	-	5	-	μs
Turn On Time	t_{ON}		$+25^\circ\text{C}$	-	10	-	μs
NOISE							
Input Voltage Noise	E_n	$f = 0.1\text{Hz}$ to 10Hz , $V_S = \pm 2.5\text{V}$	$+25^\circ\text{C}$	-	16	-	μV_{pp}
Input Voltage Noise Density	e_n	$f = 1\text{KHz}$	$+25^\circ\text{C}$	-	45	-	$\text{nV}/\sqrt{\text{Hz}}$



TYPICAL PERFORMANCE CHARACTERISTICS

at $T_A = +25^\circ\text{C}$, $V_S = \pm 18\text{V}$, $R_L = 10\text{k}\Omega$ connected to $V_S/2$, $V_{OUT} = V_S/2$, unless otherwise noted.

1. Open-Loop Gain and Phase vs. Frequency

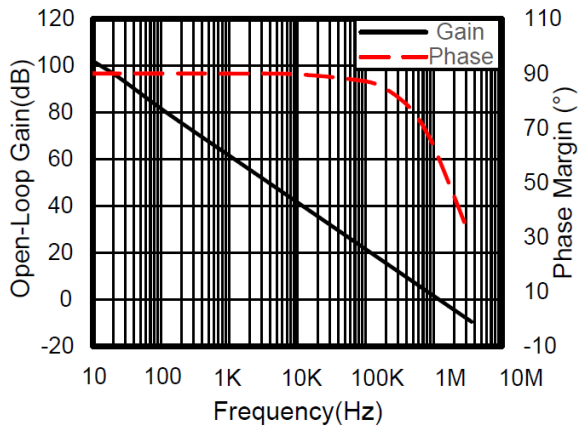

2. Large Signal Step Response

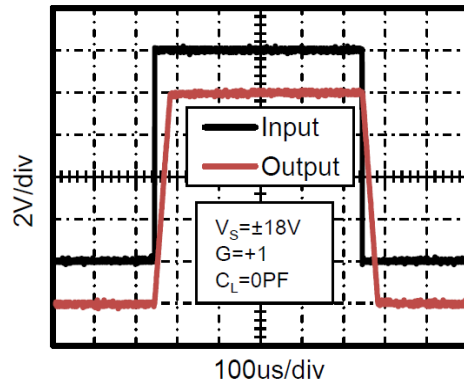

3. Large Signal Step Response

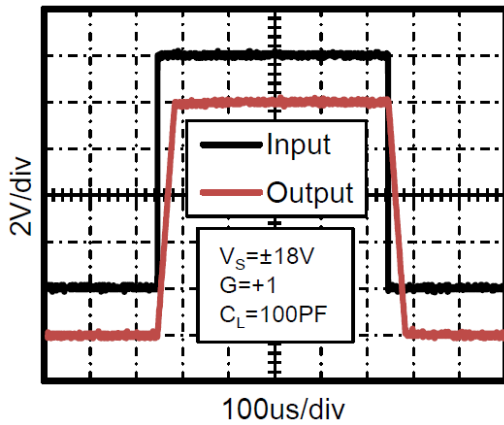

4. Small Signal Step Response

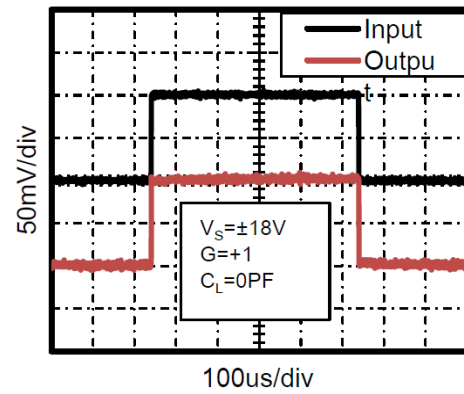

5. Small Signal Step Response

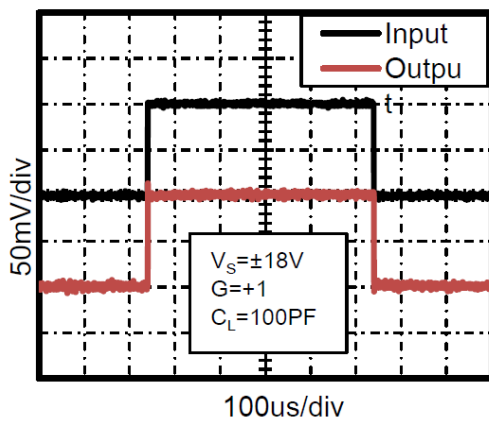

6. Positive Overvoltage Recovery

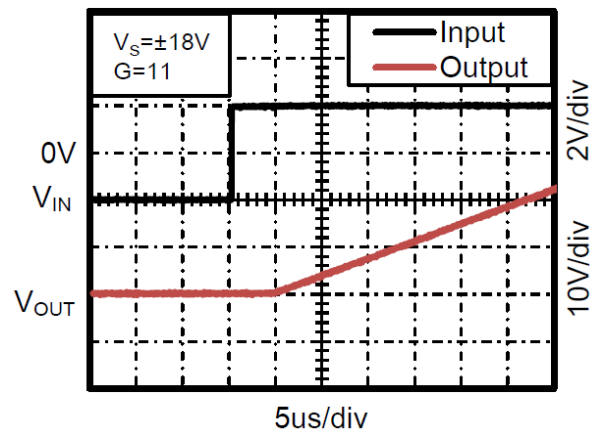



7. Negative Overvoltage Recovery

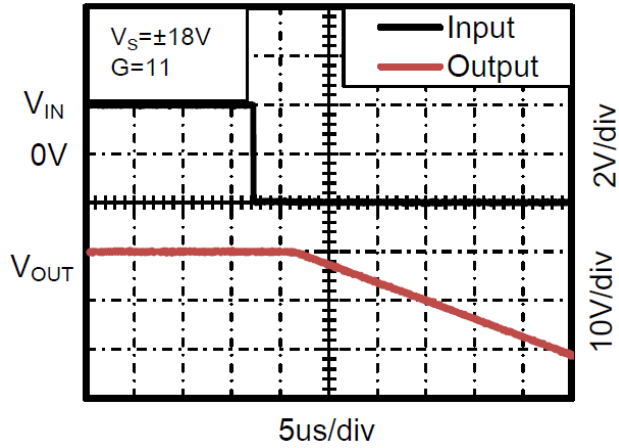

8. Output Voltage Swing vs Output Current

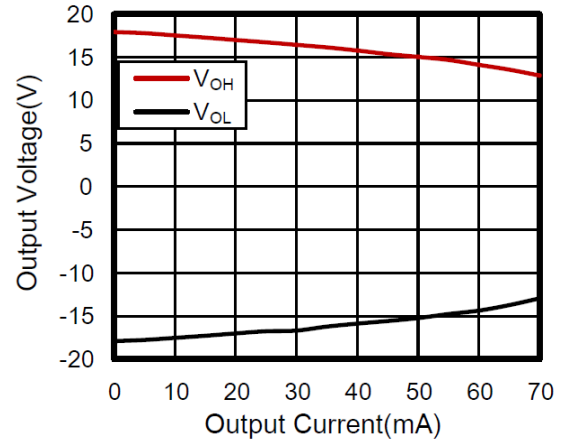

9. 0.1Hz to 10Hz Noise at $V_S = 5V$

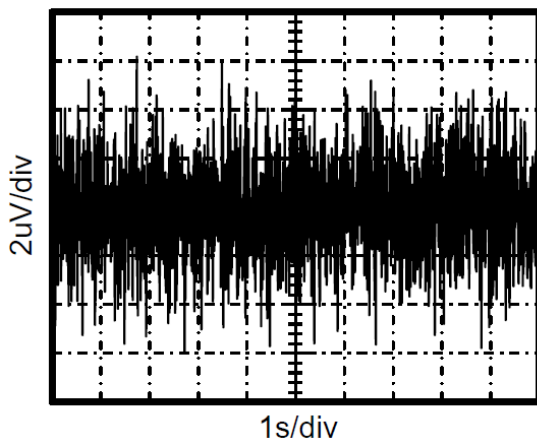



PACKAGE INFORMATION

Dimension in SOT-25 (Unit: mm)

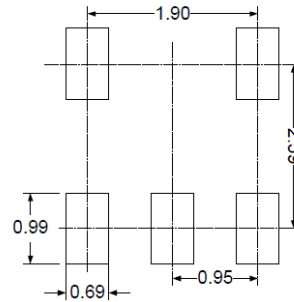
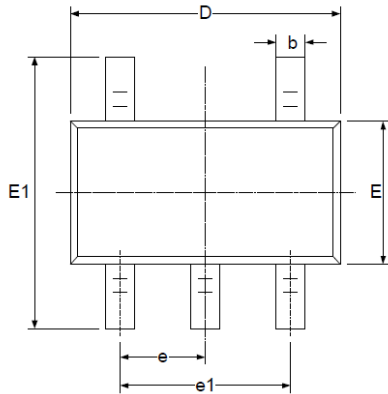

RECOMMENDED LAND PATTERN (Unit: mm)

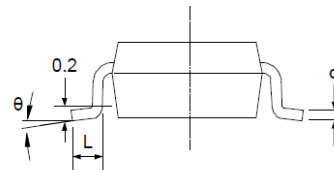
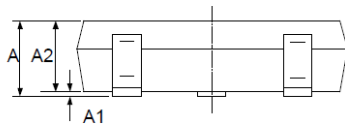

Symbol	Millimeters		Inches	
	Min	Max	Min	Max
A	1.050	1.250	0.041	0.049
A1	0.000	0.100	0.000	0.004
A2	1.050	1.150	0.041	0.045
b	0.300	0.500	0.012	0.020
c	0.100	0.200	0.004	0.008
D	2.820	3.020	0.111	0.119
E	1.500	1.700	0.059	0.067
E1	2.650	2.950	0.104	0.116
e	0.950 BSC		0.037 BSC	
e1	1.800	2.000	0.071	0.079
L	0.300	0.600	0.012	0.024
θ	0°	8°	0°	8°



IMPORTANT NOTICE

AiT Semiconductor Inc. (AiT) reserves the right to make changes to any its product, specifications, to discontinue any integrated circuit product or service without notice, and advises its customers to obtain the latest version of relevant information to verify, before placing orders, that the information being relied on is current.

AiT Semiconductor Inc.'s integrated circuit products are not designed, intended, authorized, or warranted to be suitable for use in life support applications, devices or systems or other critical applications. Use of AiT products in such applications is understood to be fully at the risk of the customer. As used herein may involve potential risks of death, personal injury, or severe property, or environmental damage. In order to minimize risks associated with the customer's applications, the customer should provide adequate design and operating safeguards.

AiT Semiconductor Inc. assumes to no liability to customer product design or application support. AiT warrants the performance of its products of the specifications applicable at the time of sale.