



DESCRIPTION

The MM3Z2V0 ~ MM3Z75V are available in SOD-323 package.

ORDERING INFORMATION

Package Type	Part Number
SOD-323	MM3Z2V0
	MM3Z2V2
	MM3Z2V4
	MM3Z2V7
	MM3Z3V0
	MM3Z3V3
	MM3Z3V6
	MM3Z3V9
	MM3Z4V3
	MM3Z4V7
	MM3Z5V1
	MM3Z5V6
	MM3Z6V2
	MM3Z6V8
	MM3Z7V5
	MM3Z8V2
	MM3Z9V1
	MM3Z10V
	MM3Z11V
	MM3Z12V
	MM3Z13V
	MM3Z15V
	MM3Z16V
	MM3Z18V
	MM3Z20V
	MM3Z22V
	MM3Z24V
	MM3Z27V
	MM3Z30V
	MM3Z33V
	MM3Z36V
	MM3Z39V
	MM3Z43V
MM3Z47V	
MM3Z51V	
MM3Z56V	
MM3Z62V	
MM3Z68V	
MM3Z75V	
Note	SPQ: 3,000pcs/Reel
AiT provides all RoHS Compliant Products	

FEATURES

- Total power dissipation: Max. 200mW.
- Wide zener reverse voltage range 2.0V to 75V.
- Small plastic package suitable for surface mounted design.
- Available in SOD-323 package

MECHANICAL DATA

Case: SOD-323

Terminals: Solderable per MIL-STD-750,
Method 2026

Tolerance approximately ±5%

Approx. Weight: 5.48mg / 0.00019oz

PIN DESCRIPTION

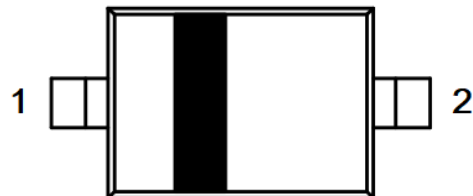

PIN	DESCRIPTION
1	Cathode
2	Anode





ABSOLUTE MAXIMUM RATINGS

T_A = 25°C, unless otherwise noted.

P _{tot} , Power Dissipation	200mW
V _F , Forward Voltage at I _F = 10mA	0.9V
R _{θJA} , Typical Thermal Resistance Junction to Ambient ^{NOTE1}	417°C/W
T _J , T _{STG} , Operating and Storage Temperature Range	-55°C ~ +150°C

Stresses above may cause permanent damage to the device. These are stress ratings only and functional operation of the device at these or any other conditions beyond those indicated in the Electrical Characteristics are not implied. Exposure to absolute maximum rating conditions for extended periods may affect device reliability.

ELECTRICAL CHARACTERISTICS

T_A = 25°C

Part Number	Zener Voltage Range ^{NOTE2}			Zener Impedance	Dynamic Impedance	Reverse Current	
	V _{ZT} (at I _{ZT})			I _{ZT}	Z _{ZT} (at I _{ZT})	I _R	at V _R
	Min (V)	Nom (V)	Max (V)	(mA)	Max (Ω)	Max (μA)	(V)
MM3Z2V0	1.8	2	2.15	5	100	120	0.5
MM3Z2V2	2.08	2.2	2.33	5	100	120	0.7
MM3Z2V4	2.28	2.4	2.56	5	100	120	1
MM3Z2V7	2.5	2.7	2.9	5	110	120	1
MM3Z3V0	2.8	3	3.2	5	120	50	1
MM3Z3V3	3.1	3.3	3.5	5	130	20	1
MM3Z3V6	3.4	3.6	3.8	5	130	10	1
MM3Z3V9	3.7	3.9	4.1	5	130	5	1
MM3Z4V3	4	4.3	4.6	5	130	5	1
MM3Z4V7	4.4	4.7	5	5	130	2	1
MM3Z5V1	4.8	5.1	5.4	5	130	2	1.5
MM3Z5V6	5.2	5.6	6	5	80	1	2.5
MM3Z6V2	5.8	6.2	6.6	5	50	1	3
MM3Z6V8	6.4	6.8	7.2	5	30	0.5	3.5
MM3Z7V5	7	7.5	7.9	5	30	0.5	4
MM3Z8V2	7.7	8.2	8.7	5	30	0.5	5
MM3Z9V1	8.5	9.1	9.6	5	30	0.5	6
MM3Z10V	9.4	10	10.6	5	30	0.1	7
MM3Z11V	10.4	11	11.6	5	30	0.1	8
MM3Z12V	11.4	12	12.7	5	35	0.1	9



Part Number	Zener Voltage Range ^{NOTE1}			Zener Impedance	Dynamic Impedance	Reverse Current	
	V _{ZT} (at I _{ZT})			I _{ZT}	Z _{ZT} (at I _{ZT})	I _R	at V _R
	Min (V)	Nom (V)	Max (V)	(mA)	Max (Ω)	Max (μA)	(V)
MM3Z13V	12.4	13	14.1	5	35	0.1	10
MM3Z15V	13.8	15	15.6	5	40	0.1	11
MM3Z16V	15.3	16	17.1	5	40	0.1	12
MM3Z18V	16.8	18	19.1	5	45	0.1	13
MM3Z20V	18.8	20	21.2	5	50	0.1	15
MM3Z22V	20.8	22	23.3	5	55	0.1	17
MM3Z24V	22.8	24	25.6	5	60	0.1	19
MM3Z27V	25.1	27	28.9	2	70	0.1	21
MM3Z30V	28	30	32	2	80	0.1	23
MM3Z33V	31	33	35	2	80	0.1	25
MM3Z36V	34	36	38	2	90	0.1	27
MM3Z39V	37	39	41	2	100	0.1	30
MM3Z43V	40	43	46	2	130	0.1	33
MM3Z47V	44	47	50	2	150	0.1	36
MM3Z51V	48	51	54	2	180	0.1	39
MM3Z56V	52	56	60	2	200	0.1	43
MM3Z62V	58	62	66	2	215	0.1	47
MM3Z68V	64	68	72	2	240	0.1	52
MM3Z75V	70	75	79	2	265	0.1	56

NOTE1: Thermal resistance from junction to ambient at P.C.B. mounted with 2.0" X 2.0" (54 X 5 cm) copper areas pads.

NOTE2: V_{ZT} is tested with pulses (20ms)

1 TYPICAL PERFORMANCE CHARACTERISTICS

Figure 1. Maximum Continuous Power Derating

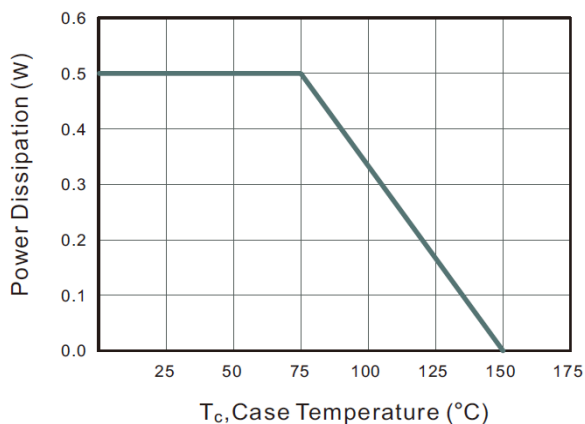
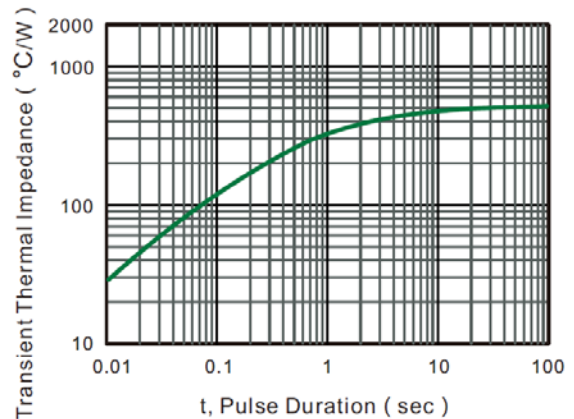

Figure 2. Typical Transient Thermal Impedance





PACKAGE INFORMATION

Dimension in SOD-323 Package (Unit: mm)

Plastic surface mounted package; 2 leads

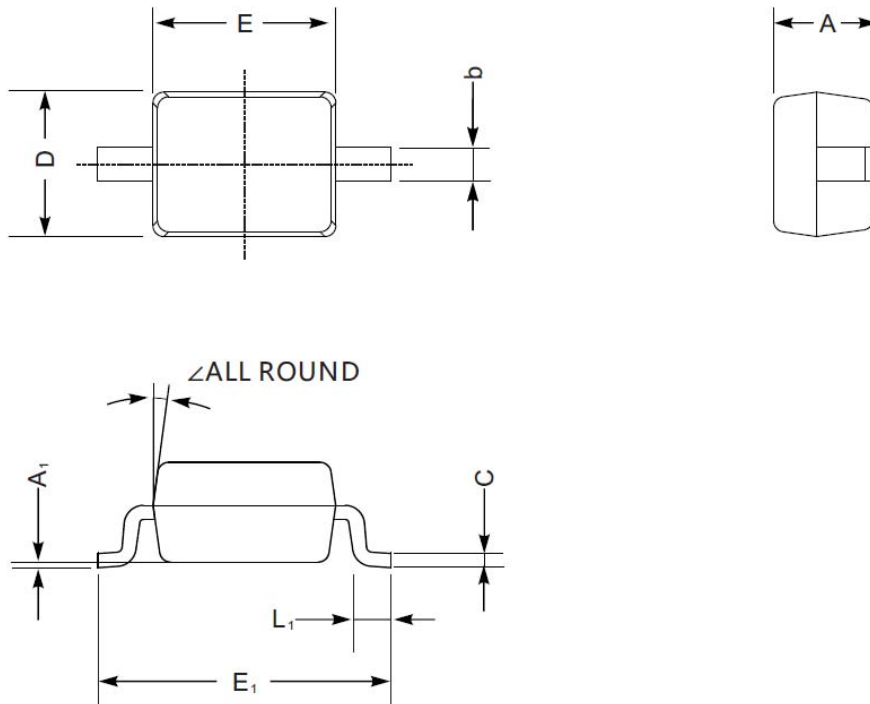

The recommended mounting pad size

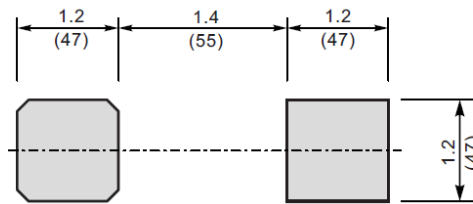

Unit: $\frac{\text{mm}}{(\text{mil})}$

UNIT		A	C	D	E	E ₁	B	L ₁	A ₁	∠
mm	Max	1.1	0.15	1.4	1.8	2.75	0.4	0.45	0.2	9°
	Min	0.8	0.08	1.2	1.4	2.55	0.25	0.2	-	
mil	Max	43	5.9	55	70	108	16	16	8	
	Min	32	3.1	47	63	100	9.8	7.9	-	



IMPORTANT NOTICE

AiT Semiconductor Inc. (AiT) reserves the right to make changes to any its product, specifications, to discontinue any integrated circuit product or service without notice, and advises its customers to obtain the latest version of relevant information to verify, before placing orders, that the information being relied on is current.

AiT Semiconductor Inc.'s integrated circuit products are not designed, intended, authorized, or warranted to be suitable for use in life support applications, devices or systems or other critical applications. Use of AiT products in such applications is understood to be fully at the risk of the customer. As used herein may involve potential risks of death, personal injury, or severe property, or environmental damage. In order to minimize risks associated with the customer's applications, the customer should provide adequate design and operating safeguards.

AiT Semiconductor Inc. assumes to no liability to customer product design or application support. AiT warrants the performance of its products of the specifications applicable at the time of sale.