



### DESCRIPTION

The A7632 is a constant frequency, current mode step-up converter intended for small, low power applications.

The A7632 switches at 1.2MHz and allows the use of tiny, low cost capacitors and inductors 2mm or less in height. Internal soft-start results in small inrush current and extends battery life.

The A7632 includes under-voltage lockout, current limiting, and thermal overload protection to prevent damage in the event of an output overload.

The A7632 is available in SOT-26 package.

### FEATURES

- 2.5V to 24V Input Voltage
- Up to 28V Output Voltage
- Accurate reference: 0.6V
- Integrated 80mΩ power MOSFET
- 1.2MHz switching frequency
- Internal 3A switch current Limit
- Internal compensation
- Thermal shutdown
- Available in SOT-26 Package

### APPLICATION

- ABS Set-Top Boxed
- DVB-S/S2

### ORDERING INFORMATION

Package Type	Part Number	
SOT-26 SPQ: 3,000pcs/Reel	E6	A7632E6R
		A7632E6VR
Note	V: Halogen free Package R: Tape & Reel	
AiT provides all RoHS products		

### External Inductor & Diodes

AiT Semiconductor

Inductor: WSI04020E-4R7M

Diode: SM140A

### TYPICAL APPLICATION

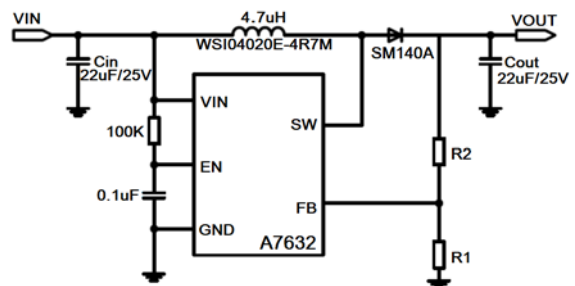

A7632 + WSI04020E-4R7M + SM140A

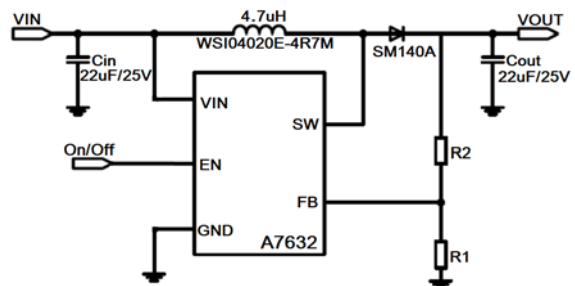

A7632 + WSI04020E-4R7M + SM140A



**PIN DESCRIPTION**

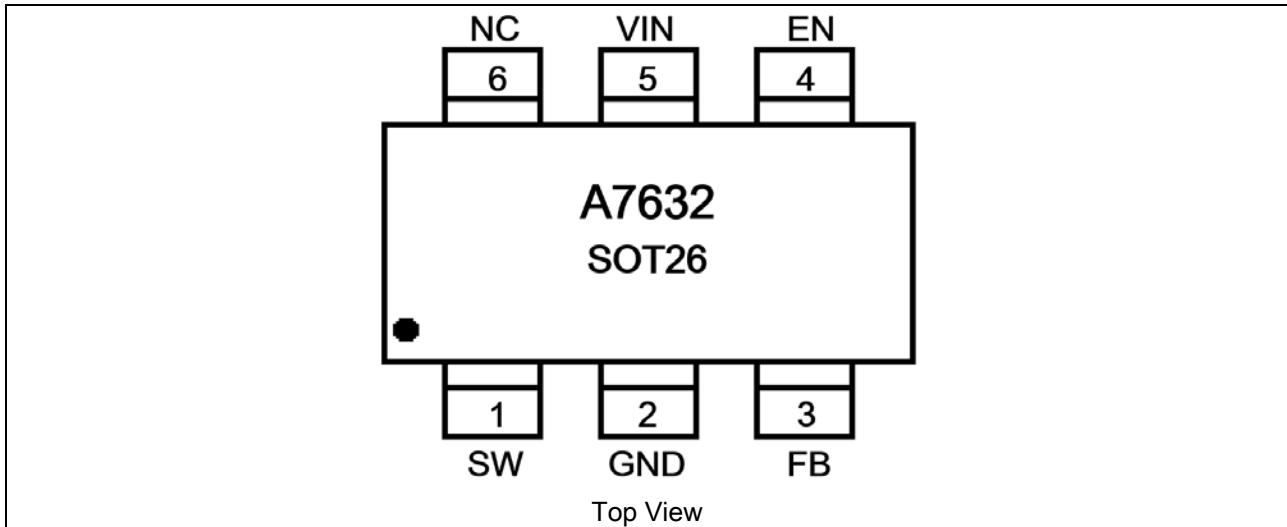

Pin #	Symbol	Function
1	SW	Power Switch Output. SW is the drain of the internal MOSFET switch. Connect the power inductor and output rectifier to SW. SW can swing between GND and 28V.
2	GND	Ground.
3	FB	Feedback input. The FB voltage is 0.6V. Connect a resistor divider to FB.
4	EN	Regulator On/Off control input. A high input at EN turns on the converter, and a low input turns it off. When not used, connect EN to the input supply for automatic startup.
5	VIN	Power supply. Must be locally bypassed.
6	NC	No connection

**ABSOLUTE MAXIMUM RATINGS**T<sub>A</sub> = 25°C

Parameter	Symbol	Value	Unit	
IN, EN Pin Voltage		-0.3 ~ 26	V	
SW Pin Voltage		-0.3 ~ 26	V	
All Other Pin Voltage		-0.3 ~ 6	V	
Junction Temperature	T <sub>J</sub>	150	°C	
Ambient Temperature	T <sub>A</sub>	-40 ~ 85	°C	
Power Dissipation	SOT-26	600	mW	
Thermal Resistance		θ <sub>JA</sub>	250	°C/W
Thermal Resistance		θ <sub>JC</sub>	130	°C/W
Storage Temperature	T <sub>S</sub>	-65 ~ 150	°C	
Lead Temperature & Time		260, 10	°C,Sec	

Stress beyond above listed "Absolute Maximum Ratings" may lead permanent damage to the device. These are stress ratings only and operations of the device at these or any other conditions beyond those indicated in the operational sections of the specifications are not implied. Exposure to absolute maximum rating conditions for extended periods may affect device reliability.

**RECOMMENDED OPERATING CONDITIONS**

Parameter	Symbol	Value	Units
Input Voltage Range		2.5 to 24	V
Output Voltage Range		V <sub>IN</sub> to 28	V
Operating Junction Temperature	T <sub>J</sub>	-40 to 125	°C

**ELECTRICAL CHARACTERISTICS**Test Conditions:  $V_{IN}=5V$  and  $V_{OUT}=12V$ ,  $L= WSI4020E-4R7M = 4.7\mu H$ .  $T_A=25^\circ C$ , unless otherwise noted

Parameter	Symbol	Conditions	Min.	Typ.	Max.	Unit
Operating Input Voltage	$V_{IN}$		2.5	-	24	V
Under voltage lockout threshold	$V_{IN\_UVLO}$	$V_{IN}$ rising	-	2.4	-	V
		$V_{IN\_UVLO}$ hysteresis	-	50	-	mV
Feedback Voltage	$V_{FB}$		588	600	612	mV
FB Input Bias Current	$I_{FB}$	$V_{FB}=0.6V$	-50	-10	-	nA
SW Leakage	$I_{SW\_LKG}$	$V_{SW}=20V$	-	-	1	$\mu A$
Quiescent Current	$I_Q$	$V_{FB}=0.8V$ , No Switch	-	0.25	0.5	mA
		$V_{EN}=0V$	-	0.1	1	$\mu A$
Oscillator Frequency	$F_{SW}$		-	1.2	-	MHz
Soft-start time	$T_{SS}$			1.5		mS
Maximum Duty Cycle	$D_{MAX}$		-	85	-	%
Minimum ON time	$T_{ON(MIN)}$		-	120	-	ns
EN pin logic high threshold	$V_{EN\_H}$		1.0	-	-	V
EN pin logic low threshold	$V_{EN\_L}$		-	-	0.5	V
SW On-Resistance	$R_{DS\_ON}$		-	200	-	m $\Omega$
Current Limit	$I_{LIMIT}$	$V_{IN}=5V$ , Duty Cycle = 50%	-	3	-	A
Thermal Shutdown	$T_{SD}$		-	160	-	$^\circ C$



## TYPICAL PERFORMANCE CHARACTERISTICS

1. Efficiency vs. I<sub>out</sub> (V<sub>OUT</sub>=5V)

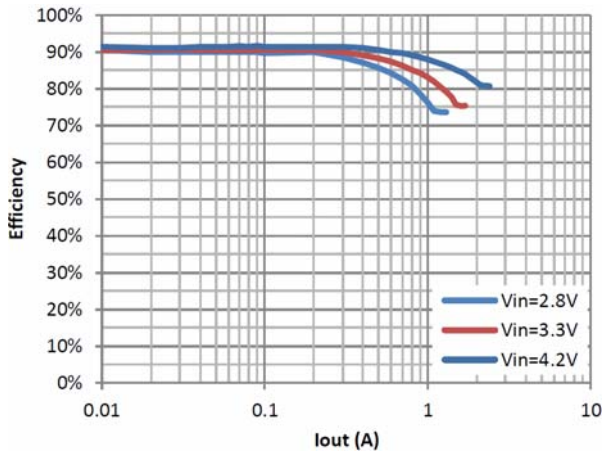

2. Efficiency vs. I<sub>out</sub> (V<sub>OUT</sub>=9V)

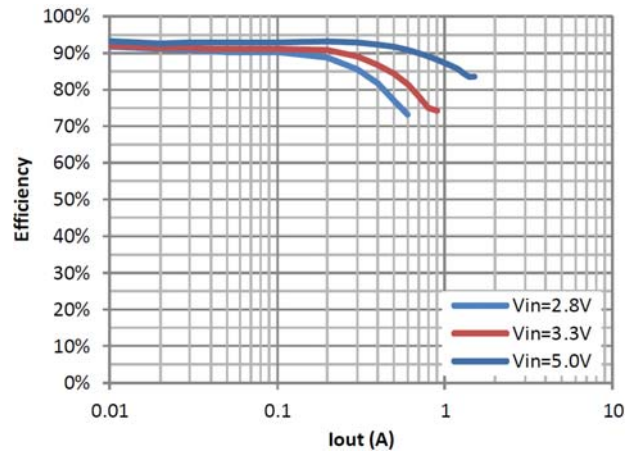

3. Efficiency vs. I<sub>out</sub> (V<sub>OUT</sub>=12V)

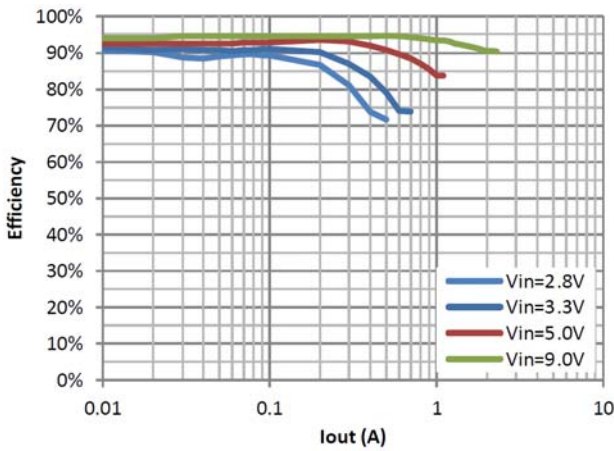

4. Efficiency vs. I<sub>out</sub> (V<sub>OUT</sub>=18V)

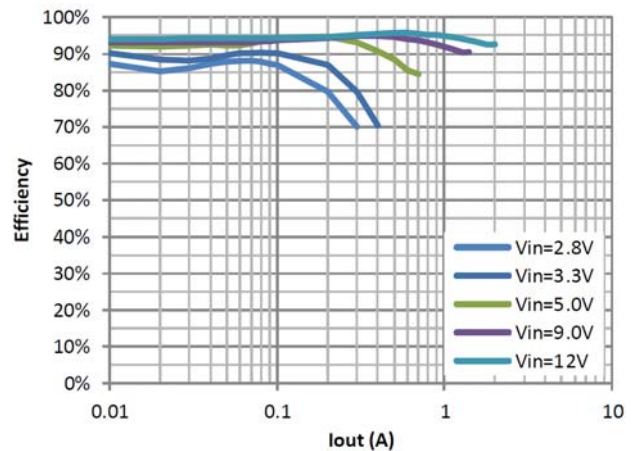

5. Efficiency vs. I<sub>out</sub> (V<sub>OUT</sub>=24V)

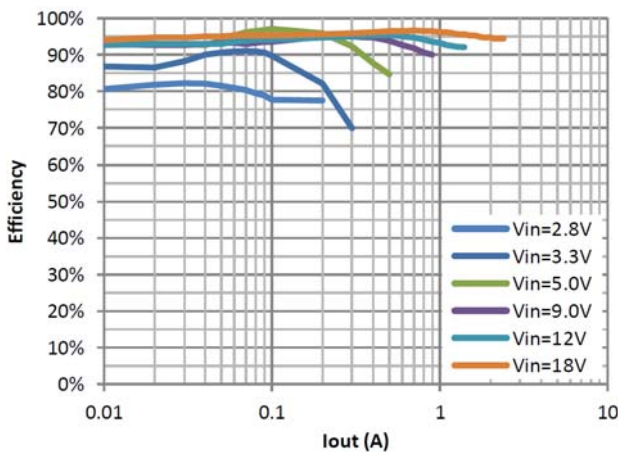

6. Efficiency vs. I<sub>out</sub> (V<sub>OUT</sub>=28V)

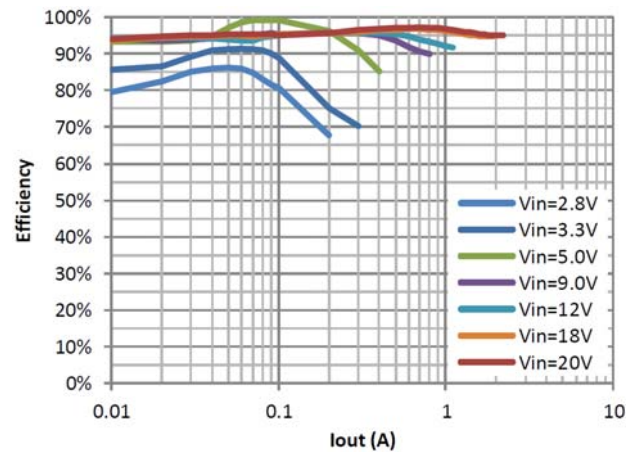



7. Load Regulation ( $V_{OUT}=5V$ )

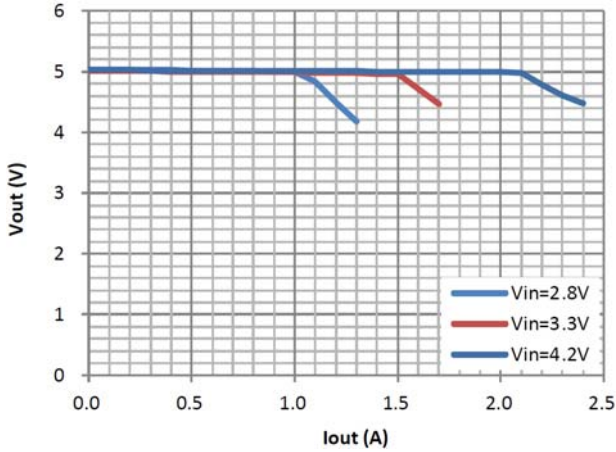

8. Load Regulation ( $V_{OUT}=9V$ )

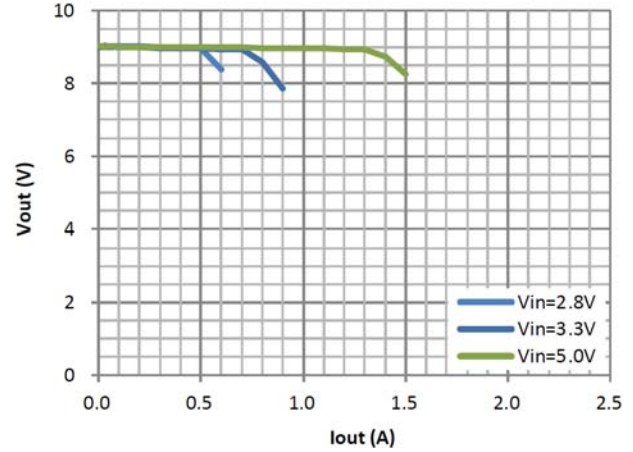

9. Load Regulation ( $V_{OUT}=12V$ )

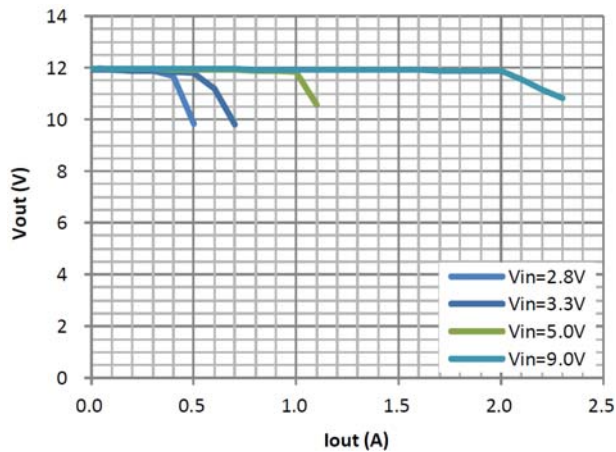

10. Load Regulation ( $V_{OUT}=18V$ )

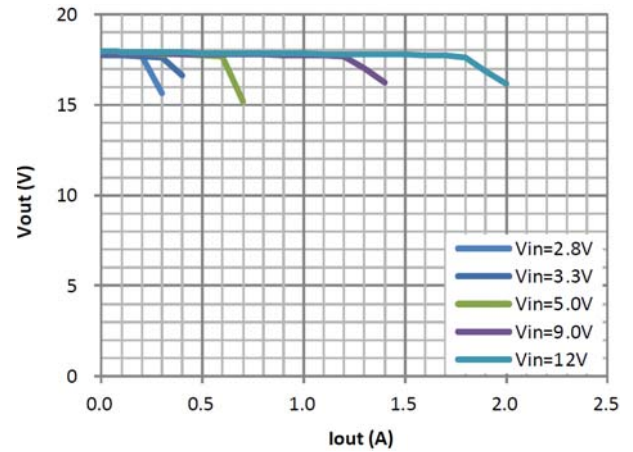

11. Load Regulation ( $V_{OUT}=24V$ )

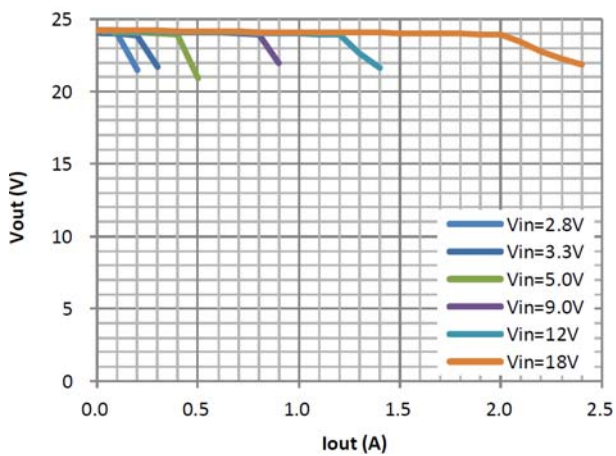

12. Load Regulation ( $V_{OUT}=28V$ )

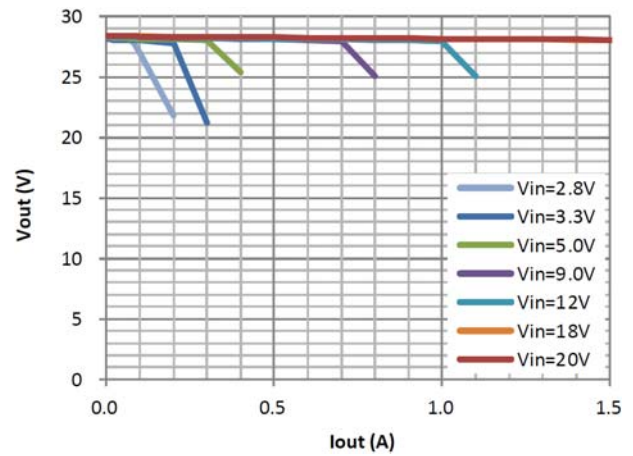



13.  $V_{FB}$  vs. Temperature

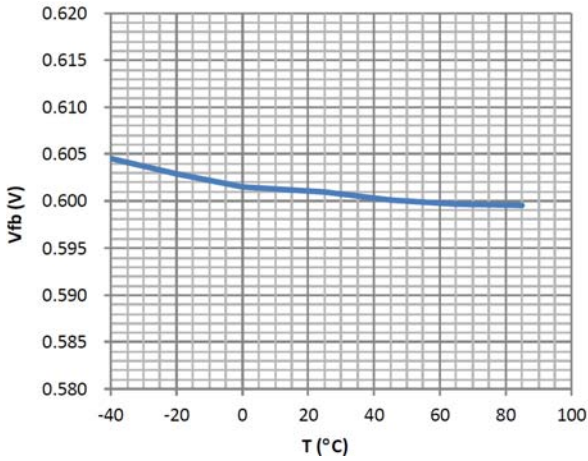

14.  $I_Q$  (No Switching)

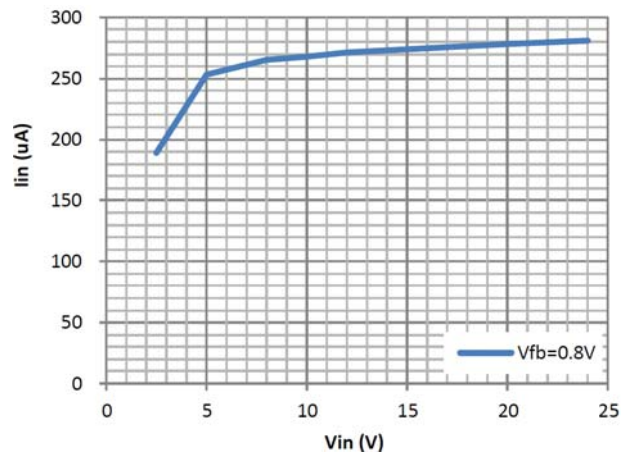

15. Enable Response

( $V_{IN}=5V$ ,  $V_{OUT}=12V$ ,  $I_{OUT}=800mA$ ,  $EN=0 \rightarrow 3V$ )

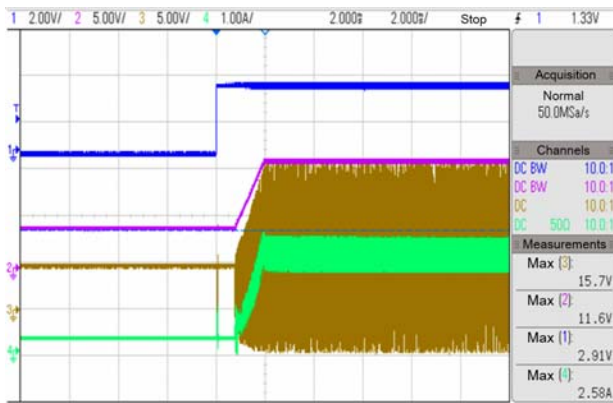

CH1: EN, CH2:  $V_{OUT}$ , CH2:  $V_{SW}$ , CH4:  $I_L$

16. Enable Response

( $V_{IN}=5V$ ,  $V_{OUT}=12V$ ,  $I_{OUT}=800mA$ ,  $EN=3 \rightarrow 0V$ )

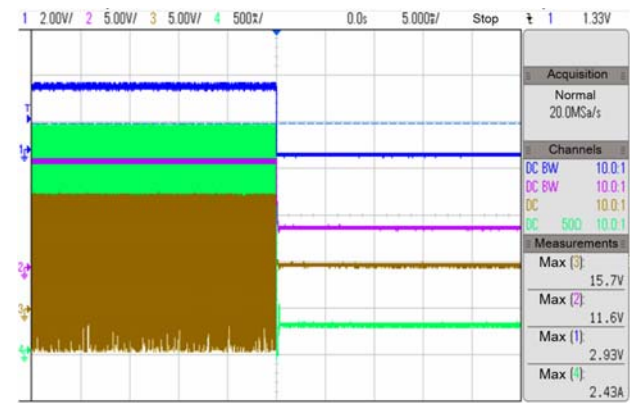

CH1: EN, CH2:  $V_{OUT}$ , CH2:  $V_{SW}$ , CH4:  $I_L$



**BLOCK DIAGRAM**

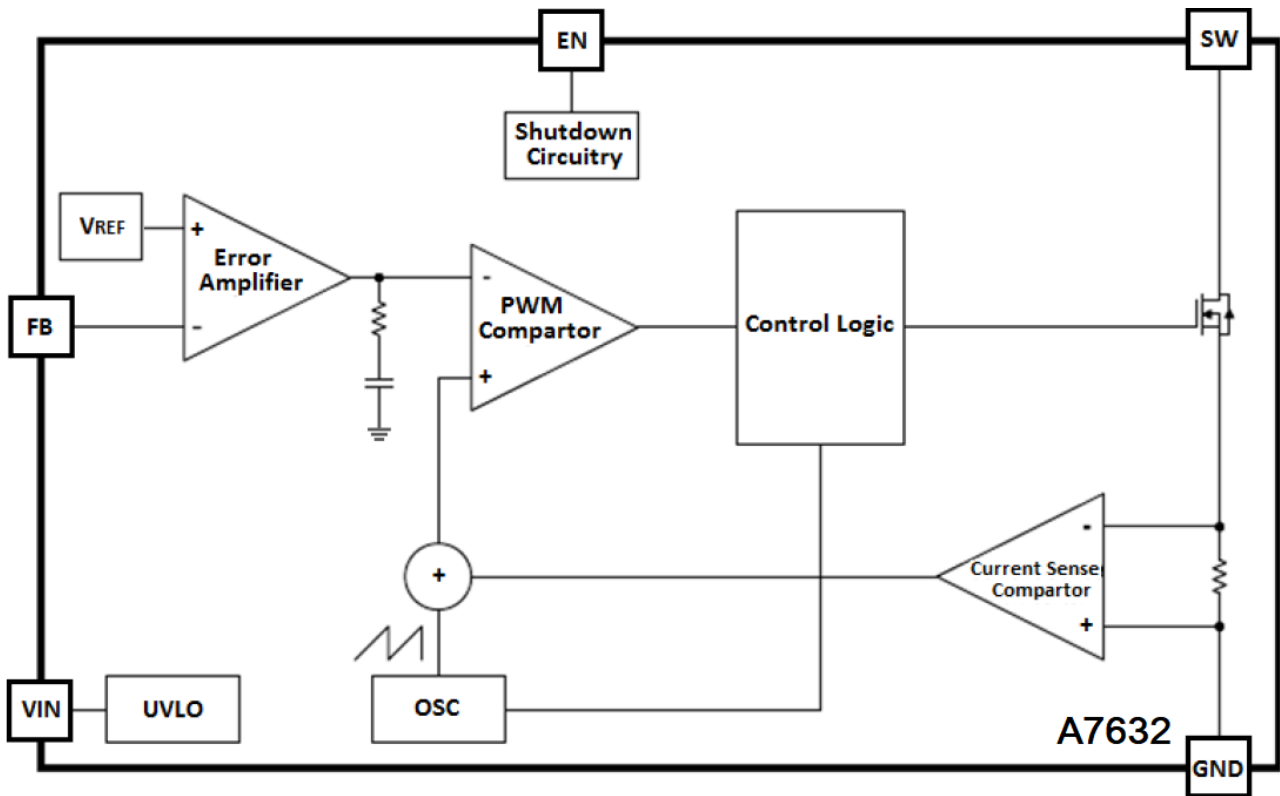





## DETAILED INFORMATION

The A7632 uses a fixed frequency, peak current mode boost regulator architecture to regulate voltage at the feedback pin. The operation of the A7632 can be understood by referring to the block diagram. At the start of each oscillator cycle the MOSFET is turned on through the control circuitry. To prevent sub-harmonic oscillations at duty cycles greater than 50%, a stabilizing ramp is added to the output of the current sense amplifier and the result is fed into the negative input of the PWM comparator. When this voltage equals the output voltage of the error amplifier the power MOSFET is turned off. The voltage at the output of the error amplifier is an amplified version of the difference between the 0.6V band gap reference voltage and the feedback voltage. In this way the peak current level keeps the output in regulation. If the feedback voltage starts to drop, the output of the error amplifier increases. These results in more current to flow through the power MOSFET, thus increasing the power delivered to the output. The A7632 has internal soft start to limit the amount of input current at startup and to also limit the amount of overshoot on the output. The A7632 includes a number of protection features including under-voltage lockout, current limiting, thermal shutdown protection and output over voltage protection. Output voltage protection works when FB short to the GND.

## APPLICATION INFORMATION

### Setting the Output Voltage

The internal reference  $V_{REF}$  is 0.6V (Typical). The output voltage is divided by a resistor divider, R1 and R2 to the FB pin. The output voltage is given by

$$V_{OUT} = V_{REF} \times \left( 1 + \frac{R1}{R2} \right)$$

### Inductor Selection

The recommended WSI04020E-4R7M values of inductor are 4.7 to 22 $\mu$ H. Suggest AiT Semi's WSI04020E-4R7M, small size and better efficiency are the major concerns for portable device, such as A7632 used for mobile phone. The inductor WSI04020E-4R7M have low core loss at 1.2MHz and low DCR for better efficiency. To avoid inductor saturation current rating should be considered.

### Capacitor Selection

Input and output ceramic capacitors of 22 $\mu$ F are recommended for A7632 applications. For better voltage filtering, ceramic capacitors with low ESR are recommended. X5R and X7R types are suitable because of their wider voltage and temperature ranges.



### Diode Selection

AiT Semi's Schottky diode SM140A is a good choice for A7632 because of its low forward voltage drop and fast reverses recovery. Using Schottky diode can get better efficiency. The high speed rectification SM140A is also a good characteristic of Schottky diode for high switching frequency. Current rating of the diode must meet the root mean square of the peak current and output average current multiplication as following:

$$I_D(\text{RMS}) \approx \sqrt{I_{\text{OUTX}} I_{\text{PEAK}}}$$

The diode's reverse breakdown voltage should be larger than the output voltage.

### Layout Consideration

When laying out the printed circuit board, the following checking should be used to ensure proper operation of the A7632.

Check the following in your layout:

1. The power traces, consisting of the GND trace, the SW trace and the  $V_{\text{IN}}$ , trace should be kept short, direct and wide.
2. Does the (+) plates of  $C_{\text{in}}$  connect to  $V_{\text{in}}$  as closely as possible. This capacitor provides the AC current to the internal power MOSFETs.
3. Keep the switching node SW away from the sensitive  $V_{\text{OUT}}$  node.
4. Keep the (-) plates of  $C_{\text{in}}$  and  $C_{\text{out}}$  as close as possible



**PACKAGE INFORMATION**

Dimension in SOT-26 (Unit: mm)

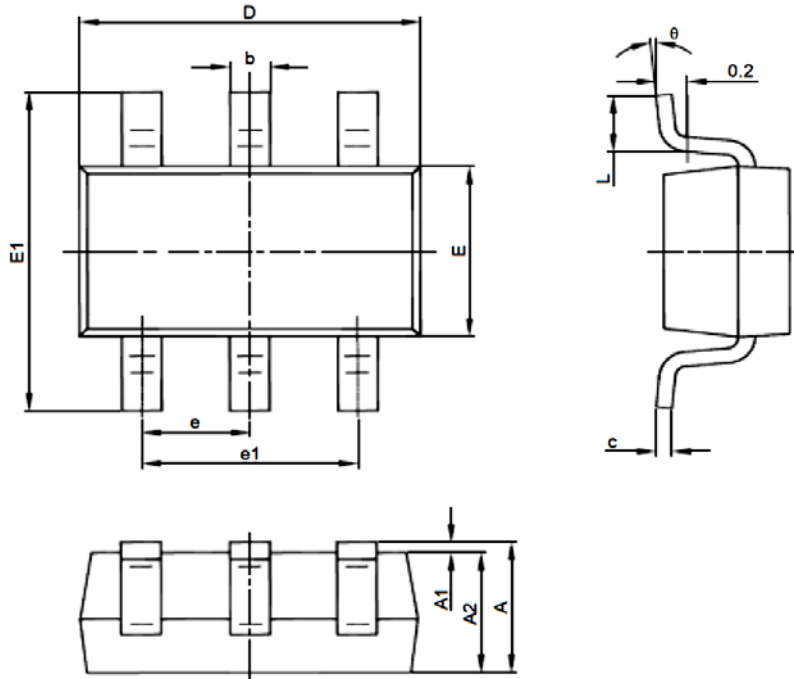

Symbol	Millimeters		
	Min	Nom	Max
A	1.100	1.2	1.400
A1	0.000	-	0.100
A2	1.000	1.100	1.300
b	0.200	0.400	0.500
c	0.100	0.15	0.250
D	2.700	2.900	3.100
E	1.500	1.600	1.800
E1	2.500	2.800	3.100
e	0.950 BSC		
e1	1.700	1.900	2.100
L	0.300	-	0.600
θ	0°	-	8°



## IMPORTANT NOTICE

AiT Semiconductor Inc. (AiT) reserves the right to make changes to any its product, specifications, to discontinue any integrated circuit product or service without notice, and advises its customers to obtain the latest version of relevant information to verify, before placing orders, that the information being relied on is current.

AiT Semiconductor Inc.'s integrated circuit products are not designed, intended, authorized, or warranted to be suitable for use in life support applications, devices or systems or other critical applications. Use of AiT products in such applications is understood to be fully at the risk of the customer. As used herein may involve potential risks of death, personal injury, or severe property, or environmental damage. In order to minimize risks associated with the customer's applications, the customer should provide adequate design and operating safeguards.

AiT Semiconductor Inc. assumes to no liability to customer product design or application support. AiT warrants the performance of its products of the specifications applicable at the time of sale.