



DESCRIPTION

The AL573 is an 8-bit D-type transparent latch with 3-state outputs. The device features latch enables (LE) and output enable (\overline{OE}) inputs. When LE is high, data at the inputs enter the latches. In this condition the latches are transparent, a latch output will change each time its corresponding D-input changes. When LE is low the latches store the information that was present at the inputs a set-up time preceding the high-to-low transition of LE.

The AL573 is available in SOP20 and TSSOP20 packages.

FEATURES

- Wide Power-Supply Range:1.65V to 5.5V
- Common 3-state Output Enable Input
- Balanced Propagation Delays
- Overvoltage Tolerant Inputs to 5.5V
- CMOS Low Power Consumption: 8 μ A(Max.)
- Low Input Current: 1 μ A(Max.)
- Extended Temperature: -40°C to +125°C

APPLICATION

- Power Sub-Station Controls
- Industrial
Personal Electronics
- Test and Measurement Solutions
- Patient Monitoring

ORDERING INFORMATION

Package Type	Part Number	
SOP20 SPQ: 1,500pcs/Reel	M20	AL573M20R
		AL573M20VR
TSSOP20 SPQ: 4,000pcs/Reel	TMX20	AL573TMX20R
		AL573TMX20VR
Note	V: Halogen Free Package R: Tape & Reel	
AiT provides all RoHS products		

FUNCTIONAL DIAGRAM

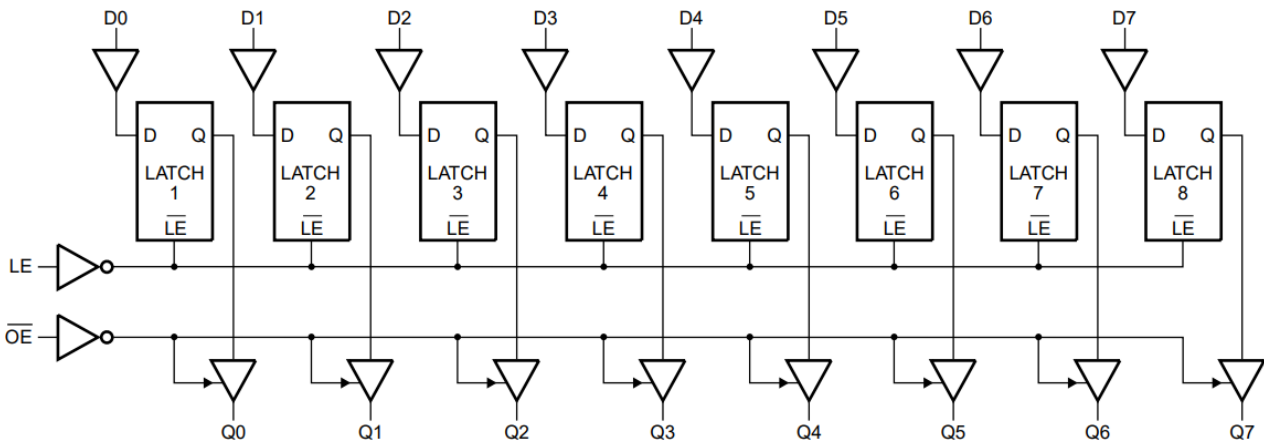



PIN DESCRIPTION

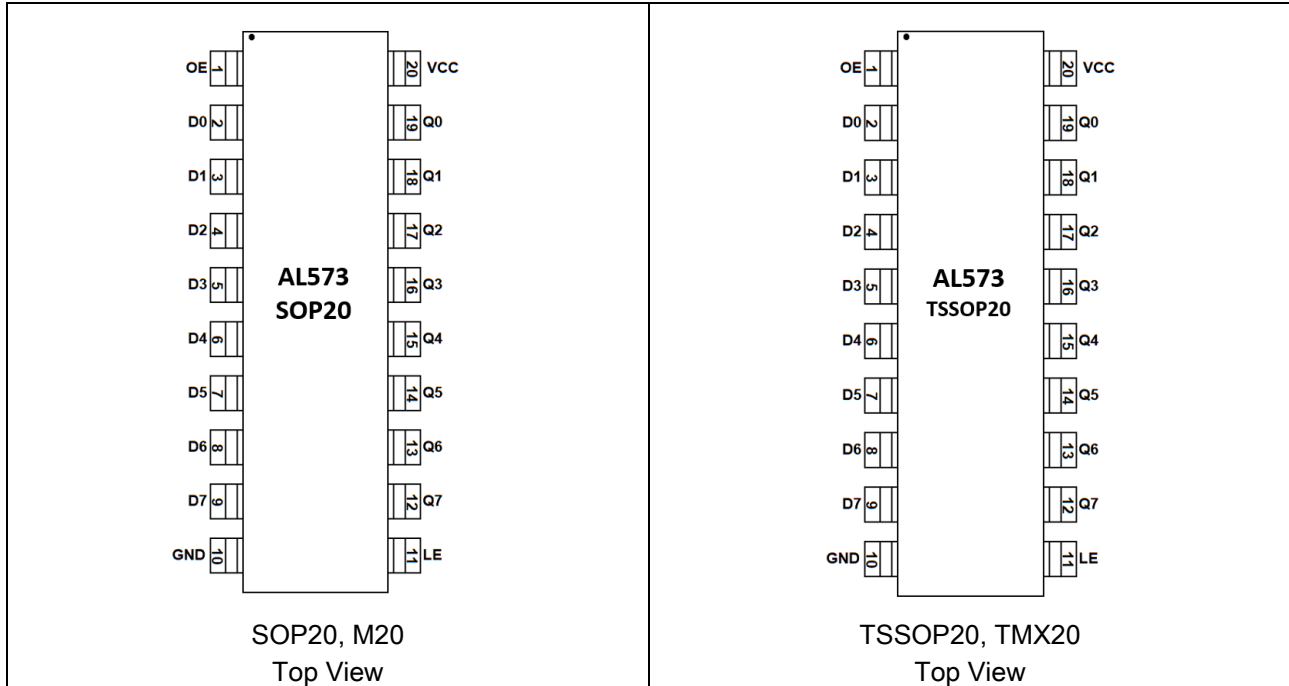

Pin #		Symbol	I/O Type*	Description
SOP20	TSSOP20			
1		\overline{OE}	I	3-State output enable input (Active Low)
2		D0	I	Data input
3		D1	I	Data input
4		D2	I	Data input
5		D3	I	Data input
6		D4	I	Data input
7		D5	I	Data input
8		D6	I	Data input
9		D7	I	Data input
10		GND	G	Ground.
	11	LE	I	Latch enable input (Active High)
	12	Q7	O	Data output
	13	Q6	O	Data output
	14	Q5	O	Data output
	15	Q4	O	Data output
	16	Q3	O	Data output
	17	Q2	O	Data output
	18	Q1	O	Data output
	19	Q0	O	Data output
	20	V _{CC}	P	Supply voltage

* I=Input, O=Output, P=Power.



FUNCTION TABLE

H = HIGH voltage level; h = HIGH voltage level one set-up time prior to the HIGH-to-LOW LE transition

L = LOW voltage level; l = LOW voltage level one set-up time prior to the HIGH-to-LOW LE transition

Z = high-impedance OFF-state

Inputs			Internal Latch	Output
\overline{OE}	LE	Dn		Qn
L	H	L	L	L
		H	H	H
L	L	l	L	L
		H	H	H
H	L	l	L	Z
		H	H	Z

ABSOLUTE MAXIMUM RATINGS

V _{CC} , Supply Voltage Range		-0.5V~+7V
I _{IK} , Input Clamp Current	V _I < 0	±50mA
I _{OK} , Output Clamp Current	V _O < 0	±50mA
I _O , Continuous Output Current	V _O = 0 to V _{CC}	±50mA
Continuous Current Through V _{CC} or GND		±100mA
θ _{JA} , Package Thermal Impedance ⁽¹⁾	SOP20	40°C/W
	TSSOP20	40°C/W
T _J , Junction Temperature ⁽²⁾		-40°C ~ +150°C
T _{STG} , Storage Temperature		-65°C ~ +150°C
ESD Ratings		
V _(ESD) , Electrostatic Discharge	Human-Body Model (HBM)	±2000V
	Charged-Device Model (CDM)	±1000V
	Machine Model (MM)	±200V

Stresses above may cause permanent damage to the device. These are stress ratings only, and functional operation of the device at these or any other conditions beyond those indicated in the Electrical Characteristics is not implied. Exposure to absolute maximum rating conditions for extended periods may affect device reliability.

(1) The package thermal impedance is calculated in accordance with JESD-51.

(2) The maximum power dissipation is a function of T_{J(MAX)}, R_{θJA}, and T_A. The maximum allowable power dissipation at any ambient temperature is PD = (T_{J(MAX)} - T_A) / R_{θJA}. All numbers apply for packages soldered directly onto a PCB.

**RECOMMENDED OPERATING CONDITIONS**Voltages are referenced to GND (ground = 0 V) ⁽¹⁾⁽²⁾

Parameter	Symbol	Conditions	Min.	Typ.	Max.	Unit
Supply Voltage	V _{CC}	-	1.65	-	5.5	V
High-Level Input Voltage ⁽³⁾	V _{IH}	1.65V~1.95V	V _{CC} ×0.65	-	-	V
		2.3V~2.7V	1.70	-	-	
		3V~3.6V	2.00	-	-	
		4.5V~5.5V	V _{CC} ×0.70	-	-	
Low-level Input Voltage ⁽³⁾	V _{IL}	1.65V~1.95V	-	-	V _{CC} ×0.35	V
		2.3V~2.7V	-	-	0.70	
		3V~3.6V	-	-	0.80	
		4.5V~5.5V	-	-	V _{CC} ×0.30	
Input Voltage	V _I	-	0	-	5.50	V
Output Voltage	V _O	-	0	-	V _{CC}	V
High-Level Output Current	I _{OH}	1.65V~1.95V	-	-	-4	mA
		2.3V~2.7V	-	-	-8	
		3V~3.6V	-	-	-24	
		4.5V~5.5V	-	-	-32	
Low-Level Output Current	I _{OL}	1.65V~1.95V	-	-	4	mA
		2.3V~2.7V	-	-	8	
		3V~3.6V	-	-	24	
		4.5V~5.5V	-	-	32	
Input Transition Rise or Fall Rate(Δt/Δv)	-	1.65V~1.95V	-	-	20	ns/V
		2.3V~2.7V	-	-	20	
		3V~3.6V	-	-	10	
		4.5V~5.5V	-	-	5	
Operating Free-Air Temperature	T _A	-	-40	-	125	°C

(1) All unused or driven (floating) data inputs (I/Os) of the device must be held at logic HIGH or LOW (preferably V_{CC} or GND) to ensure proper device operation and minimize power.

(2) All unused control inputs must be held at V_{CC} or GND to ensure proper device operation and minimize power consumption.

(3) For V_{CC} values not specified in the data sheet, V_{IH} min = V_{CC} × 0.7 V, V_{IL} max = V_{CC} × 0.3 V.



ELECTRICAL CHARACTERISTICS

At recommended operating conditions; voltages are referenced to GND (ground = 0 V)

Parameter	Conditions	V _{CC}	Temp	Min. ⁽¹⁾	Typ. ⁽²⁾	Max. ⁽¹⁾	Unit
V _{OH}	I _{OH} = -100μA, V _I =V _{IH}	1.65V~4.5V	+25°C	V _{CC} -0.1	-	-	V
	I _{OH} = -4mA, V _I =V _{IH}	1.65V		1.2	-	-	
	I _{OH} = -8mA, V _I =V _{IH}	2.5V		1.9	-	-	
	I _{OH} = -24mA, V _I =V _{IH}	3.3V		2.4	-	-	
	I _{OH} = -32mA, V _I =V _{IH}	4.5V		3.8	-	-	
V _{OL}	I _{OL} = 100μA, V _I =V _{IL}	1.65V~4.5V		-	-	0.10	V
	I _{OL} = 4mA, V _I =V _{IL}	1.65V		-	-	0.45	
	I _{OL} = 8mA, V _I =V _{IL}	2.5V		-	-	0.30	
	I _{OL} = 24mA, V _I =V _{IL}	3.3V		-	-	0.55	
	I _{OL} = 32mA, V _I =V _{IL}	4.5V		-	-	0.55	
I _I	V _I = 5.5V or GND	0V~5.5V	+25°C	-	±0.1	±1	μA
			Full	-	-	±5	
I _{OFF}	V _I or V _O = 5.5V	0V	+25°C	-	±0.1	±1	μA
			Full	-	-	±10	
I _{OZ} ⁽³⁾	V _O = V _{CC} or GND	1.65V~5.5V	+25°C	-	±0.1	±1	μA
			Full	-	-	±10	
I _{CC}	V _I = V _{CC} or GND ⁽⁴⁾ I _O = 0	1.65V~5.5V	+25°C	-	0.1	8	μA
			Full	-	-	80	
C _I	f=1MHz	1.65V~5.5V	+25°C	-	3	-	pF
C _{PD}	f=1MHz	No Load	+25°C	-	13	-	pF

(1) Limits are 100% production tested at 25°C. Limits over the operating temperature range are ensured through correlations using statistical quality control (SQC) method.

(2) Typical values represent the most likely parametric norm as determined at the time of characterization. Actual typical values may vary over time and will also depend on the application and configuration.

(3) For I/O ports, the parameter I_{OZ} includes the input leakage current.

(4) Hold all unused data inputs of the device at V_{CC} or GND to assure proper device operation.



SWITCHING CHARACTERISTICS

Voltages are referenced to GND (ground = 0 V); CL = 50 pF unless otherwise specified

Parameter	V _{CC} =1.8V±0.15V			V _{CC} =2.5V±0.2V			V _{CC} =3.3V±0.3V			V _{CC} =5V±0.5V			Unit
	Min.	Typ.	Max.	Min.	Typ.	Max.	Min.	Typ.	Max.	Min.	Typ.	Max.	
t _{pd} , C _L =50pF, from D (input) to Q (output)	-	25	-	-	12	-	-	10	-	-	8	-	ns
t _{pd} , C _L =50pF, from LE (input) to Q (output)	-	37	-	-	23	-	-	18	-	-	14	-	ns
t _{en} , C _L =50pF, from \overline{OE} (input) to Q (output)	-	27	-	-	17	-	-	14	-	-	10	-	ns
t _{dis} , C _L =50pF, from \overline{OE} (input) to Q (output)	-	22	-	-	14	-	-	12	-	-	9	-	ns
t _t , C _L =50pF to any Q (output)	-	20	-	-	10	-	-	8	-	-	7	-	ns
t _{pd} , C _L =150pF, from D (input) to Q (output)	-	35	-	-	17	-	-	16	-	-	14	-	ns
t _{pd} , C _L =150pF, from LE (input) to Q (output)	-	46	-	-	26	-	-	21	-	-	17	-	ns
t _{en} , C _L =150pF, from \overline{OE} (input) to Q (output)	-	36	-	-	21	-	-	17	-	-	12	-	ns
t _{dis} , C _L =150pF, from \overline{OE} (input) to Q (output)	-	33	-	-	23	-	-	21	-	-	20	-	ns
t _t , C _L =150pF to any Q (output)	-	56	-	-	21	-	-	16	-	-	15	-	ns
t _w , Pulse duration, LE high	-	75	-	-	65	-	-	60	-	-	30	-	ns
t _{su} , Setup time, data before LE ↓	-	16	-	-	16	-	-	16	-	-	16	-	ns
t _h , Hold time, data after LE ↓	-	19	-	-	17	-	-	16	-	-	16	-	ns



BLOCK DIAGRAM

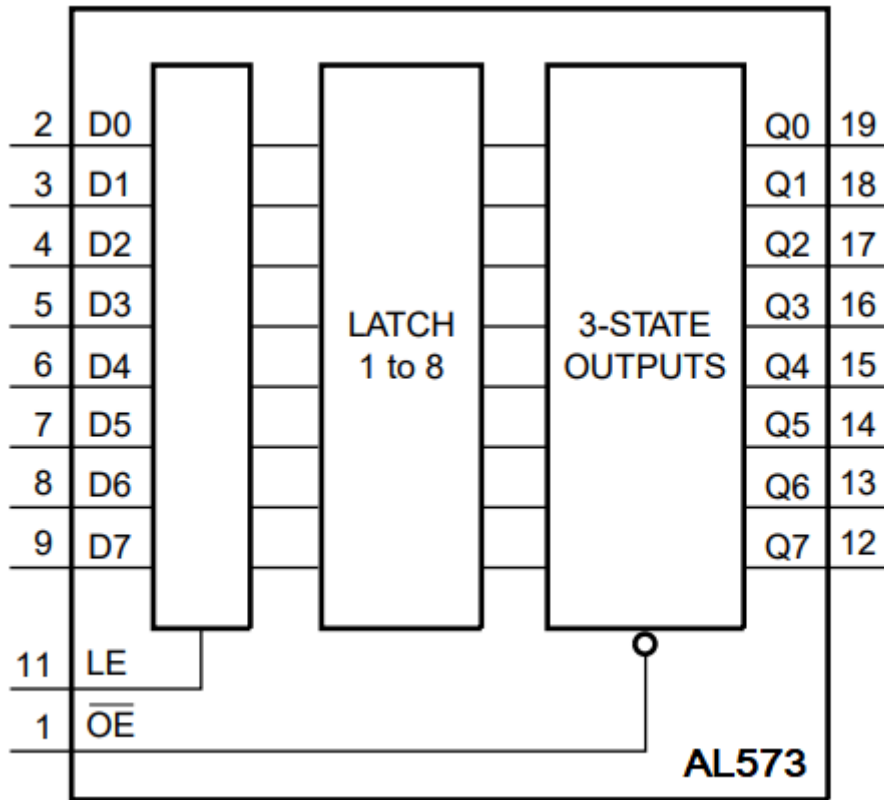



DETAILED INFORMATION

Parameter Measurement Information

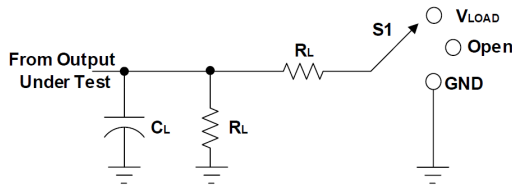

TEST	S1
t_{pd}	Open
t_{PLZ} / t_{PZL}	V_{LOAD}
t_{PHZ} / t_{PZH}	GND

V_{CC}	Inputs		V_M	V_{LOAD}	C_L	R_L	V_{Δ}
	V_I	t_r/t_f					
$1.8V \pm 0.15V$	V_{CC}	$\leq 2ns$	$V_{CC}/2$	$2 \times V_{CC}$	50pF or 150pF	2k Ω	0.15V
$2.5V \pm 0.2V$	V_{CC}	$\leq 2ns$	$V_{CC}/2$	$2 \times V_{CC}$	50pF or 150pF	2k Ω	0.15V
$3.3V \pm 0.3V$	3V	$\leq 2.5ns$	1.5V	6V	50pF or 150pF	2k Ω	0.3V
$5V \pm 0.5V$	V_{CC}	$\leq 2.5ns$	$V_{CC}/2$	$2 \times V_{CC}$	50pF or 150pF	2k Ω	0.3V

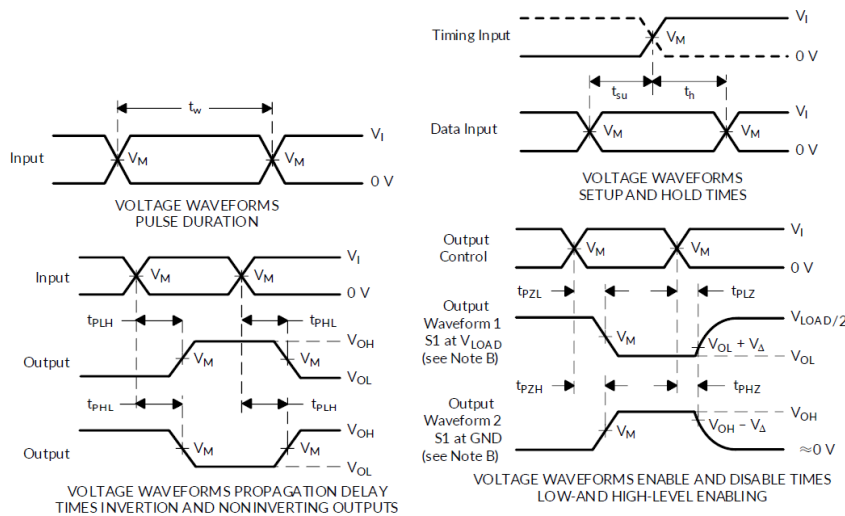

Figure 1. Load Circuit and Voltage Waveforms

- (A) C_L includes probe and jig capacitance.
- (B) Waveform 1 is for an output with internal conditions such that the output is low, except when disabled by the output control. Waveform 2 is for an output with internal conditions such that the output is high, except when disabled by the output control.
- (C) All input pulses are supplied by generators having the following characteristics: $PRR \leq 10 \text{ MHz}$, $Z_0 = 50\Omega$.
- (D) The outputs are measured one at a time, with one transition per measurement.
- (E) t_{PLZ} and t_{PHZ} are the same as t_{dis} .
- (F) t_{PZL} and t_{PZH} are the same as t_{en} .
- (G) t_{PLH} and t_{PHL} are the same as t_{pd} .
- (H) All parameters and waveforms are not applicable to all devices.



PACKAGE INFORMATION

Dimension in SOP20 (Unit: mm)

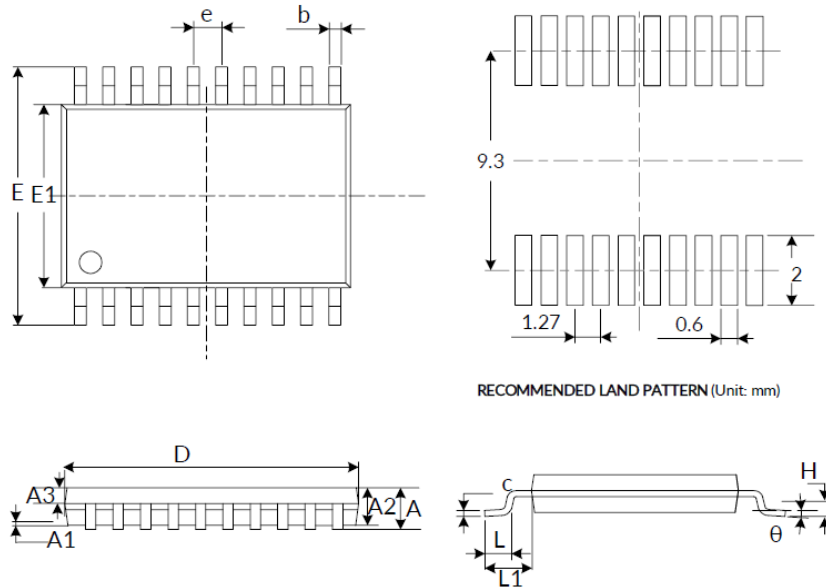

RECOMMENDED LAND PATTERN (Unit: mm)

Symbol	Min.	Max.
A	-	2.650
A1	0.100	0.300
A2	2.250	2.350
A3	0.970	1.070
b	0.390	0.470
c	0.250	0.290
D	12.700	12.900
E	10.100	10.500
E1	7.400	7.600
e	1.270 BSC	
L	0.700	1.000
L1	1.400 REF	
H	0.250 TYP	
θ	0°	8°



Dimension in TSSOP20 Package (Unit: mm)

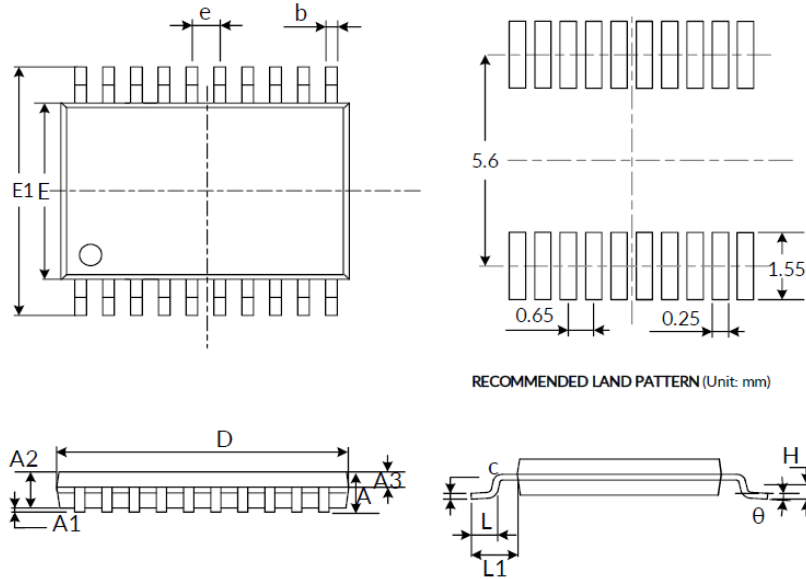

Symbol	Min.	Max.
A	-	1.200
A1	0.050	0.150
A2	0.800	1.050
A3	0.390	0.490
b	0.200	0.290
c	0.130	0.170
D	6.400	6.600
E	4.300	4.500
E1	6.200	6.600
e	0.650 BSC	
L	0.450	0.750
L1	1.000 REF	
H	0.250 TYP	
θ	0°	8°



IMPORTANT NOTICE

AiT Semiconductor Inc. (AiT) reserves the right to make changes to any its product, specifications, to discontinue any integrated circuit product or service without notice, and advises its customers to obtain the latest version of relevant information to verify, before placing orders, that the information being relied on is current.

AiT Semiconductor Inc.'s integrated circuit products are not designed, intended, authorized, or warranted to be suitable for use in life support applications, devices or systems or other critical applications. Use of AiT products in such applications is understood to be fully at the risk of the customer. As used herein may involve potential risks of death, personal injury, or serve property, or environmental damage. In order to minimize risks associated with the customer's applications, the customer should provide adequate design and operating safeguards.

AiT Semiconductor Inc. assumes to no liability to customer product design or application support. AiT warrants the performance of its products of the specifications applicable at the time of sale.