



## DESCRIPTION

The A8160A-030 is a step-up DC-DC converter specifically designed for driving white LEDs with a constant current.

The internal MOSFET can support up to 10 White LEDs for backlighting and OLED power application, and the internal soft start function can reduce the inrush current.

The A8160A-030 uses current mode, fixed frequency of approximately 1.0MHz architecture to regulate the LED current through an external current sense resistor. The low feedback voltage of 300mV can minimize power dissipation.

Other features include current limit protection, thermal shutdown protection, under-voltage lockout (UVLO), and over-voltage function.

The A8160A-030 is available in SOT-26 package.

## ORDERING INFORMATION

Package Type	Part Number	
SOT-26 SPQ: 3,000pcs/Reel	E6	A8160AE6R-030
		A8160AE6VR-030
Note	R: Tape & Reel V: Halogen free Package	
AiT provides all RoHS products		

## FEATURES

- $V_{IN}$  Operating Range : 2.5V to 5.5V
- Internal Power N-MOSFET Switch
- Wide Range for PWM Dimming (100Hz to 200kHz)
- 1.0MHz Switch Frequency
- 300mV Feedback Voltage
- 1.2A SW Current Limit
- Minimize the External Component Counts
- Internal Compensation
- Over Voltage Protection
- Available in SOT-26 Package

## APPLICATION

- Cellular Phones and Digital Cameras
- PDAs and Smart Phones and MP3 and OLED
- Portable Instruments
- High-light LED Flash

## TYPICAL APPLICATION

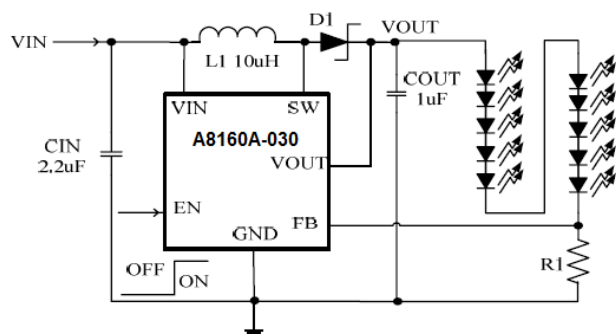



## PIN DESCRIPTION

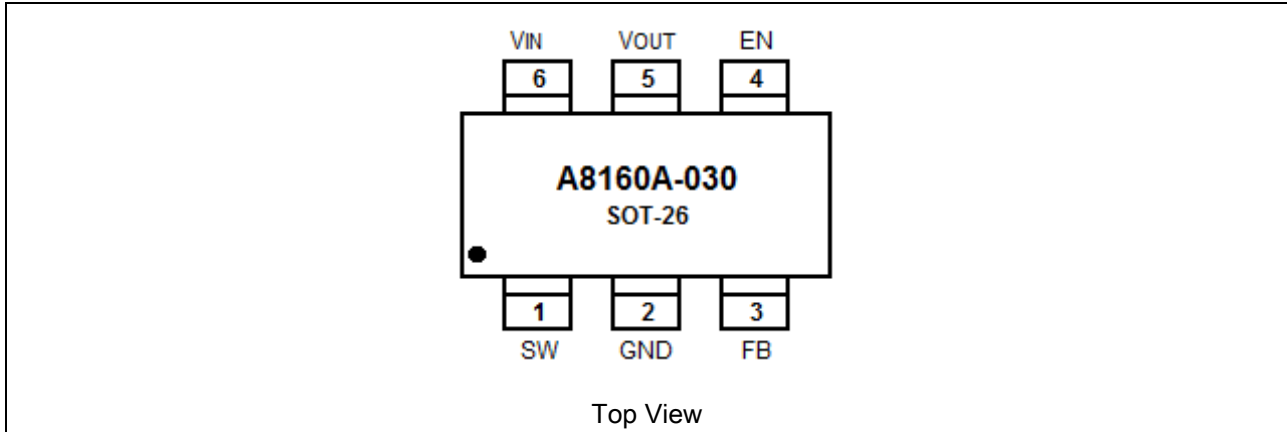

Pin #	Symbol	Function
1	SW	Switching Pin.
2	GND	Ground Pin. The exposed pad must be soldered to a large PCB and connected to GND for maximum power dissipation.
3	FB	Feedback Pin. Feedback voltage is 0.3V.
4	EN	Chip Enable (Active High).
5	V <sub>OUT</sub>	Output Voltage Pin.
6	V <sub>IN</sub>	Input Supply.



## ABSOLUTE MAXIMUM RATINGS

V <sub>IN</sub> , Supply Input Voltage		-0.3V ~ 6V
SW, Switching Pin		-0.3V ~ 40V
V <sub>OUT</sub>		-0.3V ~ 40V
Other Pins		-0.3V ~ 6V
P <sub>D</sub> , Power Dissipation, @ T <sub>A</sub> = 25°C	SOT-26	0.392W
θ <sub>JA</sub> , Package Thermal Resistance <sup>NOTE1</sup>	SOT-26	255°C/W
Lead Temperature (Soldering, 10 sec.)		260°C
Junction Temperature		150°C
Storage Temperature Range		-65°C ~ 150°C

Stress beyond above listed "Absolute Maximum Ratings" may lead permanent damage to the device. These are stress ratings only and operations of the device at these or any other conditions beyond those indicated in the operational sections of the specifications are not implied. Exposure to absolute maximum rating conditions for extended periods may affect device reliability.

NOTE1: θ<sub>JA</sub> is measured in the natural convection at T<sub>A</sub> = 25°C on a low effective single layer thermal conductivity test board of JEDEC 51-3 thermal measurement standard.

## RECOMMENDED OPERATING CONDITIONS <sup>NOTE2</sup>

Parameter	Min	Max.	Unit
Junction Temperature Range	-40	125	°C
Ambient Temperature Range	-40	85	°C

NOTE2: The device is not guaranteed to function outside its operating conditions.



## ELECTRICAL CHARACTERISTICS

$V_{IN}=3.7V$ ,  $C_{IN}=2.2\mu F$ ,  $C_{OUT}=1\mu F$ ,  $I_{OUT}=20mA$ ,  $L=10\mu H$ ,  $T_A = 25^\circ C$ , unless otherwise specified

Parameter	Symbol	Conditions	Min.	Typ.	Max.	Unit
Input Voltage	$V_{IN}$		2.5	-	5.5	V
Under Voltage Lock Out	$V_{UVLO}$		2	2.2	2.45	V
UVLO Hystersis			-	0.1	-	V
Quiescent Current	$I_Q$	FB=1.5V, No Switching	-	400	600	$\mu A$
Supply Current	$I_{IN}$	FB=0V, Switching	-	1	2	mA
Shutdown Current	$I_{SHDN}$	$V_{EN} < 0.4V$	-	1	4	$\mu A$
Line Regulation		$V_{IN}=3$ to 4.3V	-	1	-	%
Load Regulation		1mA to 20mA	--	1	-	%
Operation Frequency	$f_{OSC}$		0.75	1	1.25	MHz
Maximum Duty Cycle			90	92	-	%
Clock Rate			0.1	-	200	kHz
Feedback Reference Voltage	$V_{REF}$		285	300	315	mV
On Resistance	$R_{DS(ON)}$		-	0.7	1.2	$\Omega$
EN Threshold	Logic-High Voltage	$V_{IH}$	1.4	-	-	V
	Logic-Low Voltage	$V_{IL}$	-	-	0.5	V
EN Sink Current	$I_{IH}$		-	1	-	$\mu A$
EN Hystersis			-	0.1	-	V
Over-Voltage Threshold	$V_{OVP}$		34	36	38	V
Over-Current Threshold	$I_{OCP}$		-	1.2	-	A
OTP	$T_{OTP}$		-	160	-	$^\circ C$
OTP Hystersis			-	30	-	$^\circ C$



## TYPICAL PERFORMANCE CHARACTERISTICS

1.  $\eta$  vs.  $V_{IN}$

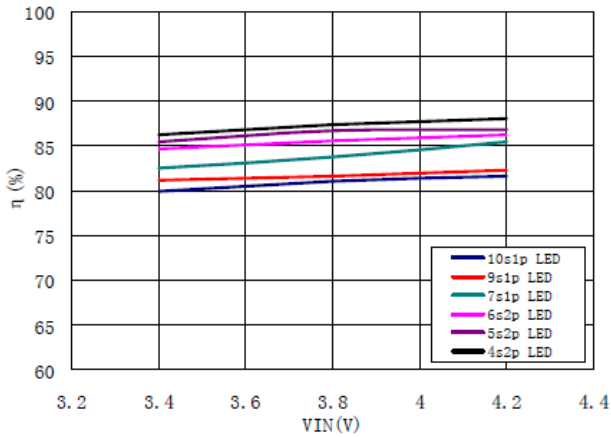

2.  $I_Q$  vs.  $V_{IN}$

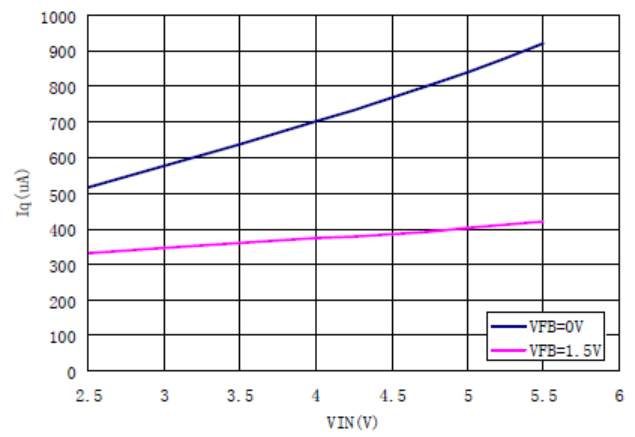

3.  $F_{OSC}$  vs.  $V_{IN}$

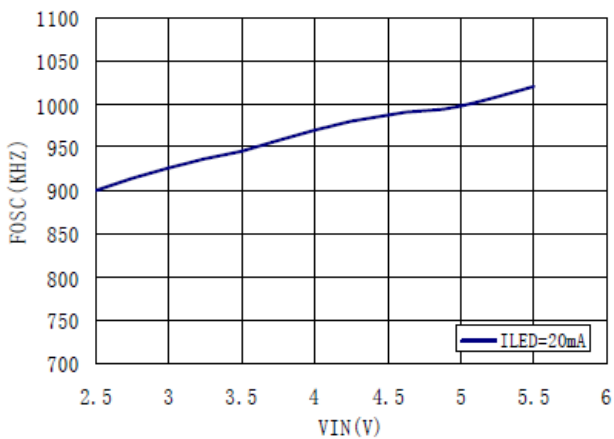

4.  $V_{FB}$  vs.  $V_{IN}$

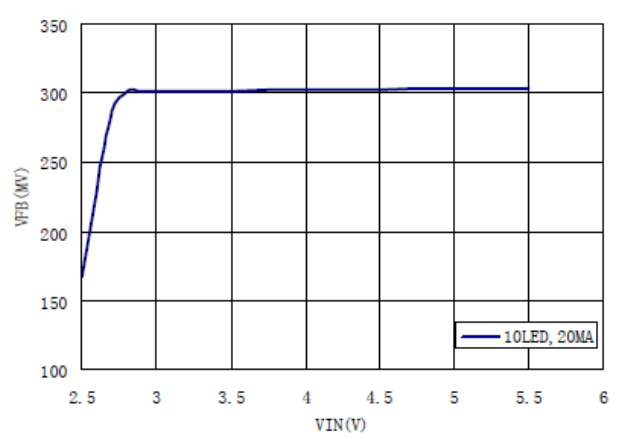

5.  $V_{EN}$  vs.  $V_{IN}$

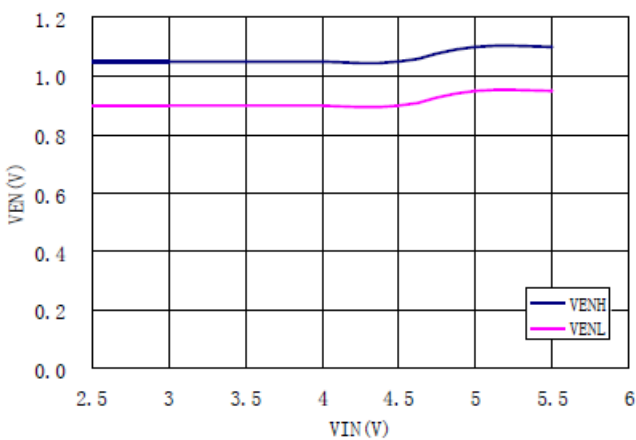

6.  $I_{LED}$  vs. DUTY

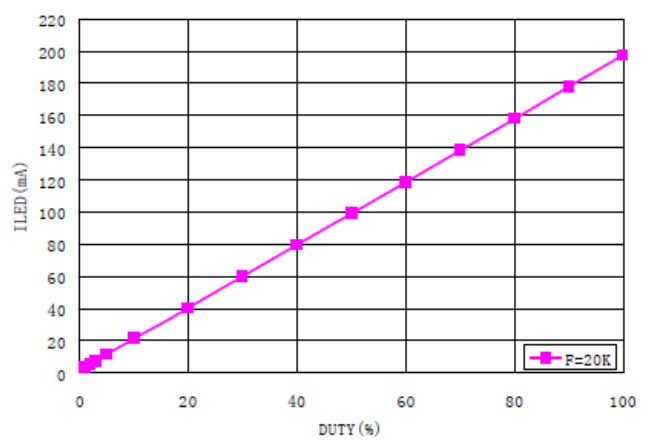



7.  $V_{FB}$  vs.  $I_{LED}$

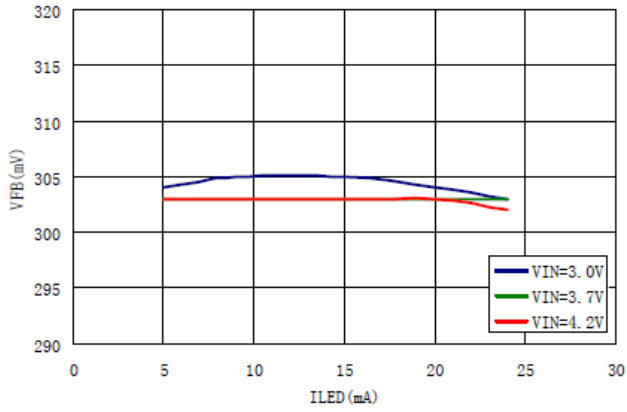

8. Power on from EN

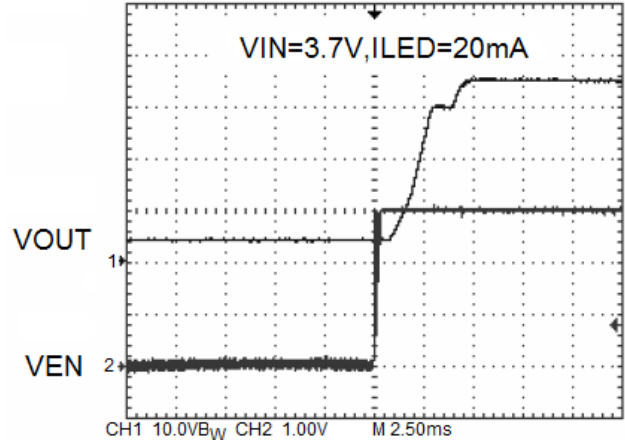



**BLOCK DIAGRAM**

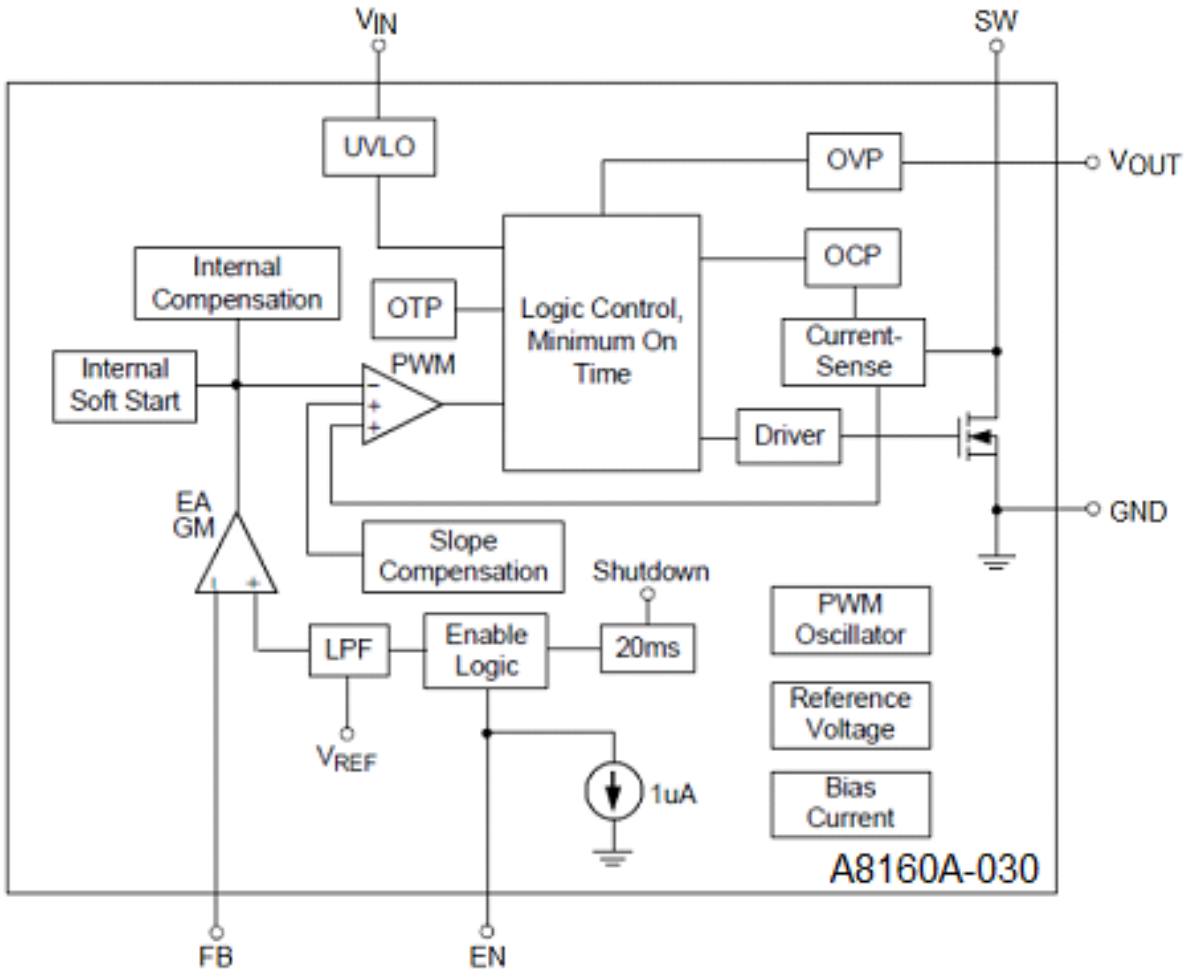



## DETAILED INFORMATION

### Applications Information

#### LED Current Setting

The loop of Boost structure will keep the FB pin voltage equal to the reference voltage  $V_{REF}$ . Therefore, when  $R_{SET}$  connects FB pin and GND, the current flows from  $V_{OUT}$  through LED and  $R_{SET}$  to GND will be decided by the current on  $R_{SET}$ , which is equal to following equation.

$$I_{LED} = \frac{V_{REF}}{R_{SET}}$$

#### Dimming Control

##### a. Using a PWM Signal to EN Pin

For the brightness dimming control of the A8160A-030, the IC provides typically 300mV feedback voltage when the EN pin is pulled constantly high. However, EN pin allows a PWM signal to reduce this regulation voltage by changing the PWM duty cycle to achieve LED brightness dimming control. The relationship between the duty cycle and FB voltage can be calculated as following equation.

$$V_{FB} = \text{Duty} \times 300\text{mV}$$

Where

Duty = duty cycle of the PWM signal

300mV = internal reference voltage

As shown in Figure 1, the duty cycle of the PWM signal is used to cut the internal 300mV reference voltage. An internal low pass filter is used to filter the pulse signal. And then the reference voltage can be made by connecting the output of the filter to the error amplifier for the FB pin voltage regulation.

However, the internal low pass filter 3db frequency is 500Hz. When the dimming frequency is lower than 500Hz,  $V_A$  is also a PWM signal and the LED current is controlled directly by this signal. When the frequency is higher than 500Hz, PWM is filtered by the internal low pass filter and the  $V_A$  approach a DC signal. And the LED current is a DC current which eliminate the audio noise.

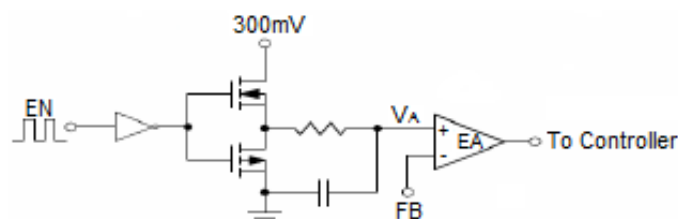

Figure 1 Block Diagram of Programmable FB Voltage Using PWM Signal





### b. Using a DC Voltage

Using a variable DC voltage to adjust the brightness is a popular method in some applications. The dimming control using a DC voltage circuit is shown in Figure 2. As the DC voltage increases, the current flows through R3 increasingly and the voltage drop on R3 increase, i.e. the LED current decreases. For example, if the  $V_{DC}$  range is from 0V to 2.8V and  $V_{REF}$  is equal to 0.3V, the selection of resistors in Figure 2 sets the LED current from 21mA to 0mA. The LED current can be calculated by the following equation.

$$I_{LED} = \frac{V_{REF} - \frac{R3 \times (V_{DC} - V_{REF})}{R4}}{R_{SET}}$$

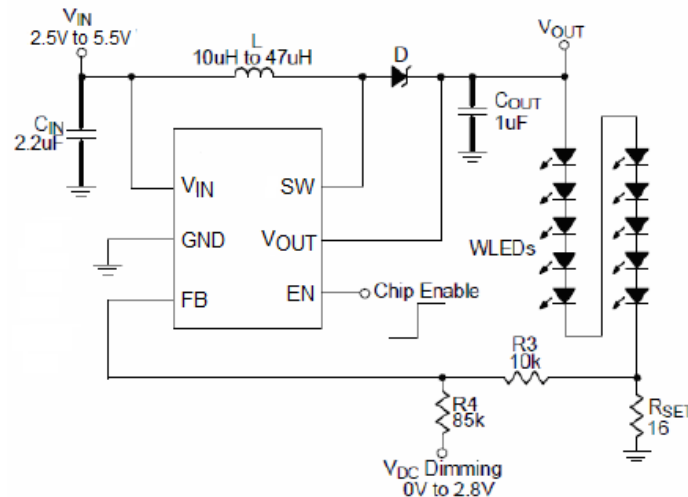

Figure 2 Dimming Control Using a DC Voltage

### c. Using a Filtered PWM signal

Another common application is using a filtered PWM signal as an adjustable DC voltage for LED dimming control. A filtered PWM signal acts as the DC voltage to regulate the output current. The recommended application circuit is shown as Figure 3. In this circuit, the output ripple depends on the frequency of PWM signal. For smaller output voltage ripple (<100mV), the recommended frequency of 2.8V PWM signal should be above 2kHz. To fix the frequency of PWM signal and change the duty cycle of PWM signal can get different output current. The LED current can be calculated by the following equation.

$$I_{LED} = \frac{V_{REF} - \frac{R3 \times (V_{PMW} \times Duty - V_{REF})}{R4 + R_{DC}}}{R_{SET}}$$

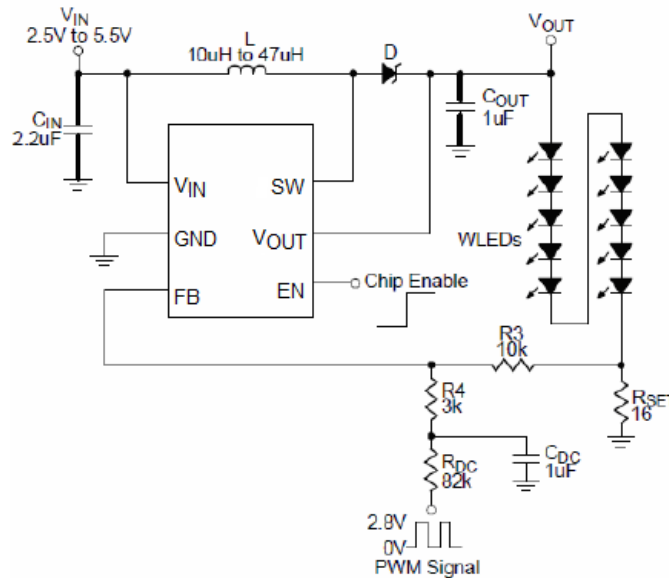

Figure 3 Dimming Control Using a Filtered PWM Signal

By the above equation and the application circuit shown in Figure 3. We can get the relationship between the LED current and PWM duty cycle. For example, when the PWM duty is equal to 60%, the LED current will be equal to 8.6mA. When the PWM duty is equal to 40%, the LED current will be equal to 12.7mA.

### Power Sequence

In order to assure the normal soft start function for suppressing the inrush current the input voltage should be ready before EN pulls high.

### Soft-Start

The function of soft-start is made for suppressing the inrush current to an acceptable value at the beginning of power-on. The A8160A-030 provides a built-in soft-start function by clamping the output voltage of error amplifier so that the duty cycle of the PWM will be increased gradually in the soft-start period.

### Current Limiting

The current flow through inductor as charging period is detected by a current sensing circuit. As the value comes across the current limiting threshold, the N-MOSFET will be turned off so that the inductor will be forced to leave charging stage and enter discharging stage. Therefore, the inductor current will not increase over the current limiting threshold.



### OVP/UVLO/OTP

The Over Voltage Protection is detected by a junction breakdown detecting circuit. Once  $V_{OUT}$  goes over the detecting voltage, SW pin stops switching and the power N-MOSFET will be turned off. Then, the  $V_{OUT}$  will be clamped to be near  $V_{OVP}$ . As the output voltage is higher than a specified value or input voltage is lower than a specified value, the chip will enter protection mode to prevent abnormal function. As the die temperature is higher than 160°C, the chip also will enter protection mode. The power MOSFET will be turned off during protection mode to prevent abnormal operation.

### Capacitor Selection

Input ceramic capacitor of 2.2uF and output ceramic capacitor of 1uF are recommended for the A8160A-030 applications for driving 10 series WLEDs. For better voltage filtering, ceramic capacitors with low ESR are recommended. X5R and X7R types are suitable because of their wider voltage and temperature ranges.

### Inductor Selection

The recommended value of inductor for 10 WLEDs applications is from 10uH to 47uH. Small size and better efficiency are the major concerns for portable devices, such as the A8160A-030 used for mobile phone. The inductor should have low core loss at 1.0MHz and low DCR for better efficiency. The inductor saturation current rating should be considered to cover the inductor peak current.

### Thermal Considerations

For continuous operation, do not exceed absolute maximum operation junction temperature. The maximum power dissipation depends on the thermal resistance of IC package, PCB layout, the rate of surroundings airflow and temperature difference between junction to ambient. The maximum power dissipation can be calculated by following formula:

$$P_{D(MAX)} = (T_{J(MAX)} - T_A) / \theta_{JA}$$

Where  $T_{J(MAX)}$  is the maximum operation junction temperature,  $T_A$  is the ambient temperature and the  $\theta_{JA}$  is the junction to ambient thermal resistance.

For the recommended operating conditions specification of A8160A-030, the maximum junction temperature of the die is 125°C. The junction to ambient thermal resistance  $\theta_{JA}$  is layout dependent. The junction to ambient thermal resistance for SOT-26 package is 255°C/W on the standard JEDEC 51-3 single layer thermal test board. The maximum power dissipation at  $T_A=25^\circ\text{C}$  can be calculated by following formula:

$$P_{D(MAX)} = (125^\circ\text{C} - 25^\circ\text{C}) / (255^\circ\text{C/W}) = 0.392\text{W}$$

The maximum power dissipation depends on operating ambient temperature for fixed  $T_{J(MAX)}$  and thermal resistance  $\theta_{JA}$ . For A8160A-030 packages, the Figure 4 of derating curves allows the designer to see the effect of rising ambient temperature on the maximum power allowed.

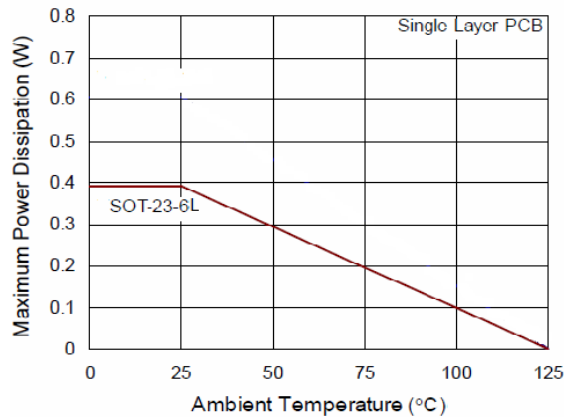

Figure 4 Derating Curves for A8160A-030 Packages

### Layout Consideration

For best performance of the A8160A-030, the following guidelines must be strictly followed.

- Input and Output capacitors should be placed close to the IC and connected to ground plane to reduce noise coupling.
- The GND and Exposed Pad should be connected to a strong ground plane for heat sinking and noise protection.
- Keep the main current traces as possible as short and wide.
- SW node of DC-DC converter is with high frequency voltage swing. It should be kept at a small area.
- Place the feedback components as close as possible to the IC and keep away from the noisy devices.

### Typical Application Circuits

#### 1. LED Backlighting

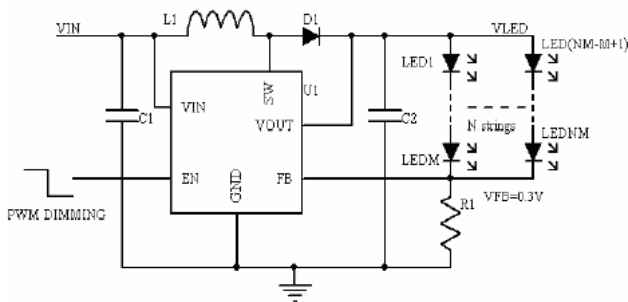

#### 2. High-light LED Flash

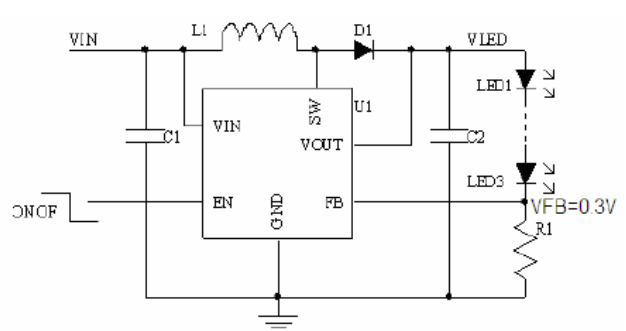



**PACKAGE INFORMATION**

Dimension in SOT-26 Package (Unit: mm)

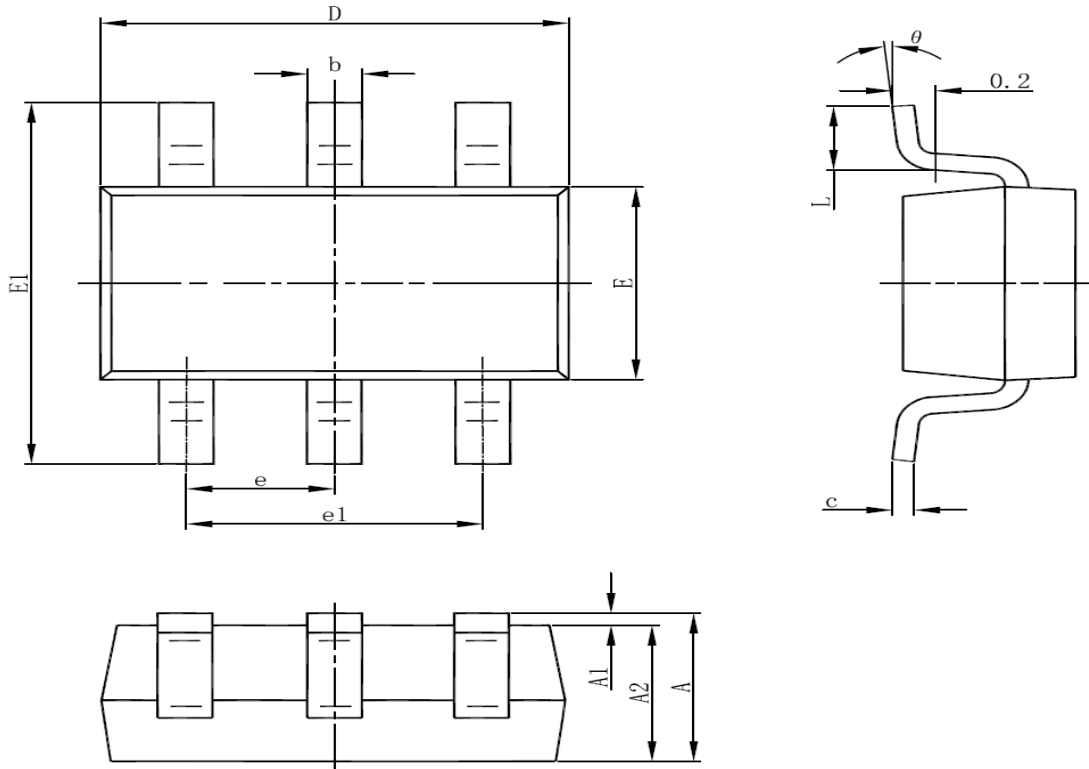

Symbol	Millimeters		Inches	
	Min	Max	Min	Max
A	1.050	1.250	0.041	0.049
A1	0.000	0.100	0.000	0.004
A2	1.050	1.150	0.041	0.045
b	0.300	0.500	0.012	0.020
c	0.100	0.200	0.004	0.008
D	2.820	3.020	0.111	0.119
E	1.500	1.700	0.059	0.067
E1	2.650	2.950	0.104	0.116
e	0.950(BSC)		0.037(BSC)	
e1	1.800	2.000	0.071	0.079
L	0.300	0.600	0.012	0.024
θ	0°	8°	0°	8°



## IMPORTANT NOTICE

AiT Semiconductor Inc. (AiT) reserves the right to make changes to any its product, specifications, to discontinue any integrated circuit product or service without notice, and advises its customers to obtain the latest version of relevant information to verify, before placing orders, that the information being relied on is current.

AiT Semiconductor Inc.'s integrated circuit products are not designed, intended, authorized, or warranted to be suitable for use in life support applications, devices or systems or other critical applications. Use of AiT products in such applications is understood to be fully at the risk of the customer. As used herein may involve potential risks of death, personal injury, or server property, or environmental damage. In order to minimize risks associated with the customer's applications, the customer should provide adequate design and operating safeguards.

AiT Semiconductor Inc. assumes to no liability to customer product design or application support. AiT warrants the performance of its products of the specifications applicable at the time of sale.