



## DESCRIPTION

The AD8816 is one channel H-Bridge driver IC, it provides integrated motor-driver solution for toys, robotics, consumer products and other low voltage or battery-powered motion control applications.

The AD8816 maximum operational voltage is 25.0V. It can supply up to 1.5A of output continuous current and 3.5A of output peak current. There is internal shutdown function for over-temperature protection and over-current protection ( $I_{OC\ P} = 4.5\ A$ ).

The AD8816 is available in SOP8 Package.

## ORDERING INFORMATION

Package Type	Part Number	
SOP8 SPQ: 4,000psc/Reel	M8	AD8816M8R
		AD8816M8VR
Note	V: Halogen free Package R: Tape & Reel	
AiT provides all RoHS products		

## FEATURES

- Operating Voltage Range up to 25V
- Maximum Continuous Current Output up to 1.5A
- Low  $R_{DS(ON)}$  for Highly Efficient H-Bridge Output.
- Support PWM Control
- Over Current Protection
- Over Temperature Protection
- Low Standby Current
- Low Quiescent Current
- Available in SOP8 Package

## APPLICATION

- Robotics (R/C servo, Sweeping robot)
- Toys (R/C car, R/C aircraft)
- Any relevant DC motor applications

## TYPICAL APPLICATION

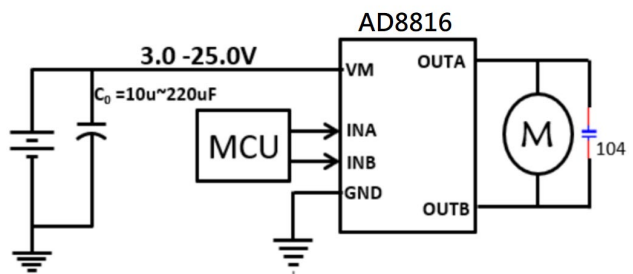



**PIN DESCRIPTION**

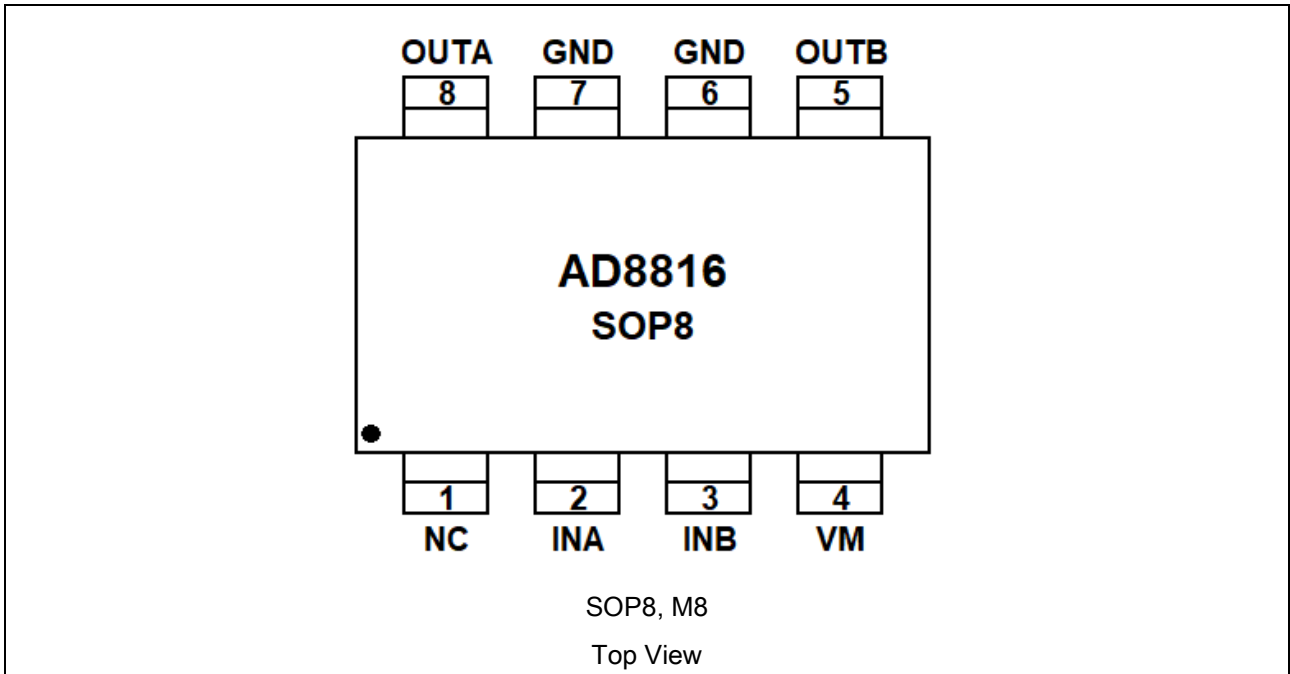

Pin #	Symbol	Type	Function
1	NC	NC	No Connection
2	INA	I	Input INA
3	INB	I	Input INB
4	VM	P	Power Supply for H-Bridge , Connection 10uF or bigger capacitor between VDD and GND
5	OUTB	O	Output OUTB
6	GND	P	Ground
7	GND	P	Ground
8	OUTA	O	Output OUTA , Connection 0.1uF between OUTA and OUTB



## ABSOLUTE MAXIMUM RATINGS

T<sub>A</sub> = 25°C, unless otherwise specified.

Parameter	Symbol	Min	Max	Unit
Power Supply	VM	-0.30	30	V
Input Logic	INA, INB	-0.30	7	V
ESD (HBM)	VM, INA, INB, OUTA, OUTB	-	4	kV
Operation Temp.	T <sub>J</sub>	-40	150	°C
Storage Temp.	T <sub>stg</sub>	-65	150	°C
Thermal Resistance	θ <sub>JA</sub>	-	160	°C/W
<b>Recommended Operating Conditions</b>				
Power Supply	VM	3	25	V
Input Logic	INA, INB	0	5	V
Output Contiguous Current *	I <sub>OUTA</sub> , I <sub>OUTB</sub>	0	1.50	A

Stress beyond above listed "Absolute Maximum Ratings" may lead permanent damage to the device. These are stress ratings only and operations of the device at these or any other conditions beyond those indicated in the operational sections of the specifications are not implied. Exposure to absolute maximum rating conditions for extended periods may affect device reliability.

\* Using 25mm<sup>2</sup> FR4 Signal layer PCB (1 oz) under VM=7.2V test.

## ELECTRICAL CHARACTERISTICS

V<sub>M</sub>=7.20V, T<sub>A</sub>=25°C, R<sub>LOAD</sub>=20, unless otherwise noted

Parameter	Symbol	Conditions	Min.	Typ.	Max.	Unit
<b>H-BRIDGE FETS</b>						
On Resistance	R <sub>DSON</sub>	I <sub>OUT</sub> =1A	-	0.35	-	Ω
<b>INA / INB</b>						
Input High Level Voltage	V <sub>INH</sub>	-	1.50	-	5	V
Input Low Level Voltage	V <sub>INL</sub>	-	0	-	0.70	V
Pulldown Resistance	R <sub>PD</sub>	-	-	100	200	KΩ
<b>SUPPLY CURRENT</b>						
Standby Current	I <sub>VM_OFF</sub>	INA=INB=0	-	1.50	10	μA
Operation Current	I <sub>VM_ON</sub>	-	-	2	4	mA
<b>THERMAL PROTECTION</b>						
Thermal Shutdown Protection	T <sub>OTSD</sub>	-	-	160	-	°C
Thermal Shutdown hysteresis	T <sub>HYS</sub>	-	-	50	-	



**BLOCK DIAGRAM**

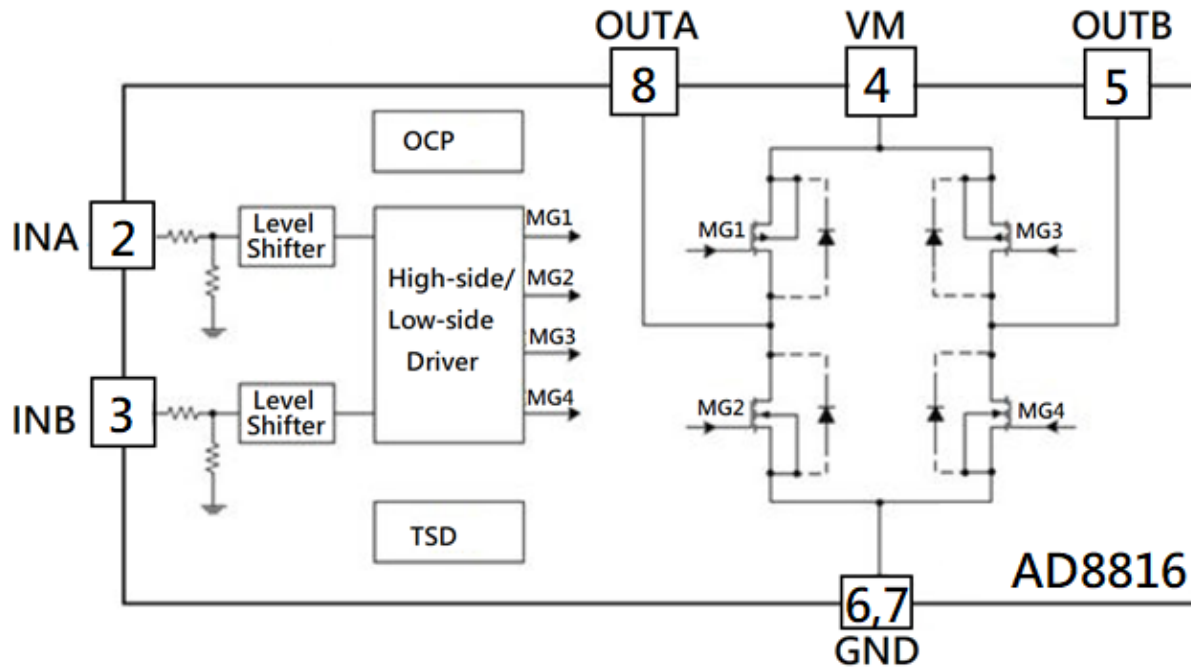



## INPUT-OUTPUT LOGICAL TABLE

INA	INB	OUTA	OUTB	Function	Current
L	L	Hi-Z	Hi-Z	Stop	$I_{VM\_OFF}$
H	L	H	L	Forward	$I_{VM\_ON}$
L	H	L	H	Reverse	$I_{VM\_ON}$
H	H	L	L	Brake	$I_{VM\_ON}$

## DETAILED INFORMATION

### Schematic Descriptions

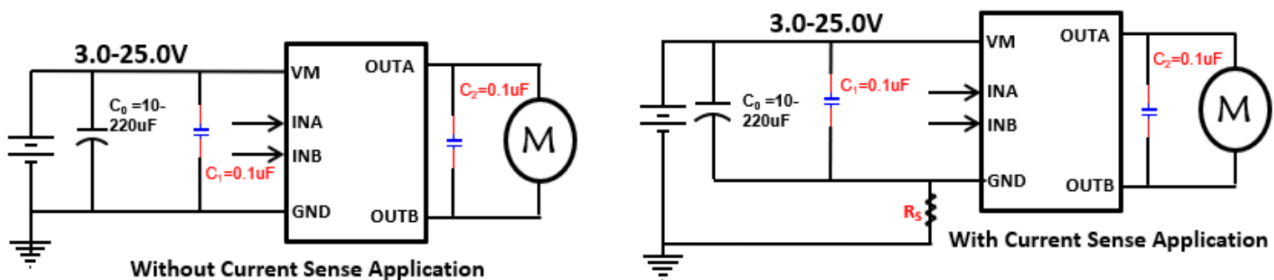

1. This simplified schematic is only as reference in DC motor driver application.
2.  $C_0$  ,  $C_1$ : Power supply VM pin capacitor:
  - 1) The capacitor can reduce the power spike when the motor is in motion. To avoid the IC directly damaged by the VM peak voltage. It also can stabilize the power supply voltage and reduce its ripples.
  - 2) The  $C_0$  capacitor can compensate power when motor starts running.
  - 3) The capacitor value determines the stability of the VM during motor in motion. If the large voltage power or a heavy loading motor is used, then a larger capacitor would be needed.
  - 4) On the PCB configuration, the  $C_0$  ,  $C_1$  must be mounted as close as possible to VM pin .
3.  $C_2$  : The across-motor capacitor
  - 1) The  $C_2$  capacitors can reduce the power spike of motor in start running. A  $0.1\mu F$  capacitor is recommended.
  - 2) The  $C_2$  capacitor must be added to the general application.
4.  $R_S$  : The sense resistor in current sense application
  - 1) Need to sense output current, the  $R_S$  is recommended to added between IC GND and PCB ground.
  - 2) The  $C_0$ ,  $C_1$  negative terminal is recommend connection to IC GND.



## Operating Mode

H-Bridge basic operating mode :

A) Stop mode

Definition : When  $INA=INB= L$ , then  $OUTA=OUTB=Hi-Z$

B) Forward mode

Definition : When  $INA=H$ ,  $INB=L$ , then  $OUTA=H$ ,  $OUTB=L$

C) Reverse mode

Definition : When  $INA=L$ ,  $INB=H$ , then  $OUTB=H$ ,  $OUTA=L$

D) Brake mode

Definition : When  $INA=INB= H$  , then  $OUTA=OUTB=L$

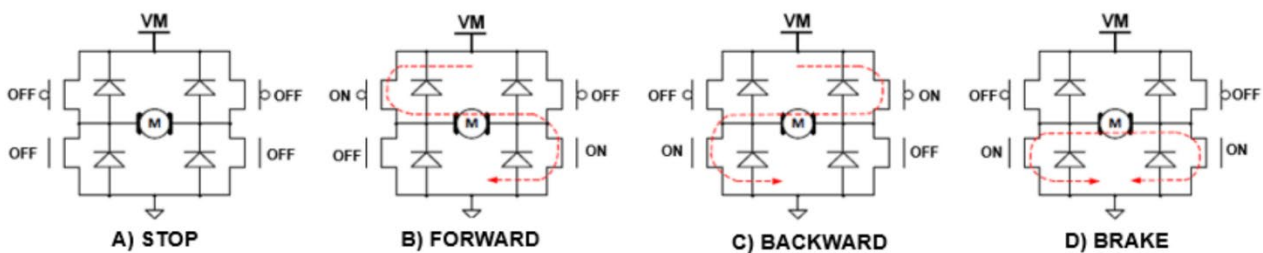

e) PWM mode A

When the input signal  $INA$  is a PWM signal,  $INB=0$  or  $INA=0$ , and  $INB$  is a PWM signal, the rotational speed of the motor will be affected by PWM signal duty cycle control. In this mode, the motor drive circuit switches between On-and-Stop mode, where all power transistors are turned off and the energy stored inside the motor can only be slowly released through the power MOSFET's body diode.

Note: Due to the presence of a high impedance state in the operating state, the rotational speed of the motor cannot be precisely controlled by the duty cycle of the PWM signal. If the frequency of the PWM signal is too high, the motor will not start.

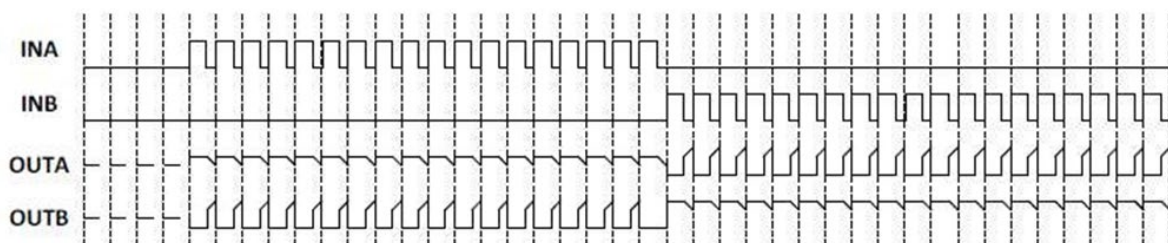

PWM mode A signal waveform



f) PWM mode B

When the input INA is a PWM signal, INB=1 or INA=1, and INB is a PWM signal, the motor's rotational speed is affected by PWM signal duty cycle control. In this mode, the motor drive circuit outputs between the Conduction and Brake modes, where the energy the motor stores is quickly released through the NMOS on the lower side.

Note: Due to the braking state in the working state, the motor energy can be released quickly, and the speed of the motor can be accurately controlled by the duty cycle of the PWM signal, but it must be noted that if the PWM signal frequency is too low, the motor will not be able to rotate smoothly continuously due to entering the Brake mode.

To reduce motor noise, it is recommended the PWM signal frequency is greater than 10KHz and less than 50KHz.

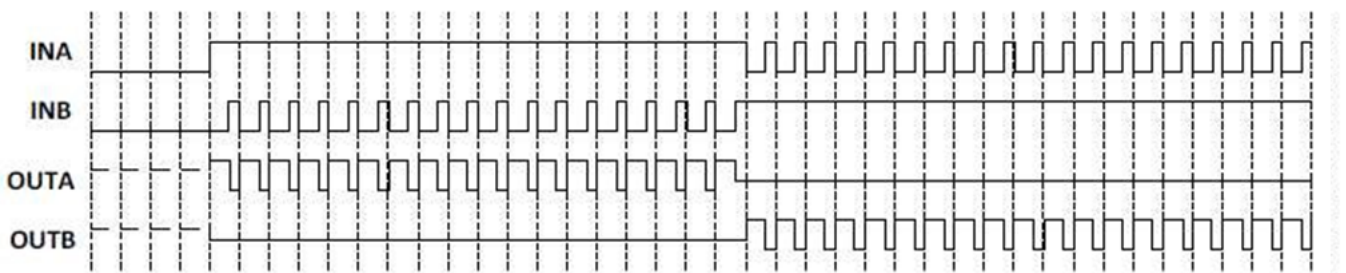

**PWM mode B signal waveform**

### Protection Mechanisms

1) Over-current protection (OCP)

While the IC conducts a large current, 4.5A (Typ.), the internal over-current protection function will be triggered. The device enters protection mode of auto-recover to avoid damaging IC and system.

2) Over-temperature protection

If the IC junction temperature exceeds 180 °C (Typ.), the internal over-temperature protection function will be triggered, partial FETs in the H-bridge are disabled, that will ensure the safety of customers' products. If the IC junction temperature falls to 120 °C(Typ.), the IC resumes automatically.



## PACKAGE INFORMATION

Dimension in SOP8 (Unit: mm)

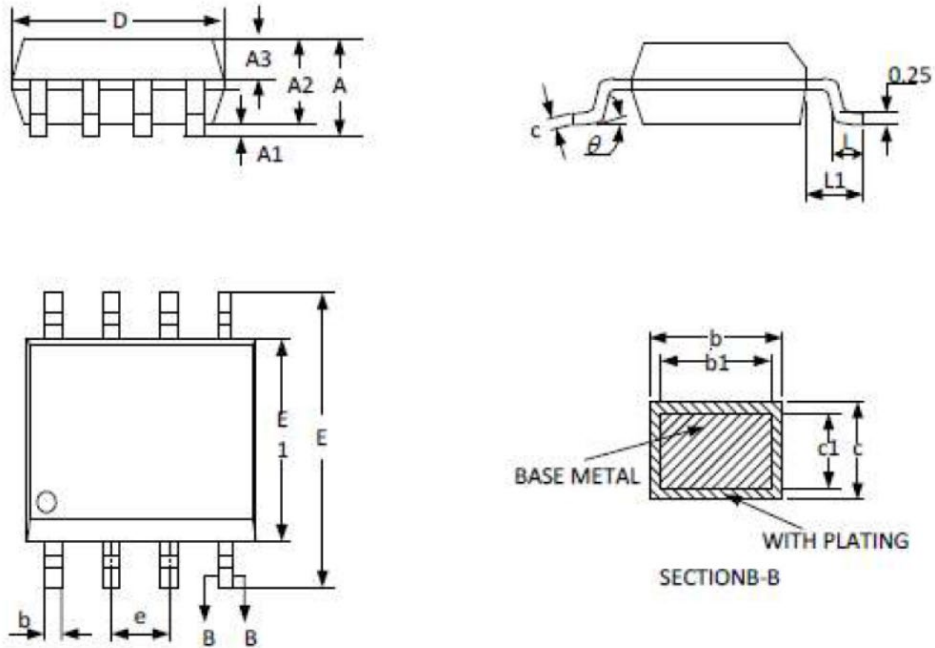

Symbol	Min	Max
A	-	1.77
A1	0.08	0.28
A2	1.20	1.60
A3	0.55	0.75
b	0.39	0.48
b1	0.38	0.43
c	0.21	0.26
c1	0.19	0.21
D	4.70	5.10
E	5.80	6.20
E1	3.70	4.10
e	1.27BSC	
L	0.50	0.80
L1	1.05BSC	
θ	0°	8°





## IMPORTANT NOTICE

AiT Semiconductor Inc. (AiT) reserves the right to make changes to any its product, specifications, to discontinue any integrated circuit product or service without notice, and advises its customers to obtain the latest version of relevant information to verify, before placing orders, that the information being relied on is current.

AiT Semiconductor Inc.'s integrated circuit products are not designed, intended, authorized, or warranted to be suitable for use in life support applications, devices or systems or other critical applications. Use of AiT products in such applications is understood to be fully at the risk of the customer. As used herein may involve potential risks of death, personal injury, or severe property, or environmental damage. In order to minimize risks associated with the customer's applications, the customer should provide adequate design and operating safeguards.

AiT Semiconductor Inc. assumes no liability to customer product design or application support. AiT warrants the performance of its products of the specifications applicable at the time of sale.