



●FEATURE

1. High performance (Isat) realized by metal dust core.
2. Low loss realized with low DCR
3. Capable of corresponding high frequency
4. Operating Temperature: -40°C ~ +125°C
5. Compliant with AEC-Q200



●APPLICATION

DC/DC Converter

●ORDERING INFORMATION

<u>WSL</u>	<u>201610</u>	<u>U</u>	<u>-R10</u>	<u>M</u>	<u>Q</u>
Series	Dimension (L*W*H)	Material code	Inductance (uH)	Tolerance M=±20%,N=±30%	AEC-Q

●SHAPE AND DIMENSION

Type: 201610

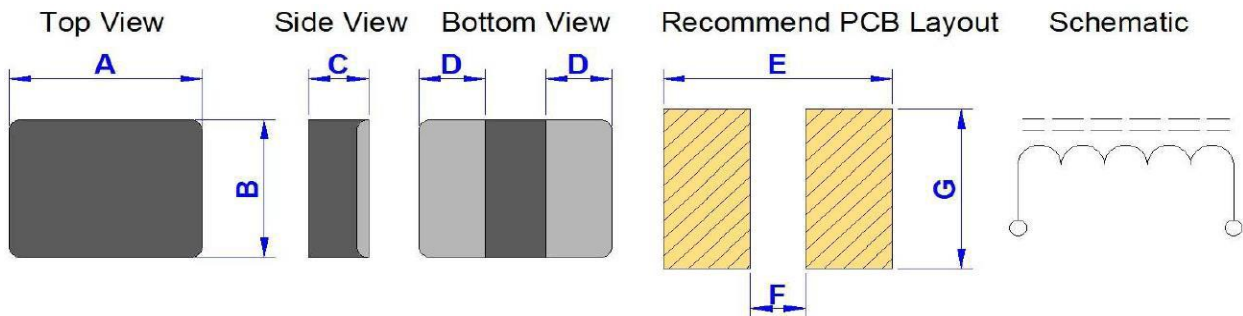

Type:

04015,04018,04020,05012,05015,05018,05020,05030,06012,06015,06018,06020,06024,06030,06040,06050,08030,08040,08050,08060,10020,10030,10040,10050,10060,10070,12035,12040,12050,12060,12065

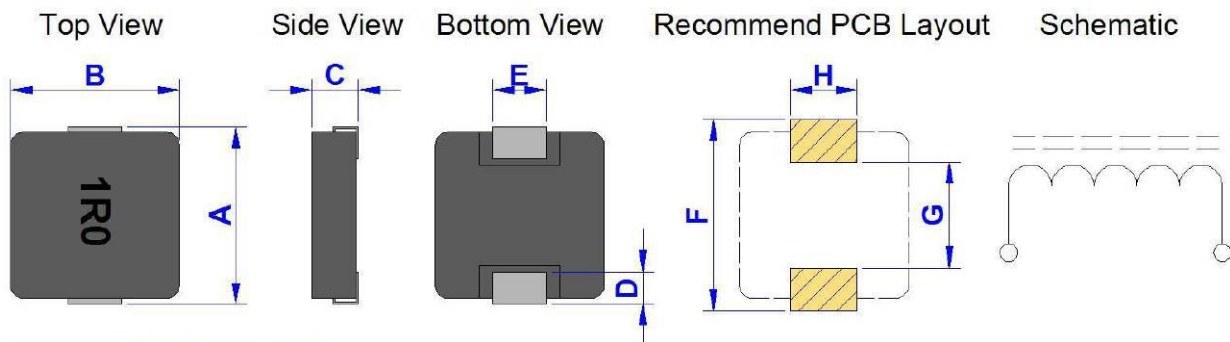

Marking : Inductance code



●SPECIFICATION

Unit: mm

TYPE	A	B	C	D	E	F	G	H
201610	2.0±0.2	1.6±0.2	1.0 Max	0.7±0.3	2.1 REF.	0.5 REF.	1.7 REF.	-
04015	4.6±0.3	4.1±0.3	1.5 Max	1.5±0.3	1.1±0.3	5.2 TYP.	2.5 TYP.	2.0 TYP.
04018	4.6±0.3	4.1±0.3	1.8 Max	2.0±0.3	1.1±0.3	5.2 TYP.	2.5 TYP.	2.0 TYP.
04020	4.6±0.3	4.1±0.3	2.0 Max	2.0±0.3	1.1±0.3	5.2 TYP.	2.5 TYP.	2.3 TYP.
05012	5.7±0.3	5.2±0.3	1.2 Max	2.2±0.3	1.2±0.3	6.0 TYP.	3.0 TYP.	2.7 TYP.
05015	5.7±0.3	5.2±0.3	1.5 Max	2.2±0.3	1.2±0.3	6.0 TYP.	3.0 TYP.	2.7 TYP.
05018	5.7±0.3	5.2±0.3	1.8 Max	2.2±0.3	1.2±0.3	6.0 TYP.	3.0 TYP.	2.7 TYP.
05020	5.7±0.3	5.2±0.3	2.0 Max	2.2±0.3	1.2±0.3	6.0 TYP.	3.0 TYP.	2.7 TYP.
05030	5.7±0.3	5.2±0.3	3.0 Max	2.3±0.3	1.2±0.3	6.0 TYP.	3.0 TYP.	2.7 TYP.
06012	7.3 Max	6.6±0.2	1.2 Max	3.0±0.3	1.6±0.3	8.4 TYP.	3.7 TYP.	3.5 TYP.
06015	7.5 Max	6.6±0.2	1.5 Max	3.0±0.3	1.6±0.3	8.4 TYP.	3.7 TYP.	3.5 TYP.
06018	7.3 Max	6.6±0.2	1.8 Max	3.0±0.3	1.6±0.3	8.4 TYP.	3.7 TYP.	3.5 TYP.
06020	7.3 Max	6.6±0.2	2.0 Max	3.0±0.3	1.6±0.3	8.4 TYP.	3.7 TYP.	3.5 TYP.
06024	7.5 Max	6.6±0.2	2.4 Max	3.0±0.3	1.6±0.3	8.4 TYP.	3.7 TYP.	3.5 TYP.
06030	7.5 Max	6.6±0.2	3.0 Max	3.0±0.3	1.6±0.3	8.4 TYP.	3.7 TYP.	3.5 TYP.
06040	7.5 Max	6.6±0.2	4.0 Max	3.0±0.3	1.6±0.3	8.4 TYP.	3.7 TYP.	3.5 TYP.
06050	7.5 Max	6.6±0.2	5.0 Max	3.0±0.3	1.6±0.3	8.4 TYP.	3.7 TYP.	3.5 TYP.
08030	9.2 Max	8.0±0.3	3.0 Max	3.0±0.5	1.8±0.5	9.8 REF.	4.8 REF.	3.5 REF.
08040	9.2 Max	8.0±0.3	4.0 Max	3.0±0.5	1.8±0.5	9.8 REF.	4.8 REF.	3.5 REF.
08050	9.2 Max	8.0±0.3	5.0 Max	3.0±0.5	1.8±0.5	9.8 REF.	4.8 REF.	3.5 REF.
08060	9.2 Max	8.0±0.3	8.0 Max	3.0±0.5	1.8±0.5	9.8 REF.	4.8 REF.	3.5 REF.
10020	11.5 Max	10.5 Max	2.0 Max	3.0±0.3	2.3±0.5	9.5 TYP.	6.0 TYP.	4.0 TYP.
10030	11.5 Max	10.5 Max	3.0 Max	3.0±0.3	2.3±0.5	9.5 TYP.	6.0 TYP.	4.0 TYP.
10040	11.5 Max	10.5 Max	4.0 Max	3.0±0.3	2.3±0.5	9.5 TYP.	6.0 TYP.	4.0 TYP.
10050	11.5 Max	10.5 Max	5.0 Max	3.0±0.3	2.3±0.5	9.5 TYP.	6.0 TYP.	4.0 TYP.
10060	11.5 Max	10.4 Max	6.0 Max	3.0±0.3	2.0±0.5	9.5 TYP.	6.0 TYP.	4.0 TYP.
10070	11.5 Max	10.4 Max	7.0 Max	3.0±0.3	2.0±0.5	9.5 TYP.	6.0 TYP.	4.0 TYP.
12035	13.7±0.3	12.8±0.3	3.5 Max	3.8±0.2	2.7±0.5	14.6 TYP.	7.4 TYP.	4.8 TYP.
12040	13.7±0.3	12.8±0.3	4.0 Max	3.8±0.2	2.7±0.5	14.6 TYP.	7.4 TYP.	4.8 TYP.
12050	13.7±0.3	12.8±0.3	5.0 Max	3.8±0.2	2.7±0.5	14.6 TYP.	7.4 TYP.	4.8 TYP.
12060	13.7±0.3	12.8±0.3	6.0 Max	3.8±0.2	2.7±0.5	14.6 TYP.	7.4 TYP.	4.8 TYP.
12065	13.7±0.3	12.8±0.3	6.5 Max	3.8±0.2	2.7±0.5	14.6 TYP.	7.4 TYP.	4.8 TYP.



●ELECTRICAL CHARACTERISTICS

Part Number	Inductance (uH)	Tolerance (T)	RDC (mΩ) Typ.	RDC (mΩ) Max.	Isat (A) Typ.	Irms (A) Typ.
WSL201610-R10M	0.10	M	7.0	12.0	8.4	8.0
WSL201610-R15M	0.15	M	8.0	14.0	8.0	7.0
WSL201610-R22M	0.22	M	11.0	18.0	7.5	6.3
WSL201610-R24M	0.24	M	12.0	19.0	7.4	6.2
WSL201610-R33M	0.33	M	17.0	22.0	6.5	5.3
WSL201610-R47M	0.47	M	22.0	25.0	5.5	5.0
WSL201610-R68M	0.68	M	25.0	32.0	4.7	4.3
WSL201610-1R0M	1.00	M	35.0	43.0	4.2	4.1
WSL201610-1R5M	1.50	M	80.0	100.0	2.9	2.3
WSL201610-2R2M	2.20	M	120.0	130.0	2.8	2.1
WSL201610-3R3M	3.30	M	140.0	170.0	2.0	1.5
WSL201610-4R7M	4.70	M	190.0	220.0	1.8	1.4

* Inductance test Freq.: 1MHz/1.0V

* M = Tolerance = ±20%

* The saturation current value (Isat) is the DC current value having inductance decrease 30%. (at 25°C)

* The temperature rise current value (Irms) DC current value having temperature increase up to 40°C

Part Number	Inductance (uH)	Tolerance (T)	RDC (mΩ) Typ.	RDC (mΩ) Max.	Isat (A) Typ.	Irms (A) Typ.
WSL04015-R22M	0.22	M	6.4	7.3	9.0	8.0
WSL04015-R47M	0.47	M	11.0	13.0	7.5	7.0
WSL04015-1R0M	1.00	M	27.0	31.0	6.5	5.0
WSL04015-1R2M	1.20	M	31.0	36.0	5.8	4.5
WSL04015-1R5M	1.50	M	37.0	45.0	5.0	4.0
WSL04015-2R2M	2.20	M	63.0	79.0	4.0	3.5
WSL04015-3R3M	3.30	M	85.0	98.0	3.2	2.8
WSL04015-4R7M	4.70	M	108.0	135.0	3.0	2.0
WSL04015A-4R7M	4.70	M	85.0	108.0	3.8	3.5
WSL04015-100M	10.00	M	225.0	258.0	1.8	1.5

* Inductance test Freq.: 1MHz/1.0V

* M = Tolerance = ±20%

* The saturation current value (Isat) is the DC current value having inductance decrease 30%. (at 25°C)

* The temperature rise current value (Irms) DC current value having temperature increase up to 40°C



Part Number	Inductance (μ H)	Tolerance (T)	RDC ($m\Omega$) Typ.	RDC ($m\Omega$) Max.	Isat (A) Typ.	Irms (A) Typ.
WSL04018-1R0M	1.00	M	27.0	6.0	4.0	27.0
WSL04018-2R2M	2.20	M	49.0	5.0	4.0	49.0
WSL04018-4R7M	4.70	M	139.0	2.5	2.0	139.0
WSL04018-6R8M	6.80	M	148.0	2.5	2.0	148.0
WSL04018-100M	10.00	M	150.0	2.2	1.6	150.0
WSL04018-220M	22.00	M	540.0	1.5	1.5	540.0

* Inductance test Freq.: 1MHz/1.0V

* M = Tolerance = $\pm 20\%$

* The saturation current value (Isat) is the DC current value having inductance decrease 30%. (at 25°C)

* The temperature rise current value (Irms) DC current value having temperature increase up to 40°C

Part Number	Inductance (μ H)	Tolerance (T)	RDC ($m\Omega$) Typ.	RDC ($m\Omega$) Max.	Isat (A) Typ.	Irms (A) Typ.
WSL04020-R10M	0.10	N	3.8	4.2	15.0	14.0
WSL04020-R22M	0.22	M	4.0	6.3	13.0	8.0
WSL04020-R33M	0.33	M	7.2	9.6	11.0	7.0
WSL04020-R47M	0.47	M	10.0	12.0	10.0	6.5
WSL04020-R56M	0.56	M	11.0	14.0	9.0	6.5
WSL04020-R68M	0.68	M	17.0	20.0	8.0	5.0
WSL04020-1R0M	1.00	M	23.0	27.0	7.0	5.0
WSL04020-1R2M	1.20	M	24.0	29.0	6.5	5.0
WSL04020-1R5M	1.50	M	30.0	36.0	6.5	4.5
WSL04020-2R2M	2.20	M	41.0	49.0	5.0	4.0
WSL04020-3R3M	3.30	M	62.0	76.0	4.0	3.5
WSL04020-4R7M	4.70	M	101.0	127.0	3.5	3.0
WSL04020-5R6M	5.60	M	126.0	150.0	3.0	2.5
WSL04020-6R8M	6.80	M	137.0	157.0	2.5	2.2
WSL04020-8R2M	8.20	M	145.0	180.0	2.5	2.0
WSL04020-100M	10.00	M	181.0	243.0	2.0	1.8
WSL04020-150M	15.00	M	280.0	330.0	1.5	1.4
WSL04020-220M	22.00	M	401.0	500.0	1.3	1.2

* Inductance test Freq.: 1MHz/1.0V

* M = Tolerance = $\pm 20\%$, N = Tolerance = $\pm 30\%$

* The saturation current value (Isat) is the DC current value having inductance decrease 30%. (at 25°C)

* The temperature rise current value (Irms) DC current value having temperature increase up to 40°C



Part Number	Inductance (uH)	Tolerance (T)	RDC (mΩ) Typ.	RDC (mΩ) Max.	Isat (A) Typ.	Irms (A) Typ.
WSL05012-R10M	0.10	N	5.1	6.0	9.0	9.0
WSL05012-R33M	0.33	M	7.5	8.5	7.0	7.0
WSL05012-1R0M	1.00	M	26.0	30.0	5.0	4.0
WSL05012-4R7M	4.70	M	158.0	181.0	3.5	3.0

* Inductance test Freq.: 1MHz/1.0V

* M = Tolerance = ±20%, N = Tolerance = ±30%

* The saturation current value (Isat) is the DC current value having inductance decrease 30%. (at 25°C)

* The temperature rise current value (Irms) DC current value having temperature increase up to 40°C

Part Number	Inductance (uH)	Tolerance (T)	RDC (mΩ) Typ.	RDC (mΩ) Max.	Isat (A) Typ.	Irms (A) Typ.
WSL05015-R33M	0.33	M	7.5	8.5	12.0	9.0
WSL05015-1R0M	1.00	M	19.5	27.0	6.0	5.0
WSL05015-1R5M	1.50	M	27.0	35.0	5.2	4.5
WSL05015-2R2M	2.20	M	45.0	55.0	4.0	3.3
WSL05015-4R7M	4.70	M	80.0	115.0	3.5	2.8

* Inductance test Freq.: 1MHz/1.0V

* M = Tolerance = ±20%

* The saturation current value (Isat) is the DC current value having inductance decrease 30%. (at 25°C)

* The temperature rise current value (Irms) DC current value having temperature increase up to 40°C



Part Number	Inductance (μ H)	Tolerance (T)	RDC ($m\Omega$) Typ.	RDC ($m\Omega$) Max.	Isat (A) Typ.	Irms (A) Typ.
WSL05018-R33M	0.33	M	6.3	7.3	13.0	9.0
WSL05018-R47M	0.47	M	10.0	12.0	11.0	8.5
WSL05018-R56M	0.56	M	11.0	13.2	9.8	8.0
WSL05018-R68M	0.68	M	13.3	15.0	9.5	8.0
WSL05018-1R0M	1.00	M	14.3	16.5	7.5	6.0
WSL05018-1R5M	1.50	M	24.0	35.0	6.0	5.0
WSL05018-2R2M	2.20	M	36.0	41.0	5.5	3.5
WSL05018-3R3M	3.20	M	53.0	58.0	5.0	4.0
WSL05018-4R7M	4.70	M	80.1	90.0	4.0	3.0
WSL05018-6R8M	6.80	M	115.0	132.0	3.0	2.5
WSL05018-100M	10.00	M	150.0	155.0	2.0	1.8

* Inductance test Freq.: 1MHz/1.0V

* M = Tolerance = $\pm 20\%$

* The saturation current value (Isat) is the DC current value having inductance decrease 30%. (at 25°C)

* The temperature rise current value (Irms) DC current value having temperature increase up to 40°C



Part Number	Inductance (μ H)	Tolerance (T)	RDC ($m\Omega$) Typ.	RDC ($m\Omega$) Max.	Isat (A) Typ.	Irms (A) Typ.
WSL05020-R12M	0.15	M	3.2	3.7	19.0	20.0
WSL05020-R22M	0.22	M	6.0	6.9	17.0	15.0
WSL05020-R33M	0.33	M	6.3	7.5	13.5	12.5
WSL05020-R47M	0.47	M	8.0	10.0	12.0	11.0
WSL05020-R68M	0.68	M	12.5	13.0	10.0	9.9
WSL05020-1R0M	1.00	M	14.3	16.5	10.0	9.0
WSL05020-1R2M	1.20	M	16.0	19.0	9.0	8.0
WSL05020-1R5M	1.50	M	18.6	22.0	7.5	6.5
WSL05020-2R2M	2.20	M	32.0	37.0	6.5	5.5
WSL05020-3R3M	3.30	M	43.8	51.0	5.0	4.5
WSL05020-4R7M	4.70	M	62.5	81.0	4.5	4.0
WSL05020-6R8M	6.80	M	120.1	139.0	3.0	2.5
WSL05020-8R2M	8.20	M	139.0	161.0	3.0	2.0
WSL05020-100M	10.00	M	164.3	189.0	2.6	1.8
WSL05020-150M	15.00	M	210.6	242.1	2.5	2.0
WSL05020-220M	22.00	M	298.0	381.0	2.0	1.5

* Inductance test Freq.: 1MHz/1.0V

* M = Tolerance = $\pm 20\%$

* The saturation current value (Isat) is the DC current value having inductance decrease 30%. (at 25°C)

* The temperature rise current value (Irms) DC current value having temperature increase up to 40°C



Part Number	Inductance (μ H)	Tolerance (T)	RDC ($m\Omega$) Typ.	RDC ($m\Omega$) Max.	Isat (A) Typ.	Irms (A) Typ.
WSL05030-R15M	0.15	M	2.3	2.7	20.0	23.0
WSL05030-R20M	0.20	M	3.6	4.3	18.0	17.0
WSL05030-R22M	0.22	M	3.5	5.5	17.0	16.0
WSL05030-R33M	0.33	M	6.5	8.0	15.5	15.0
WSL05030-R47M	0.47	M	6.5	8.5	19.0	13.0
WSL05030-R68M	0.68	M	11.0	12.0	11.5	9.9
WSL05030-1R0M	1.00	M	9.6	12.5	9.5	9.0
WSL05030-1R2M	1.20	M	12.0	16.0	9.0	8.0
WSL05030-1R5M	1.50	M	15.0	19.0	9.0	7.5
WSL05030-2R2M	2.20	M	18.7	22.0	7.0	6.5
WSL05030-3R3M	3.30	M	28.6	33.5	6.0	5.5
WSL05030-4R7M	4.70	M	45.6	54.0	5.0	4.5
WSL05030-5R6M	5.60	M	55.0	66.0	4.5	4.0
WSL05030-6R8M	6.80	M	74.0	86.0	4.0	3.5
WSL05030-8R2M	8.20	M	95.0	100.0	3.8	3.2
WSL05030-100M	10.00	M	89.8	104.0	3.5	3.0
WSL05030-150M	15.00	M	189.0	218.0	3.0	2.5
WSL05030-220M	22.00	M	298.0	342.0	2.0	1.5
WSL05030-330M	33.00	M	310.0	341.0	1.6	1.3
WSL05030-470M	47.00	M	379.0	436.0	1.6	1.2
WSL05030-680M	68.00	M	547.0	600.0	1.5	1.2

* Inductance test Freq.: 1MHz/1.0V

* M = Tolerance = $\pm 20\%$

* The saturation current value (Isat) is the DC current value having inductance decrease 30%. (at 25°C)

* The temperature rise current value (Irms) DC current value having temperature increase up to 40°C



Part Number	Inductance (μ H)	Tolerance (T)	RDC ($m\Omega$) Typ.	RDC ($m\Omega$) Max.	Isat (A) Typ.	Irms (A) Typ.
WSL06012-2R2M	2.20	M	80.0	88.0	5.5	3.5
WSL06012-4R7M	4.70	M	135.0	145.0	3.0	1.5
WSL06012-6R8M	6.80	M	168.0	185.0	3.5	2.5
WSL06012-100M	10.00	M	231.0	254.0	2.5	1.8

* Inductance test Freq.: 1MHz/1.0V

* M = Tolerance = $\pm 20\%$

* The saturation current value (Isat) is the DC current value having inductance decrease 30%. (at 25°C)

* The temperature rise current value (Irms) DC current value having temperature increase up to 40°C

Part Number	Inductance (μ H)	Tolerance (T)	RDC ($m\Omega$) Typ.	RDC ($m\Omega$) Max.	Isat (A) Typ.	Irms (A) Typ.
WSL06015-R68M	0.68	M	14.0	17.0	8.0	6.0
WSL06015-1R0M	1.00	M	20.0	25.0	7.0	5.0
WSL06015-1R5M	1.50	M	28.0	32.0	6.0	4.0
WSL06015-4R7M	4.70	M	82.0	98.4	4.0	3.5
WSL06015-6R8M	6.80	M	125.0	135.0	3.0	2.0
WSL06015-100M	10.00	M	170.0	182.0	2.0	1.5

* Inductance test Freq.: 1MHz/1.0V

* M = Tolerance = $\pm 20\%$

* The saturation current value (Isat) is the DC current value having inductance decrease 30%. (at 25°C)

* The temperature rise current value (Irms) DC current value having temperature increase up to 40°C



Part Number	Inductance (μ H)	Tolerance (T)	RDC ($m\Omega$) Typ.	RDC ($m\Omega$) Max.	Isat (A) Typ.	Irms (A) Typ.
WSL06018-R22M	0.22	M	3.6	4.5	15.0	14.0
WSL06018-R47M	0.47	M	6.0	8.0	13.0	12.0
WSL06018-R68M	0.68	M	9.0	10.8	9.0	6.0
WSL06018A-1R0M	1.00	M	15.0	18.3	14.0	7.0
WSL06018-1R0M	1.00	M	15.0	17.0	12.0	5.0
WSL06018-1R5M	1.50	M	24.0	26.0	8.0	6.0
WSL06018A-2R2M	2.20	M	30.0	35.0	10.0	6.0
WSL06018-2R2M	2.20	M	30.0	39.0	6.5	5.0
WSL06018-3R3M	3.30	M	43.0	50.0	5.0	3.0
WSL06018-4R7M	4.70	M	50.0	60.0	0.0	0.0
WSL06018-6R8M	6.80	M	65.0	74.0	4.0	2.5
WSL06018-100M	10.00	M	144.0	173.0	3.0	2.8
WSL06018-220M	22.00	M	330.0	350.0	2.5	1.8

* Inductance test Freq.: 1MHz/1.0V

* M = Tolerance = $\pm 20\%$

* The saturation current value (Isat) is the DC current value having inductance decrease 30%. (at 25°C)

* The temperature rise current value (Irms) DC current value having temperature increase up to 40°C



Part Number	Inductance (μ H)	Tolerance (T)	RDC ($m\Omega$) Typ.	RDC ($m\Omega$) Max.	Isat (A) Typ.	Irms (A) Typ.
WSL06020-R15M	0.15	M	2.1	2.3	20.0	20.0
WSL06020-R22M	0.22	M	3.8	4.3	18.0	15.0
WSL06020-R33M	0.33	M	5.6	6.8	17.0	13.0
WSL06020-R47M	0.47	M	6.7	7.9	16.0	12.0
WSL06020-R68M	0.68	M	6.9	8.2	13.0	11.0
WSL06020-1R0M	1.00	M	11.7	15.2	11.0	6.0
WSL06020-1R5M	1.50	M	20.5	26.6	9.0	5.0
WSL06020-2R2M	2.20	M	27.0	35.1	7.5	4.0
WSL06020-3R3M	3.30	M	43.0	56.0	6.0	3.0
WSL06020-4R7M	4.70	M	56.0	72.0	5.0	3.5
WSL06020-6R8M	6.80	M	99.0	114.0	4.0	3.5
WSL06020-100M	10.00	M	95.0	125.0	3.0	2.5
WSL06020-150M	15.00	M	203.0	259.0	3.0	2.0
WSL06020-220M	22.00	M	256.0	334.0	2.5	2.0

* Inductance test Freq.: 1MHz/1.0V

* M = Tolerance = $\pm 20\%$

* The saturation current value (Isat) is the DC current value having inductance decrease 30%. (at 25°C)

* The temperature rise current value (Irms) DC current value having temperature increase up to 40°C



Part Number	Inductance (μ H)	Tolerance (T)	RDC ($m\Omega$) Typ.	RDC ($m\Omega$) Max.	Isat (A) Typ.	Irms (A) Typ.
WSL06024-R15M	0.15	M	1.0	1.2	20.0	20.0
WSL06024-R22M	0.22	M	3.8	4.3	21.0	18.0
WSL06024-R47M	0.47	M	4.0	5.5	16.0	10.0
WSL06024-R68M	0.68	M	6.0	7.5	14.0	9.0
WSL06024-1R0M	1.00	M	8.5	12.0	13.0	8.0
WSL06024-1R5M	1.50	M	13.0	18.0	12.0	7.0
WSL06024-2R2M	2.20	M	21.0	28.0	10.0	6.0
WSL06024-2R7M	2.70	M	27.0	31.0	7.0	5.0
WSL06024-3R3M	3.30	M	40.0	45.0	8.5	5.0
WSL06024-4R7M	4.70	M	41.0	50.0	8.0	4.5
WSL06024-6R8M	6.80	M	46.0	65.0	6.0	4.0
WSL06024-100M	10.00	M	82.0	106.0	4.0	3.0
WSL06024-150M	15.00	M	131.0	140.0	3.5	2.8
WSL06024-220M	22.00	M	167.0	217.0	3.0	2.5
WSL06024-330M	33.00	M	229.0	263.0	2.0	1.8

* Inductance test Freq.: 1MHz/1.0V

* M = Tolerance = $\pm 20\%$

* The saturation current value (Isat) is the DC current value having inductance decrease 30%. (at 25°C)

* The temperature rise current value (Irms) DC current value having temperature increase up to 40°C



Part Number	Inductance (μ H)	Tolerance (T)	RDC ($m\Omega$) Typ.	RDC ($m\Omega$) Max.	Isat (A) Typ.	Irms (A) Typ.
WSL06030-R10M	0.10	N	0.6	0.7	30.0	28.0
WSL06030-R15M	0.15	M	0.7	1.2	28.0	25.0
WSL06030-R22M	0.22	M	2.5	2.8	26.0	23.0
WSL06030-R33M	0.33	M	2.5	3.0	25.0	21.0
WSL06030-R47M	0.47	M	3.4	4.1	20.0	19.0
WSL06030-R56M	0.56	M	4.8	6.8	19.5	18.0
WSL06030-R68M	0.68	M	4.7	5.4	19.0	17.0
WSL06030-R82M	0.82	M	5.6	7.5	18.0	16.0
WSL06030-1R0M	1.00	M	7.6	9.0	16.5	14.0
WSL06030-1R2M	1.20	M	8.0	10.5	14.0	12.2
WSL06030-1R5M	1.50	M	10.0	13.0	12.0	11.5
WSL06030-2R2M	2.20	M	15.0	18.0	10.0	8.0
WSL06030-2R7M	2.70	M	21.0	25.3	10.0	8.5
WSL06030-3R3M	3.30	M	22.0	30.0	9.5	7.0
WSL06030-4R7M	4.70	M	30.4	35.0	7.0	6.5
WSL06030-5R6M	5.60	M	37.4	42.0	6.0	5.5
WSL06030-6R8M	6.80	M	41.0	50.0	6.0	5.5
WSL06030-8R2M	8.20	M	64.0	68.0	5.5	5.0
WSL06030-100M	10.00	M	60.0	68.0	5.0	4.5
WSL06030-150M	15.00	M	90.0	115.0	4.0	3.5
WSL06030-220M	22.00	M	125.0	145.0	3.2	3.0
WSL06030-330M	33.00	M	220.0	253.0	2.5	2.1
WSL06030-470M	47.00	M	296.0	340.0	2.0	1.8
WSL06030-680M	68.00	M	506.0	581.9	2.0	1.5
WSL06030-101M	100.00	M	825.0	932.0	1.5	1.0

* Inductance test Freq.: 1MHz/1.0V

* M = Tolerance = $\pm 20\%$, N = Tolerance = $\pm 30\%$

* The saturation current value (Isat) is the DC current value having inductance decrease 30%. (at 25°C)

* The temperature rise current value (Irms) DC current value having temperature increase up to 40°C



Part Number	Inductance (μ H)	Tolerance (T)	RDC ($m\Omega$) Typ.	RDC ($m\Omega$) Max.	Isat (A) Typ.	Irms (A) Typ.
WSL06040-R10M	0.10	M	0.4	0.6	30.0	37.0
WSL06040-R15M	0.15	M	0.9	1.0	28.0	25.0
WSL06040-1R0M	1.00	M	6.1	6.8	17.0	14.5
WSL06040-1R5M	1.50	M	7.7	8.9	14.0	12.0
WSL06040-2R2M	2.20	M	9.2	10.6	11.0	9.0
WSL06040-3R3M	3.30	M	16.0	18.4	10.0	8.0
WSL06040-4R7M	4.70	M	25.0	30.0	8.5	7.0
WSL06040-6R8M	6.80	M	34.0	39.1	7.0	5.8
WSL06040-100M	10.00	M	50.0	57.5	6.0	5.0
WSL06040-150M	15.00	M	67.0	77.0	5.0	4.3
WSL06040-220M	22.00	M	120.0	138.0	3.5	3.0
WSL06040-330M	33.00	M	214.0	246.0	3.0	2.3
WSL06040-470M	47.00	M	258.0	297.0	2.5	1.8

* Inductance test Freq.: 1MHz/1.0V

* M = Tolerance = $\pm 20\%$

* The saturation current value (Isat) is the DC current value having inductance decrease 30%. (at 25°C)

* The temperature rise current value (Irms) DC current value having temperature increase up to 40°C



Part Number	Inductance (μ H)	Tolerance (T)	RDC ($m\Omega$) Typ.	RDC ($m\Omega$) Max.	Isat (A) Typ.	Irms (A) Typ.
WSL06050-R15M	0.15	M	0.9	1.3	32.0	36.0
WSL06050-R22M	0.22	M	1.5	2.1	30.0	28.0
WSL06050-R33M	0.33	M	2.2	2.7	24.0	21.5
WSL06050-R56M	0.56	M	3.4	3.6	22.0	20.0
WSL06050-R68M	0.68	M	4.2	4.5	20.0	18.0
WSL06050-R82M	0.82	M	4.5	6.0	17.0	16.0
WSL06050-1R0M	1.00	M	5.6	7.0	13.0	15.0
WSL06050-1R5M	1.50	M	7.0	10.0	11.5	10.0
WSL06050-2R2M	2.20	M	9.8	12.0	11.0	9.0
WSL06050-3R3M	3.30	M	13.0	16.0	9.0	8.0
WSL06050-4R7M	4.70	M	19.4	25.5	8.0	7.0
WSL06050-5R6M	5.60	M	22.0	28.0	7.0	6.5
WSL06050-6R8M	6.80	M	22.0	30.0	6.5	6.0
WSL06050-8R2M	8.20	M	40.4	47.5	7.0	6.3
WSL06050-8R5M	8.50	M	30.0	35.8	4.5	4.0
WSL06050-100M	10.00	M	40.4	47.5	6.5	6.0
WSL06050-150M	15.00	M	54.0	70.0	5.5	5.0
WSL06050-180M	18.00	M	82.0	95.0	5.0	4.5
WSL06050-220M	22.00	M	89.5	103.0	4.5	4.0
WSL06050-330M	33.00	M	147.0	170.0	3.2	2.0
WSL06050-470M	47.00	M	198.0	210.0	2.5	2.0
WSL06050-560M	56.00	M	266.0	290.0	1.8	1.2
WSL06050-680M	68.00	M	342.0	360.0	2.1	2.0
WSL06050-820M	82.00	M	440.0	484.0	2.0	1.5
WSL06050-101M	100.00	M	469.0	612.0	2.0	1.8
WSL06050-151M	150.00	M	890.0	950.0	1.2	0.7

* Inductance test Freq.: 1MHz/1.0V

* M = Tolerance = $\pm 20\%$

* The saturation current value (Isat) is the DC current value having inductance decrease 30%. (at 25°C)

* The temperature rise current value (Irms) DC current value having temperature increase up to 40°C



Part Number	Inductance (uH)	Tolerance (T)	RDC (mΩ) Typ.	RDC (mΩ) Max.	Isat (A) Typ.	Irms (A) Typ.
WSL08030-1R0M	1.00	M	5.0	8.4	18.0	16.0
WSL08030-2R2M	2.20	M	14.0	17.0	12.0	10.0
WSL08030-3R3M	3.30	M	15.0	19.0	8.0	6.0
WSL08030-4R7M	4.70	M	26.0	29.0	7.0	5.0

* Inductance test Freq.: 1MHz/1.0V

* M = Tolerance = ±20%

* The saturation current value (Isat) is the DC current value having inductance decrease 30%. (at 25°C)

* The temperature rise current value (Irms) DC current value having temperature increase up to 40°C

Part Number	Inductance (uH)	Tolerance (T)	RDC (mΩ) Typ.	RDC (mΩ) Max.	Isat (A) Typ.	Irms (A) Typ.
WSL08040-2R2M	2.20	M	7.0	10.0	14.0	12.0
WSL08040-3R3M	3.30	M	15.0	18.0	13.0	11.0
WSL08040-4R7M	4.70	M	20.0	25.0	11.0	9.0
WSL08040-6R8M	6.80	M	22.0	26.0	8.0	6.0
WSL08040-8R2M	8.20	M	27.0	32.0	7.0	5.5
WSL08040-100M	10.00	M	32.0	38.0	6.3	4.0
WSL08040-220M	22.00	M	92.0	98.5	4.2	3.6

* Inductance test Freq.: 1MHz/1.0V

* M = Tolerance = ±20%

* The saturation current value (Isat) is the DC current value having inductance decrease 30%. (at 25°C)

* The temperature rise current value (Irms) DC current value having temperature increase up to 40°C



Part Number	Inductance (μ H)	Tolerance (T)	RDC ($m\Omega$) Typ.	RDC ($m\Omega$) Max.	Isat (A) Typ.	Irms (A) Typ.
WSL08050-R68M	0.68	M	3.4	4.5	26.0	20.0
WSL08050-1R5M	1.50	M	6.5	7.0	17.0	16.0
WSL08050-2R2M	2.20	M	6.5	9.0	15.0	14.0
WSL08050-3R3M	3.30	M	10.0	12.0	13.0	8.8
WSL08050-4R7M	4.70	M	16.0	19.0	11.0	10.0
WSL08050-6R8M	6.80	M	18.0	22.0	10.0	9.0
WSL08050-100M	10.00	M	26.0	30.0	8.0	7.0
WSL08050-150M	15.00	M	55.0	65.0	6.0	5.0
WSL08050-220M	22.00	M	72.0	80.0	5.0	4.0
WSL08050-270M	27.00	M	140.0	182.0	4.5	3.0
WSL08050-330M	33.00	M	112.0	130.0	4.0	2.0
WSL08050-470M	47.00	M	206.0	247.0	3.2	2.0
WSL08050-560M	56.00	M	200.0	250.0	3.0	1.8
WSL08050-680M	68.00	M	230.0	270.0	2.8	1.6

* Inductance test Freq.: 1MHz/1.0V

* M = Tolerance = $\pm 20\%$

* The saturation current value (Isat) is the DC current value having inductance decrease 30%. (at 25°C)

* The temperature rise current value (Irms) DC current value having temperature increase up to 40°C

Part Number	Inductance (μ H)	Tolerance (T)	RDC ($m\Omega$) Typ.	RDC ($m\Omega$) Max.	Isat (A) Typ.	Irms (A) Typ.
WSL08060-4R7M	4.70	M	13.0	16.0	12.0	10.0
WSL08060-150M	15.00	M	35.0	42.0	6.0	5.0
WSL08060-220M	22.00	M	55.0	58.0	6.0	5.0
WSL08060-330M	33.00	M	92.0	102.0	4.5	3.5

* Inductance test Freq.: 1MHz/1.0V

* M = Tolerance = $\pm 20\%$

* The saturation current value (Isat) is the DC current value having inductance decrease 30%. (at 25°C)

* The temperature rise current value (Irms) DC current value having temperature increase up to 40°C



Part Number	Inductance (uH)	Tolerance (T)	RDC (mΩ) Typ.	RDC (mΩ) Max.	Isat (A) Typ.	Irms (A) Typ.
WSL10020-1R0M	1.00	M	12.0	14.5	15.0	10.5
WSL10020-2R2M	2.20	M	20.0	25.0	10.0	8.0
WSL10020-4R7M	4.70	M	45.0	54.0	8.5	7.0
WSL10020-6R8M	6.80	M	54.0	61.0	5.5	4.0
WSL10020-8R2M	8.20	M	54.0	61.0	7.5	6.0
WSL10020-100M	10.00	M	68.0	72.0	4.0	3.0

* Inductance test Freq.: 1MHz/1.0V

* M = Tolerance = ±20%

* The saturation current value (Isat) is the DC current value having inductance decrease 30%. (at 25°C)

* The temperature rise current value (Irms) DC current value having temperature increase up to 40°C

Part Number	Inductance (uH)	Tolerance (T)	RDC (mΩ) Typ.	RDC (mΩ) Max.	Isat (A) Typ.	Irms (A) Typ.
WSL10030-R15M	0.15	M	0.9	1.1	38.0	30.0
WSL10030-R22M	0.22	M	1.2	1.5	36.0	30.0
WSL10030-R33M	0.33	M	1.6	1.9	32.0	23.0
WSL10030-R36M	0.36	M	1.7	2.1	30.0	25.0
WSL10030-R47M	0.47	M	1.8	2.2	24.0	23.0
WSL10030-1R0M	1.00	M	4.1	6.0	20.0	15.0
WSL10030-1R5M	1.50	M	7.6	10.0	19.0	16.0
WSL10030-2R2M	2.20	M	10.0	12.0	13.0	12.0
WSL10030-3R3M	3.30	M	16.0	19.0	14.0	8.0
WSL10030-4R7M	4.70	M	23.0	27.0	9.5	8.0
WSL10030-6R8M	6.80	M	26.0	33.0	8.0	7.0
WSL10030-100M	10.00	M	59.0	67.3	7.5	6.0
WSL10030-150M	15.00	M	75.0	86.3	5.2	4.5
WSL10030-220M	22.00	M	109.0	125.4	4.5	4.0
WSL10030-330M	33.00	M	135.0	173.0	3.0	2.5

* Inductance test Freq.: 1MHz/1.0V

* M = Tolerance = ±20%

* The saturation current value (Isat) is the DC current value having inductance decrease 30%. (at 25°C)

* The temperature rise current value (Irms) DC current value having temperature increase up to 40°C



Part Number	Inductance (μ H)	Tolerance (T)	RDC ($m\Omega$) Typ.	RDC ($m\Omega$) Max.	Isat (A) Typ.	Irms (A) Typ.
WSL10040-R15M	0.15	M	0.6	0.7	60.0	45.0
WSL10040-R20M	0.20	M	0.6	0.8	60.0	35.0
WSL10040-R22M	0.22	M	0.6	0.8	60.0	35.0
WSL10040-R30M	0.30	M	0.8	1.0	42.0	38.0
WSL10040-R33M	0.33	M	0.9	1.0	45.0	35.0
WSL10040-R36M	0.36	M	1.1	1.3	38.0	35.0
WSL10040-R47M	0.47	M	2.3	3.0	35.0	30.0
WSL10040-R56M	0.56	M	1.8	2.0	30.0	25.5
WSL10040-R68M	0.68	M	1.8	2.4	29.0	25.0
WSL10040-R80M	0.80	M	2.5	3.0	25.0	20.0
WSL10040-1R0M	1.00	M	3.5	4.2	23.0	18.0
WSL10040-1R5M	1.50	M	4.6	5.3	22.0	15.0
WSL10040-2R2M	2.20	M	5.8	7.6	17.0	14.0
WSL10040-3R3M	3.30	M	9.0	12.0	15.0	13.0
WSL10040-4R7M	4.70	M	13.0	15.5	13.0	9.0
WSL10040-5R6M	5.60	M	16.0	23.0	11.5	8.2
WSL10040-6R8M	6.80	M	19.8	23.0	11.0	7.8
WSL10040-8R2M	8.20	M	27.0	31.0	9.0	7.5
WSL10040-100M	10.00	M	31.0	36.0	9.0	7.2
WSL10040-150M	15.00	M	48.5	56.0	6.5	5.5
WSL10040-220M	22.00	M	52.0	68.5	6.0	5.1
WSL10040-330M	33.00	M	86.0	98.0	5.0	4.0
WSL10040-470M	47.00	M	131.0	150.0	4.0	3.0
WSL10040-680M	68.00	M	213.0	240.0	3.5	2.9
WSL10040-101M	100.00	M	330.0	370.0	2.0	1.8
WSL10040-151M	150.00	M	376.0	481.0	2.0	1.5

* Inductance test Freq.: 1MHz/1.0V

* M = Tolerance = $\pm 20\%$

* The saturation current value (Isat) is the DC current value having inductance decrease 30%. (at 25°C)

* The temperature rise current value (Irms) DC current value having temperature increase up to 40°C



Part Number	Inductance (μ H)	Tolerance (T)	RDC ($m\Omega$) Typ.	RDC ($m\Omega$) Max.	Isat (A) Typ.	Irms (A) Typ.
WSL10050-R22M	0.22	M	0.6	0.8	45.0	38.0
WSL10050-R33M	0.33	M	0.9	1.2	40.0	35.0
WSL10050-R47M	0.47	M	1.0	1.3	38.0	35.0
WSL10050-R68M	0.68	M	1.3	1.5	35.0	28.0
WSL10050-1R0M	1.00	M	2.1	2.4	25.0	22.0
WSL10050-1R5M	1.50	M	3.4	4.4	24.0	20.0
WSL10050-1R8M	1.80	M	4.2	4.6	23.0	20.0
WSL10050-2R2M	2.20	M	5.9	6.8	21.5	18.0
WSL10050-3R3M	3.30	M	7.0	8.1	20.0	15.0
WSL10050-4R7M	4.70	M	11.0	14.0	14.0	12.0
WSL10050-5R6M	5.60	M	15.0	18.0	14.0	11.0
WSL10050-6R8M	6.80	M	15.3	19.2	12.5	11.0
WSL10050-8R2M	8.20	M	22.0	25.0	12.5	9.0
WSL10050-100M	10.00	M	23.0	28.0	10.5	8.0
WSL10050-150M	15.00	M	34.0	42.0	8.0	7.0
WSL10050-220M	22.00	M	58.0	66.0	7.0	6.0
WSL10050-330M	33.00	M	72.0	90.0	6.0	5.0
WSL10050-470M	47.00	M	105.0	126.0	5.2	4.0
WSL10050-680M	68.00	M	159.0	201.7	4.0	3.0
WSL10050-101M	100.00	M	233.0	274.0	3.5	2.0
WSL10050-151M	150.00	M	377.0	415.0	3.0	2.0
WSL10050-221M	220.00	M	450.0	490.0	1.5	1.2

* Inductance test Freq.: 1MHz/1.0V

* M = Tolerance = $\pm 20\%$

* The saturation current value (Isat) is the DC current value having inductance decrease 30%. (at 25°C)

* The temperature rise current value (Irms) DC current value having temperature increase up to 40°C



Part Number	Inductance (μ H)	Tolerance (T)	RDC ($m\Omega$) Typ.	RDC ($m\Omega$) Max.	Isat (A) Typ.	Irms (A) Typ.
WSL10060-4R7M	4.70	M	9.0	14.0	15.0	13.0
WSL10060-100M	10.00	M	25.0	28.0	13.0	10.0
WSL10060-220M	22.00	M	44.0	50.0	9.0	6.5

* Inductance test Freq.: 1MHz/1.0V

* M = Tolerance = $\pm 20\%$

* The saturation current value (Isat) is the DC current value having inductance decrease 30%. (at 25°C)

* The temperature rise current value (Irms) DC current value having temperature increase up to 40°C

Part Number	Inductance (μ H)	Tolerance (T)	RDC ($m\Omega$) Typ.	RDC ($m\Omega$) Max.	Isat (A) Typ.	Irms (A) Typ.
WSL10070-220M	22.00	M	35.0	38.0	9.0	7.0

* Inductance test Freq.: 1MHz/1.0V

* M = Tolerance = $\pm 20\%$

* The saturation current value (Isat) is the DC current value having inductance decrease 30%. (at 25°C)

* The temperature rise current value (Irms) DC current value having temperature increase up to 40°C

Part Number	Inductance (μ H)	Tolerance (T)	RDC ($m\Omega$) Typ.	RDC ($m\Omega$) Max.	Isat (A) Typ.	Irms (A) Typ.
WSL12035-R22M	0.22	M	0.8	0.9	55.0	40.0
WSL12035-R33M	0.33	M	1.1	1.3	44.0	35.0
WSL12035-R68M	0.68	M	1.9	2.2	40.0	28.0
WSL12035-2R2M	2.20	M	6.4	9.5	20.0	16.0
WSL12035-100M	10.00	M	26.0	30.0	8.0	9.0
WSL12035-330M	33.00	M	81.0	95.0	5.0	5.0

* Inductance test Freq.: 1MHz/1.0V

* M = Tolerance = $\pm 20\%$

* The saturation current value (Isat) is the DC current value having inductance decrease 30%. (at 25°C)

* The temperature rise current value (Irms) DC current value having temperature increase up to 40°C



Part Number	Inductance (uH)	Tolerance (T)	RDC (mΩ) Typ.	RDC (mΩ) Max.	Isat (A) Typ.	Irms (A) Typ.
WSL12040-3R3M	3.30	M	8.0	10.0	18.0	16.0
WSL12040-4R7M	4.70	M	13.0	15.0	13.5	12.0
WSL12040-6R8M	6.80	M	20.0	24.0	11.5	10.0
WSL12040-100M	10.00	M	22.0	25.0	12.0	10.0
WSL12040-120M	12.00	M	25.0	30.0	10.0	8.0

* Inductance test Freq.: 1MHz/1.0V

* M = Tolerance = ±20%

* The saturation current value (Isat) is the DC current value having inductance decrease 30%. (at 25°C)

* The temperature rise current value (Irms) DC current value having temperature increase up to 40°C

Part Number	Inductance (uH)	Tolerance (T)	RDC (mΩ) Typ.	RDC (mΩ) Max.	Isat (A) Typ.	Irms (A) Typ.
WSL12050-R22M	0.22	M	0.5	0.7	60.0	38.0
WSL12050-R47M	0.47	M	1.0	1.5	60.0	36.0
WSL12050-R56M	0.56	M	1.0	1.5	50.0	35.0
WSL12050-R68M	0.68	M	1.1	1.6	30.0	30.0
WSL12050-1R0M	1.00	M	1.8	2.2	28.0	24.0
WSL12050-1R2M	1.20	M	2.0	3.1	28.0	24.0
WSL12050-1R5M	1.50	M	1.9	3.2	28.0	24.0
WSL12050-2R2M	2.20	M	4.0	4.5	25.0	21.0
WSL12050-3R3M	3.30	M	5.0	7.0	21.0	18.0
WSL12050-3R9M	3.90	M	7.0	9.0	20.0	16.0
WSL12050-4R7M	4.70	M	8.9	11.0	21.0	14.0
WSL12050-5R6M	5.60	M	11.5	13.5	17.0	13.0
WSL12050-6R8M	6.80	M	13.0	15.0	16.0	12.0
WSL12050-8R2M	8.20	M	15.0	22.0	14.0	10.0
WSL12050-100M	10.00	M	16.0	22.0	13.0	9.0
WSL12050-150M	15.00	M	25.0	30.0	11.0	9.0
WSL12050-220M	22.00	M	33.0	55.0	8.5	7.0
WSL12050-270M	27.00	M	50.0	68.0	7.0	6.0
WSL12050-330M	33.00	M	65.0	84.0	8.0	5.0
WSL12050-470M	47.00	M	81.0	93.0	5.5	4.5
WSL12050-560M	56.00	M	102.0	117.0	5.5	4.0

* Inductance test Freq.: 1MHz/1.0V

* M = Tolerance = ±20%

* The saturation current value (Isat) is the DC current value having inductance decrease 30%. (at 25°C)

* The temperature rise current value (Irms) DC current value having temperature increase up to 40°C



Part Number	Inductance (μ H)	Tolerance (T)	RDC ($m\Omega$) Typ.	RDC ($m\Omega$) Max.	Isat (A) Typ.	Irms (A) Typ.
WSL12060-2R2M	2.20	M	2.6	4.3	23.0	19.0
WSL12060-3R3M	3.30	M	4.0	5.3	21.0	19.0
WSL12060-4R7M	4.70	M	8.6	9.6	21.0	17.0
WSL12060-6R8M	6.80	M	10.0	12.0	20.0	13.0
WSL12060-100M	10.00	M	20.0	25.0	14.0	11.0
WSL12060-150M	15.00	M	21.0	30.0	12.0	10.0
WSL12060-180M	18.00	M	31.0	34.0	11.0	8.0
WSL12060-220M	22.00	M	36.0	42.0	10.0	7.0
WSL12060-330M	33.00	M	51.0	59.0	7.0	6.0
WSL12060-470M	47.00	M	63.0	75.0	6.5	5.5
WSL12060-560M	56.00	M	78.0	90.0	6.5	4.5
WSL12060-680M	68.00	M	87.0	103.0	5.2	4.5
WSL12060-820M	82.00	M	110.0	140.0	4.5	3.8
WSL12060-101M	100.00	M	125.0	145.0	4.5	3.8
WSL12060-121M	120.00	M	175.0	235.0	4.5	3.2
WSL12060-151M	150.00	M	192.0	230.0	3.5	3.0

* Inductance test Freq.: 1MHz/1.0V

* M = Tolerance = $\pm 20\%$

* The saturation current value (Isat) is the DC current value having inductance decrease 30%. (at 25°C)

* The temperature rise current value (Irms) DC current value having temperature increase up to 40°C



Part Number	Inductance (μ H)	Tolerance (T)	RDC ($m\Omega$) Typ.	RDC ($m\Omega$) Max.	Isat (A) Typ.	Irms (A) Typ.
WSL12065-R22M	0.22	M	0.7	1.0	52.0	40.0
WSL12065-R33M	0.33	M	0.8	1.1	50.0	38.0
WSL12065-R47M	0.47	M	0.9	1.2	48.0	37.0
WSL12065-R56M	0.56	M	1.0	1.4	46.0	36.0
WSL12065-R68M	0.68	M	1.2	1.6	40.0	30.0
WSL12065-R82M	0.82	M	1.3	1.8	38.0	29.0
WSL12065-1R0M	1.00	M	1.6	2.0	42.0	29.0
WSL12065-1R5M	1.50	M	2.4	3.2	32.0	25.0
WSL12065-2R2M	2.20	M	2.8	3.5	26.0	24.0
WSL12065-3R3M	3.30	M	4.8	5.3	23.0	19.0
WSL12065-4R7M	4.70	M	7.5	8.6	23.0	17.0
WSL12065-5R6M	5.60	M	9.2	11.0	18.0	15.0
WSL12065-6R8M	6.80	M	10.5	12.1	16.0	13.0
WSL12065-8R2M	8.20	M	11.0	18.0	15.0	12.0
WSL12065-100M	10.00	M	16.0	20.0	13.0	11.0
WSL12065-150M	15.00	M	22.0	30.0	12.0	10.0
WSL12065-220M	22.00	M	32.0	45.0	10.0	6.5
WSL12065-330M	33.00	M	45.0	59.0	7.0	6.0
WSL12065-470M	47.00	M	63.0	75.0	7.0	6.0
WSL12065-560M	56.00	M	80.0	95.0	6.0	5.0
WSL12065-680M	68.00	M	85.0	103.0	5.5	4.5
WSL12065-820M	82.00	M	96.0	140.0	4.5	4.0
WSL12065-101M	100.00	M	105.0	145.0	4.5	4.0
WSL12065-151M	150.00	M	180.0	220.0	4.0	3.5

* Inductance test Freq.: 1MHz/1.0V

* M = Tolerance = $\pm 20\%$

* The saturation current value (Isat) is the DC current value having inductance decrease 30%. (at 25°C)

* The temperature rise current value (Irms) DC current value having temperature increase up to 40°C



● **RELIABILITY**

Test Item	Test Condition		Specification
Dimension	Actual Size ...		Meet Spec
Solder Heat Resistance	Preheat: 150°C 100s MAX. Solder temperature: 255±5°C DIP time: 10s Max.		1. Inductors should have no evidence of electrical and mechanical damage 2. Inductance should not change more than ± 10%
Vibration Test (LOW Frequency)	1. Amplitude: 1.5mm. 2. Frequency: 10-55-10HZ/1MIN. 3. Direction: X, Y, Z. 4. Duration: 2HRS/X, Y, Z.		
Shock Test	Inductors should be dropped 10 Times. From a height of 1m onto 3cm wooden board.		
Solderability Test	Preheat: 150°C 120 MAX. Solder bath at 255±5°C. DIP time: 10s Max.		More than 90% of terminal electrode should be covered with solder.
Component Adhesion (Push Test)	The device should be reflow soldered (255±5°C for 10 seconds) to a tinned copper substrate. A dynamometer force gauge should be applied to the side of the component. The device must withstand a minimum force of 1.5kg without failure of the termination.		1.5Kg Min
Component Adhesion (Pull Test)	1. Insert 10cm wire into the remaining open eye bend the ends of even wire lengths upward and wind together. 2. Terminal shall not be remarkably damaged.		1.5Kg Min

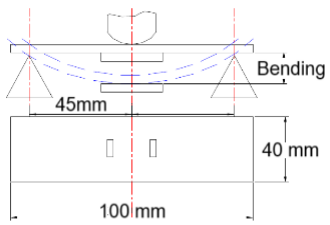

Flexure Strength	Solder a chip on a test substrate, bend the substrate by 2mm and return.		The forces applied should not damage the dielectric.
Resistance To Solvent Test	Inductors shall withstand 6 minutes of alcohol.		There should be no case deformation change in appearance or bite ration of marking
<p>Test conditions: The sample shall be reflow soldered onto the printed circuit board in every test.</p>			

•TEST EQUIPMENT

HP4284 AHP4285A METER LCD &DCR&Q&IDC&SRF

•OPERATING & STORAGE CONDITION

1. Operating Temp: -40°C ~ +125°C (Including self - temperature rise)
2. Storage Temp: a. Product with Taping: -10 ~ 45°C, 50 ~ 60% RH
b. On Board: -55°C ~ +125°C
3. Storage Life Time: 12 Month (Less than 40°C and 60% RH)

Standard Atmosphere Conditions:

Ambient Temperature 20 ± 15°C; Humidity RH 65 ± 20%

If there may be any doubt on the test result, Measurement shall be made within the following limits:

Ambient Temperature 25 ± 5°C; Humidity RH 75 ± 10%



●RECOMMEND REFLOW CURVE (TIME: Second)

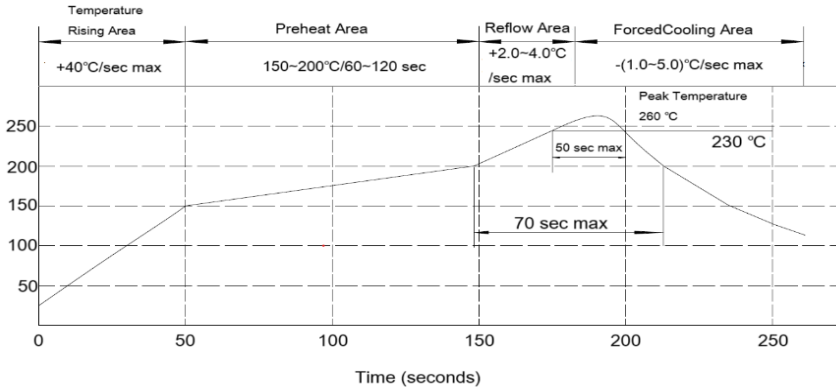

Peak Temperature :260°C max.

Max time above 230°C: 50 sec max.

Max time above 200°C: 70 sec max.

●ATTENTION & CAUTION

- * Keep out of Splashing water or salt water
- * Avoid Toxic Gas (Hydrogen sulfide, Sulfurous acid, Chlorine, Ammonia)
- * Vibrations or shocks which exceed the specified condition
- * Dew condenses
- * Layout near the edge of PCB
- * Over flexure after SMT mounting & PCBA
- * Pin foot or SMD pad solder ability: Pb free type is best within 6 months after delivery
- * Humidity sensitive, IPC/JEDEC J-STD-020 MSL if over Level 1, recommend bake 30mins@150°C before PCBA
- * Caution for human life relative applications: PLS contact & consult with AiT team in design stage.

Care Note for Use:

- (1) Storage Condition:
Temperature 25 to 35°C, Humidity 45 to 60% RH
- (2) Use Temperature:
 - a. Minimum Temperature: -40°C Ambient temperature of this product.
 - b. Maximum Temperature: +125°C The value of temperature including ambient and temperature rise of this product.
 - c. Reliability test temperature range from -40 ~ +125°C
 - d. However, this is not meant as temperature grade guarantee for UL.
- (3) Model:
When this product was used in a similar or as new product to the original one, sometimes it might be unable to satisfy the specifications due to difference in condition of usage.



(4) Drop:

If this product suffered mechanical stress such as drop, characteristics may become poor (due to damage on coil / bobbin / ferrite ... etc.)

Never use such stressed product.

Care Note for Safety:

(1) Provision to Abnormal Condition:

This product itself does not have any protective function in abnormal condition such as overload, short-circuit and open-circuit conditions, etc.

Therefore, it shall be confirmed from the end product that there is no risk of smoking, fire, dielectric withstand voltage insulation resistance, etc. in abnormal conditions to provide protective devices and /or protection circuit in the end product.

(2) Temperature Rise:

Temperature rise on this product depends on the installation condition on end products.

It shall be confirmed on the actual end product that temperature rise of this product is within the specified temperature class limit.

(3) Dielectric Strength:

Dielectric withstanding test with higher voltage than specific value will damage insulating material and shorten its life.

(4) Water:

This product must not be used in wet condition resulted from water, coffee or any liquid contact because insulation strength becomes very low under such condition.

(5) Potting:

If this product is potted in some compound, coating material of magnet wire might be occasionally damaged. Please ask us if you intend to pot this product.

(6) Detergent:

Please consult AiT Semi immediately once under such circumstances because product reliability confirmation etc. is needed when this product come in contact with these chemicals.



●TAPE DIMENSION: mm

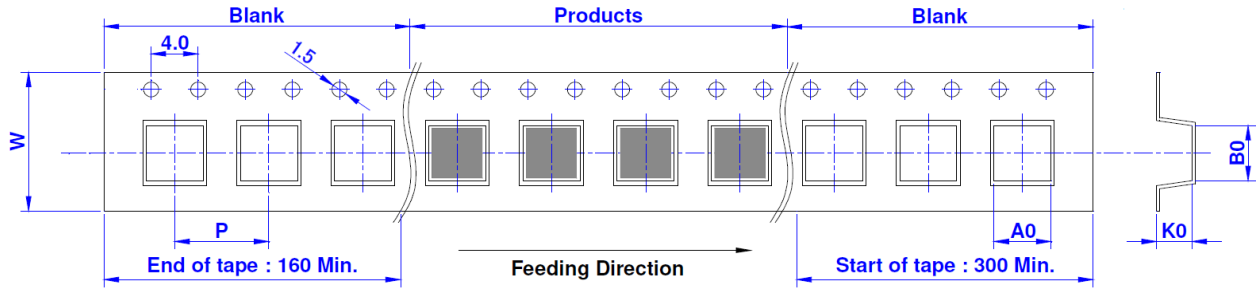

SIZE/mm	W	P	A0	B0	K0
201610	8	4	2	2.5	1.2
04015	12	8	4.6	5.0	1.8
04018	12	8	4.6	5.0	2.2
04020	12	8	4.6	5.0	2.2
05012	12	8	5.9	6.2	1.5
05015	12	8	5.9	6.2	1.8
05018	12	8	5.9	6.2	2.4
05020	12	8	5.9	6.2	2.4
05030	12	8	5.9	6.2	3.4
06012	16	12	10.6	11.7	1.8
06015	16	12	10.6	11.7	2.2
06018	16	12	10.6	11.7	2.2
06020	16	12	10.6	11.7	2.2
06024	16	12	10.6	11.7	2.9
06030	16	12	6.9	7.6	3.4
06040	16	12	6.9	7.6	5.4
06050	16	12	6.9	7.6	5.4
08030	24	16	8.5	9.5	4.3
08040	24	16	8.5	9.5	4.3
08050	24	16	8.5	9.5	5.3
08060	24	16	8.5	9.5	6.3
10020	24	16	10.6	11.7	2.4
10030	24	16	10.6	11.7	4.3
10040	24	16	10.6	11.7	4.3
10050	24	16	10.6	11.7	5.3
10060	24	16	10.6	11.7	6.25
10070	24	16	10.6	11.7	7.25
12035	24	16	13	14	6.75
12040	24	16	13	14	6.75
12050	24	16	13	14	6.75
12060	24	16	13	14	6.75
12065	24	16	13	14	6.75



REEL DIMENSION: mm

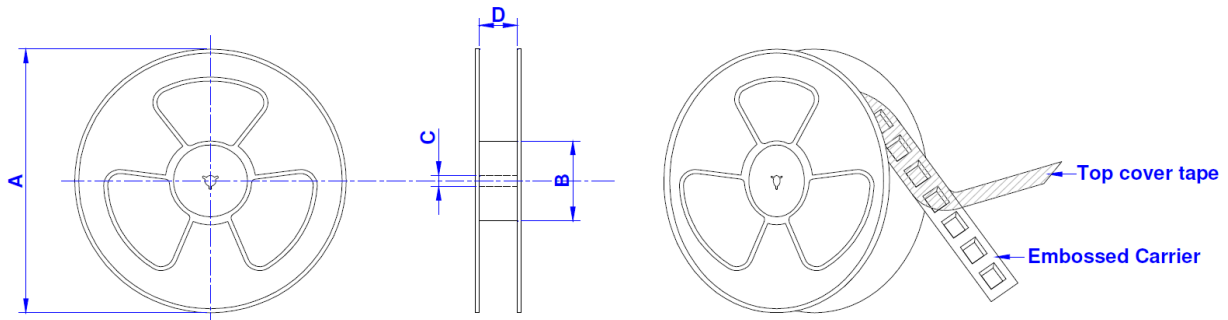

Size / mm	Reel Size	A	B	C	D	QTY / Reel
201610	7" x 8 mm	178	60	13	8.5	3000 PCS
04015	13" x 12 mm	330	100	13	13.4	3000 PCS
04018	13" x 12 mm	330	100	13	13.4	3000 PCS
04020	13" x 12 mm	330	100	13	13.4	3000 PCS
05012	13" x 12 mm	330	100	13	13.4	3000 PCS
05015	13" x 12 mm	330	100	13	13.4	3000 PCS
05018	13" x 12 mm	330	100	13	13.4	3000 PCS
05020	13" x 12 mm	330	100	13	13.4	3000 PCS
05030	13" x 12 mm	330	100	13	13.4	2000 PCS
06012	13" x 12 mm	330	100	13	16.0	2000 PCS
06015	13" x 12 mm	330	100	13	16.0	2000 PCS
06018	13" x 12 mm	330	100	13	16.0	2000 PCS
06020	13" x 12 mm	330	100	13	16.0	2000 PCS
06024	13" x 12 mm	330	100	13	16.0	2000 PCS
06030	13" x 12 mm	330	100	13	16.0	1000 PCS
06040	13" x 12 mm	330	100	13	16.0	1000 PCS
06050	13" x 12 mm	330	100	13	16.0	1000 PCS
08030	13" x 12 mm	330	100	13	24.4	1000 PCS
08040	13" x 12 mm	330	100	13	24.4	1000 PCS
08050	13" x 12 mm	330	100	13	24.4	1000 PCS
08060	13" x 12 mm	330	100	13	24.4	800 PCS
10020	13" x 12 mm	330	100	13	24.4	1000 PCS
10030	13" x 12 mm	330	100	13	24.4	1000 PCS
10040	13" x 12 mm	330	100	13	24.4	1000 PCS
10050	13" x 12 mm	330	100	13	24.4	800 PCS
10060	13" x 12 mm	330	100	13	24.4	500 PCS
10070	13" x 12 mm	330	100	13	24.4	500 PCS
12035	13" x 12 mm	330	100	13	24.4	500 PCS
12040	13" x 12 mm	330	100	13	24.4	500 PCS
12050	13" x 12 mm	330	100	13	24.4	500 PCS
12060	13" x 12 mm	330	100	13	24.4	500 PCS
12065	13" x 12 mm	330	100	13	24.4	500 PCS



●TEARING OFF FORCE :

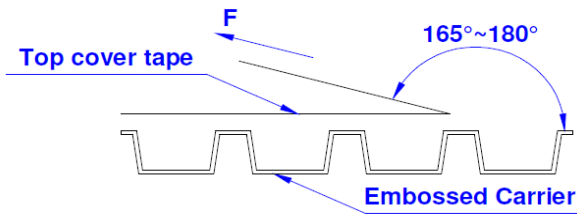

The force for tearing off cover tape is 20 to 120 grams in the arrow direction under the following conditions (referenced ANSI/EIA - 481 - D - 2008 of 4.11 standard).

Room Temp. (°C)	Room Humidity (%)	Room Atm. (hPa)	Tearing Speed (mm/min)
5 ~ 35	45 ~ 85	860~1060	330

●BOX PACKAGE: cm

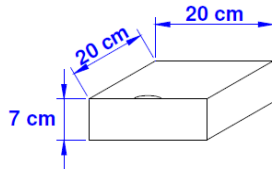

7" Small Box

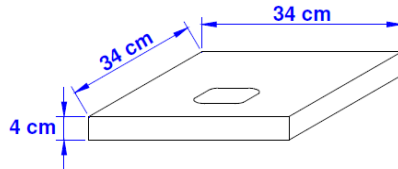

13" Small Box

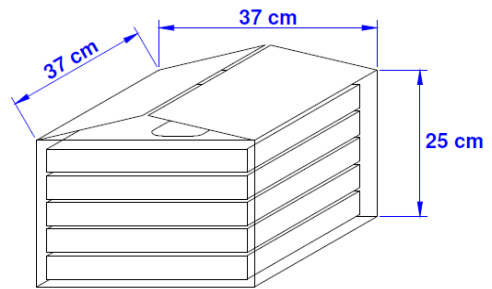

Large Box

SIZE/mm	Reels in Small Box	Small Box in Large Box
201610	4	3
4015	4	3
4018	4	3
4020	4	3
5012	4	3
5015	4	3
5018	4	3
5020	4	3
5030	4	3
6012	3	3
6015	3	3
6018	3	3
6020	3	3
6024	3	3
6030	3	3
6040	3	3

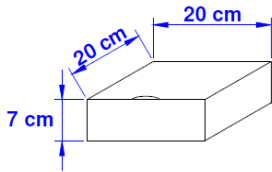

7" Small Box

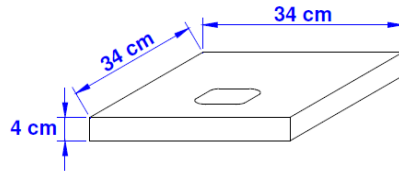

13" Small Box

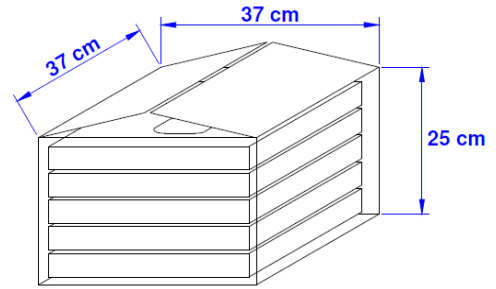

Large Box

SIZE/mm	Reels in Small Box	Small Box in Large Box
6050	3	3
8030	2	3
8040	2	3
8050	2	3
8060	2	3
10020	3	3
10030	3	3
10040	3	3
10050	3	3
10060	3	3
10070	3	3
12035	3	3
12040	3	3
12050	3	3
12060	3	3
12065	3	3



IMPORTANT NOTICE

AiT Semiconductor Inc. (AiT) reserves the right to make changes to any its product, specifications, to discontinue any integrated circuit product or service without notice, and advises its customers to obtain the latest version of relevant information to verify, before placing orders, that the information being relied on is current.

AiT Semiconductor Inc.'s integrated circuit products are not designed, intended, authorized, or warranted to be suitable for use in life support applications, devices or systems or other critical applications. Use of AiT products in such applications is understood to be fully at the risk of the customer. As used herein may involve potential risks of death, personal injury, or severe property, or environmental damage. In order to minimize risks associated with the customer's applications, the customer should provide adequate design and operating safeguards.

AiT Semiconductor Inc. assumes to no liability to customer product design or application support. AiT warrants the performance of its products of the specifications applicable at the time of sale.