



DESCRIPTION

The AL1G04 is a single inverter gate performs the Boolean function $Y=\bar{A}$.

The AL1G04 is designed for 1.65V to 5.5V V_{cc} operation.

AL1G04 operates over an ambient temperature range of -40°C to +125°C.

The AL1G04 is available in SOT25, SC70-5 and DFN6(1x1) packages. I

ORDERING INFORMATION

Package Type	Part Number	
SOT-25 SPQ: 3,000pcs/Reel	E5	AL1G04E5R
		AL1G04E5VR
SC70-5 SPQ:3,000pcs/Reel	C5	AL1G04C5R
		AL1G04C5VR
DFN6(1x1) SPQ:5,000pcs/Reel	J6C	AL1G04J6CR
		AL1G04J6CVR
Note	V: Halogen free Package R: Tape & Reel	
AiT provides all RoHS products		

FEATURES

- Operating Voltage Range: 1.65V to 5.5V
- Low Power Consumption: 1µA (Max).
- Operating Temperature Range: -40°C to +125°C
- Input Accept Voltage to 5.5V
- High Output Drive: ±24mA at $V_{cc}=3.0V$
- I_{off} Supports Partial-Power-Down Mode Operation.

APPLICATION

- ATCA Solutions
- Active Noise Cancellation (ANC)
- Barcode Scanner
- Blood Pressure Monitor
- CPAP Machine
- Cable Solutions
- DLP 3D Machine Vision, Hyperspectral Imaging, Optical Networking, and Spectroscopy
- E-Book
- Embedded PC
- Field Transmitter: Temperature or Pressure Sensor
- Fingerprint Biometrics
- HVAC: Heating, Ventilating, and air Conditioning
- Network-Attached Storage (NAS)
- Server Motherboard and PSU
- Software Defined Radio (SDR)
- TV: High-Definition (HDTV), LCD, and Digital
- Video Communications System
- Wireless Data Access Card, Headset, Keyboard, Mouse, and LAN Card
- X-ray: Baggage, Scanner, Medical, and Dental
- Isolate RS-485 Communication
- Factory Automation
- Photovoltaic Inverter
- Motor Driver

SIMPLIFIED SCHEMATIC

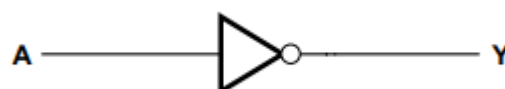



PIN DESCRIPTION

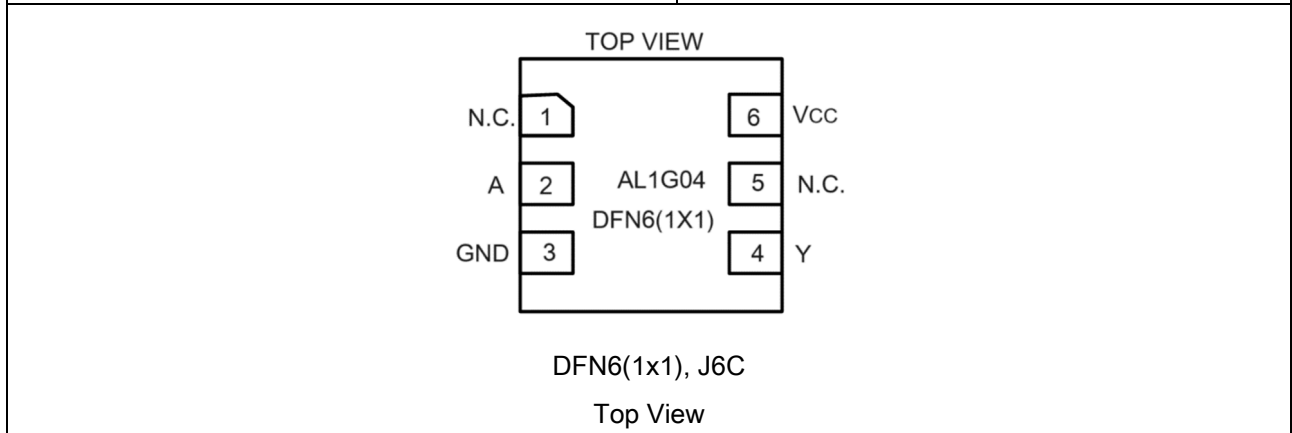
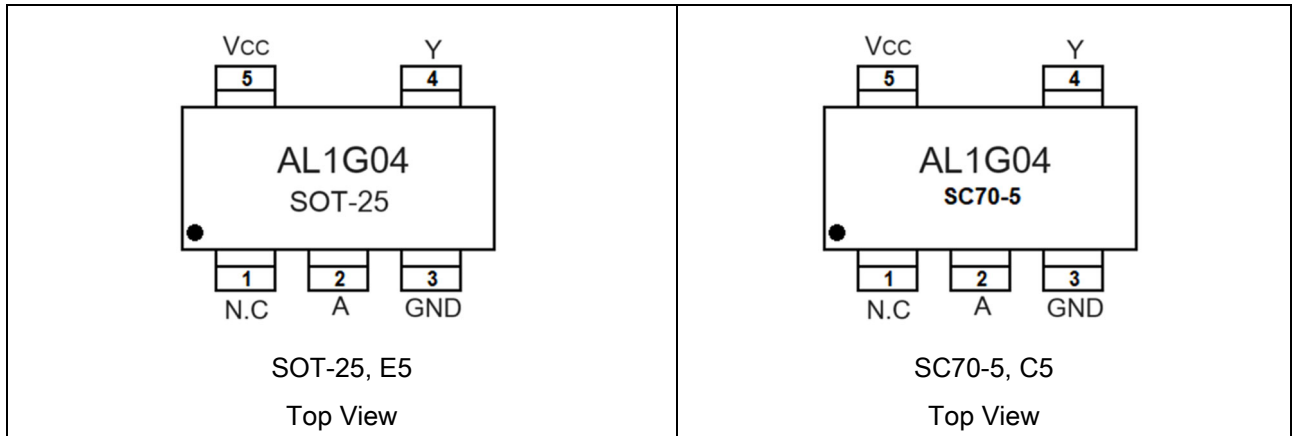

PIN#			Symbol	Function
SOT-25	SC70-5	DFN6(1x1)		
1	1	1	N.C.	Not Connected
2	2	2	A	Input
3	3	3	GND	Ground
4	4	4	Y	Output
-	-	5	N.C.	Not Connected
5	5	6	V _{CC}	Power Pin



ABSOLUTE MAXIMUM RATINGS

over operating free-air temperature range (unless otherwise noted) ⁽¹⁾

V _{CC} , Supply Voltage Range		-0.5V ~ + 6.5V
V _I , Input Voltage Range ⁽¹⁾		-0.5V ~ + 6.5V
V _O , Voltage Range Applied to Any Output in The High-Impedance or Power-Off State ⁽¹⁾		-0.5V ~ + 6.5V
V _O , Voltage Range Applied to any Output in the High or Low State ^{(1) (2)}		-0.5V ~ V _{CC} +0.5V
I _{IK} , Input Clamp Current	V _I < 0	-50mA
I _{OK} , Output Clamp Current	V _O < 0	-50mA
I _O , Continuous Output Current		±50mA
I _O , Continuous Current through V _{CC} or GND		±100mA
θ _{JA} , Package Thermal Impedance ⁽³⁾	SOT-25	230°C/W
	SC70-5	380°C/W
	DFN6(1x1)	438°C/W
T _J , Junction Temperature ⁽⁴⁾		-65°C ~ +150°C
T _{STG} , Storage Temperature		-65°C ~ +150°C

Stresses above may cause permanent damage to the device. These are stress ratings only and functional operation of the device at these or any other conditions beyond those indicated in the Electrical Characteristics are not implied. Exposure to absolute maximum rating conditions for extended periods may affect device reliability.

- (1) The input and output negative-voltage ratings may be exceeded if the input and output current ratings are observed.
- (2) The value of V_{CC} is provided in the Recommended Operating Conditions table.
- (3) The package thermal impedance is calculated in accordance with JESD-51.
- (4) The maximum power dissipation is a function of T_{J(MAX)}, R_{θJA}, and T_A. The maximum allowable power dissipation at any ambient temperature is P_D = (T_{J(MAX)} - T_A) / R_{θJA}. All numbers apply for packages soldered directly onto a PCB.

ESD RATINGS

Parameter	Symbol	Min	Unit
Human-Body Model (HBM), per ANSI/ESDA/JEDEC JS-001 ⁽¹⁾	V _(ESD) Electrostatic discharge	±4000	V
Charged-Device Model (CDM), per ANSI/ESDA/JEDEC JS-002 ⁽²⁾		±1500	
Machine Model (MM)		±200	

- (1) JEDEC document JEP155 states that 500 V HBM allows safe manufacturing with a standard ESD control process.
- (2) JEDEC document JEP157 states that 250 V CDM allows safe manufacturing with a standard ESD control process.



RECOMMENDED OPERATING CONFITIONS

TA=25°C, unless otherwise noted. (1)

Parameter	Symbol	Conditions	Min	Typ.	Max	Unit
Supply Voltage	V _{CC}	Operating	1.65	-	5.5	V
		Data Retention only	1.50	-	-	
High-Level Input Voltage	V _{IH}	V _{CC} = 1.65 V ~1.95 V	0.65x V _{CC}	-		V
		V _{CC} = 2.3V ~2.7 V	1.70	-		
		V _{CC} = 3 V ~3.6 V	2	-		
		V _{CC} = 4.5 V ~5.5 V	0.70x V _{CC}	-		
Low-Level Input Voltage	V _{IL}	V _{CC} = 1.65 V ~1.95 V	-	-	0.35x V _{CC}	V
		V _{CC} = 2.3V ~2.7 V	-	-	0.70	
		V _{CC} = 3 V ~3.6 V	-	-	0.80	
		V _{CC} = 4.5 V ~5.5 V	-	-	0.30x V _{CC}	
Input Voltage	V _I		0	-	5.5	V
Output Voltage	V _O		0	-	5.5	V
Input Transition Rise or Fall	Δt/Δv	V _{CC} = 1.8V±0.15V, 2.5V±0.2V	-	-	20	ns/V
		V _{CC} = 3.30 V ± 0.3 V	-	-	10	
		V _{CC} = 5 V ± 0.5V	-	-	5	
Operating Temperature	T _A		-40	-	+125	°C

(1) All currents into the device are positive and all currents out of the device are negative; all voltages are to ground unless otherwise specified.



DC CHARACTERISTICS

Parameter		Conditions	Min	Typ.	Max	Unit
V _{OH}		I _{OH} = -100 μA, V _{CC} =1.65~5.5V	V _{CC} -0.1	-	-	V
		I _{OH} = -4mA, V _{CC} =1.65V	1.20	-	-	
		I _{OH} = -8mA, V _{CC} =2.3V	1.90	-	-	
		I _{OH} = -16mA, V _{CC} =3V	2.40	-	-	
		I _{OH} = -24mA, V _{CC} =3V	2.30	-	-	
		I _{OH} = -32mA, V _{CC} =4.5V	3.80	-	-	
V _{OL}		I _{OH} = 100 μA, V _{CC} =1.65~5.5V	-	-	0.10	V
		I _{OH} = 4mA, V _{CC} =1.65V	-	-	0.45	
		I _{OH} = 8mA, V _{CC} =2.3V	-	-	0.30	
		I _{OH} = 16mA, V _{CC} =3V	-	-	0.40	
		I _{OH} = 24mA, V _{CC} =3V	-	-	0.55	
		I _{OH} = 32mA, V _{CC} =4.5V	-	-	0.55	
I _i	A Input	V _i = 5.5V or GND, V _{CC} =0V~5.5V		±0.10	±1	μA
I _{off}		V _i or V _o = 5.5V, V _{CC} =0V	+25°C	±0.10	±1	μA
			-40°C ~ +125°C	-	-	
I _{CC}		V _i = 5.5V or GND, I _o =0, V _{CC} =1.65V~5.5V	+25°C	0.10	1	μA
			-40°C ~ +125°C	-	-	
ΔI _{CC}		One input at V _{CC} -0.6V, Other inputs at V _{CC} or GND, V _{CC} =3V~5.5V	-	-	500	μA
C _i , Input Capacitance		V _i = V _{CC} or GND, V _{CC} =3.3V	-	4		pF

AC CHARACTERISTICS

Parameter	Symbol	Conditions	Min	Typ.	Max	Unit	
Propagation Delay	t _{pd}	V _{CC} =1.8V±0.15V, C _L =30pF, R _L =1KΩ	-	13	-	ns	
		V _{CC} =2.5V±0.2V, C _L =30pF, R _L =500Ω	-	5.1	-		
		V _{CC} =3.3V±0.3V, C _L =50pF, R _L =500Ω	-	4.2	-		
		V _{CC} =5V±0.5V, C _L =50pF, R _L =500Ω	-	3.3	-		
Power Dissipation Capacitance	C _{pd}	f=10MHz	V _{CC} =1.8V±0.15V	-	16	-	pF
			V _{CC} =2.5V±0.2V	-	18	-	
			V _{CC} =3.3V±0.3V	-	18	-	
			V _{CC} =5V±0.5V	-	20	-	



PARAMETER MEASUREMENT INFORMATION

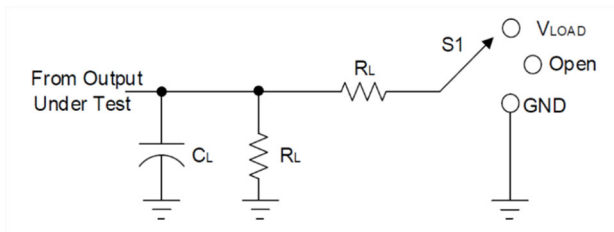

TEST	S1
t_{PLH}/t_{PHL}	Open
t_{PZL}/t_{PZL}	V_{LOAD}
t_{PHZ}/t_{PZH}	GND

V_{CC}	Inputs		V_M	V_{LOAD}	C_L	R_L	V_{Δ}
	V_I	tr/tf					
$1.8V \pm 0.15V$	V_{CC}	$\leq 2ns$	$V_{CC}/2$	$2 \times V_{CC}$	30pF	1k Ω	0.15V
$2.5V \pm 0.2V$	V_{CC}	$\leq 2ns$	$V_{CC}/2$	$2 \times V_{CC}$	30pF	500 Ω	0.15V
$3.3V \pm 0.3V$	3V	$\leq 2.5ns$	1.5V	6V	50pF	500 Ω	0.3V
$5V \pm 0.5V$	V_{CC}	$\leq 2.5ns$	$V_{CC}/2$	$2 \times V_{CC}$	30pF	500 Ω	0.15V

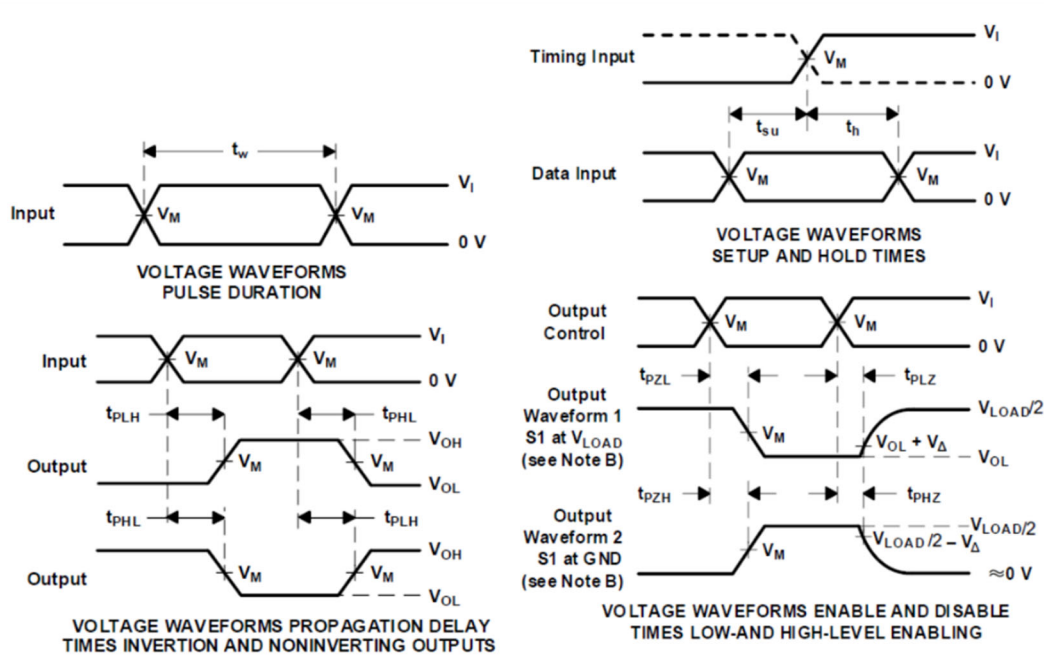

Fig 1. Load Circuit and Voltage Waveforms

- (A) C_L includes probe and jig capacitance.
- (B) Waveform 1 is for an output with internal conditions such that the output is low, except when disabled by the output control. Waveform 2 is for an output with internal conditions such that the output is high, except when disabled by the output control.
- (C) All input pulses are supplied by generators having the following characteristics: $PRR \leq 10 \text{ MHz}$, $Z_o = 50 \Omega$.
- (D) The outputs are measured one at a time, with one transition per measurement.
- (E) Since this device has open-drain outputs, t_{PLZ} and t_{PZL} are the same as t_{pd} .
- (F) t_{PZL} is measured at V_M .
- (G) t_{PLZ} is measured at $V_{OL} + V_{\Delta}$.
- (H) All parameters and waveforms are not applicable to all devices.



PACKAGE INFORMATION

Dimension in SOT-25 (Unit: mm)

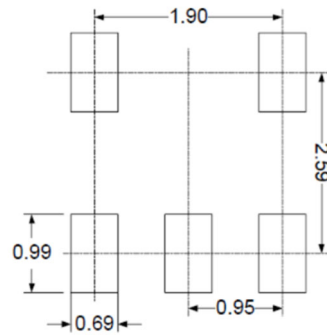
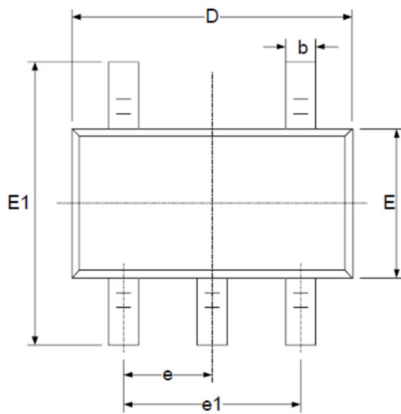

RECOMMENDED LAND PATTERN

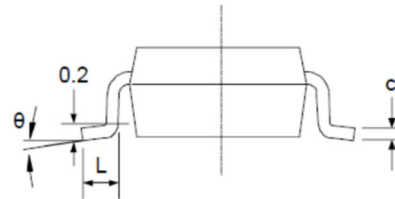
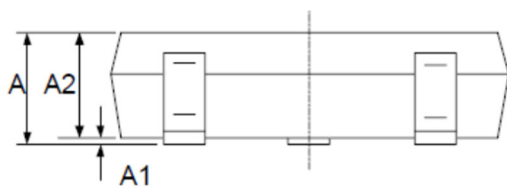

Symbol	Millimeters	
	Min	Max
A	1.050	1.250
A1	0.000	0.100
A2	1.050	1.150
b	0.300	0.500
c	0.100	0.200
D	2.820	3.020
E	1.500	1.700
E1	2.650	2.950
e	0.950 BSC.	
e1	1.800	2.000
L	0.300	0.600
θ	0°	8°



Dimension in SC70-5 (Unit: mm)

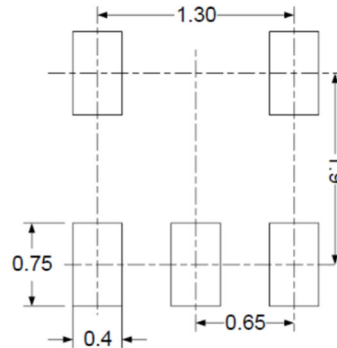
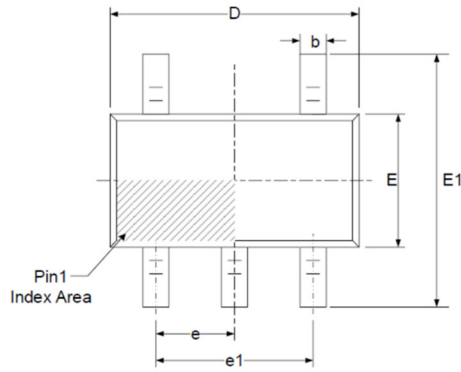

RECOMMENDED LAND PATTERN

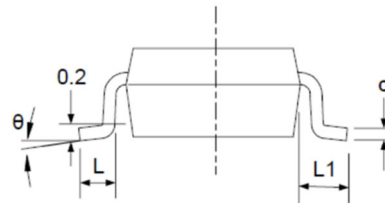
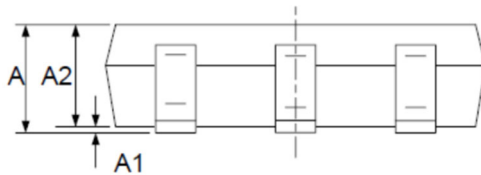

Symbol	Millimeters	
	Min	Max
A	0.900	1.100
A1	0.000	0.100
A2	0.900	1.000
b	0.150	0.350
c	0.080	0.150
D	2.000	2.200
E	1.150	1.350
E1	2.150	2.450
e	0.650 BSC.	
e1	1.300 BSC.	
L	0.260	0.460
L1	0.525	
θ	0°	8°



Dimension in DFN6(1x1) (Unit: mm)

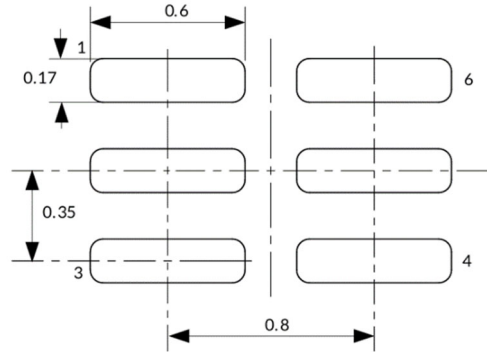
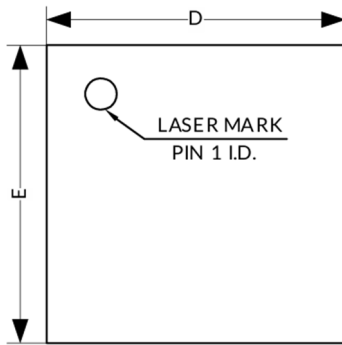

RECOMMENDED LAND PATTERN

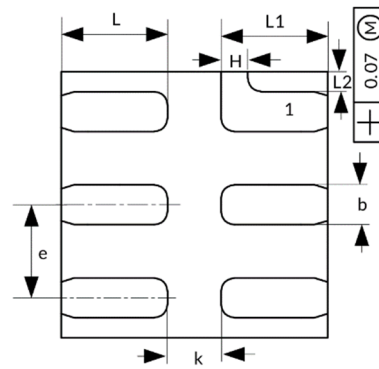
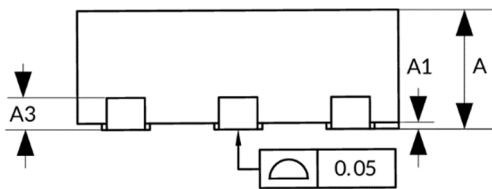

Symbol	Millimeters	
	Min	Max
A	0.340	0.400
A1	0.000	0.050
A3	0.100 REF.	
b	0.100	0.200
D	0.950	1.050
E	0.950	1.050
e	0.300	0.400
H	0.100 BSC.	
K	0.150	-
L	0.350	0.450
L1	0.350	0.450
L2	0.075 REF.	



IMPORTANT NOTICE

AiT Semiconductor Inc. (AiT) reserves the right to make changes to any its product, specifications, to discontinue any integrated circuit product or service without notice, and advises its customers to obtain the latest version of relevant information to verify, before placing orders, that the information being relied on is current.

AiT Semiconductor Inc.'s integrated circuit products are not designed, intended, authorized, or warranted to be suitable for use in life support applications, devices or systems or other critical applications. Use of AiT products in such applications is understood to be fully at the risk of the customer. As used herein may involve potential risks of death, personal injury, or severe property, or environmental damage. In order to minimize risks associated with the customer's applications, the customer should provide adequate design and operating safeguards.

AiT Semiconductor Inc. assumes to no liability to customer product design or application support. AiT warrants the performance of its products of the specifications applicable at the time of sale.