

**DESCRIPTION**

The AM065NS10H is available in the TO-220 Package.

BVDSS	RDSON	ID
100V	6.5mΩ	85A

**APPLICATIONS**

- Synchronous Rectification for AC/DC Quick Charger
- Battery Management
- UPS (Uninterruptible Power Supplies)

**FEATURES**

- Extremely Low On-Resistance  $R_{DS(on)}$
- Excellent  $Q_g \times R_{DS(on)}$  Product (FOM)
- Qualified According to JEDEC Criteria
- Excellent Low Ciss
- High Robustness and Reliability
- Increases Maximum Current Capability
- Low Power Loss, High Power Density
- Easy Paralleling

**PIN DESCRIPTION**

Pin#	Symbol	Function
1	G	Gate
2	D	Drain
3	S	Source

**ORDERING INFORMATION**

Package Type	Part Number	
TO-220 SPQ: 50pcs /Tube	T3	AM065NS10HT3VU
Note	V: Halogen free Package U: Tube Package	
AiT provides all RoHS products		

**ABSOLUTE MAXIMUM RATINGS**

$T_C=25^\circ\text{C}$ , unless otherwise Noted

$V_{DS}$ , Drain-Source Voltage		100V
$V_{GS}$ , Gate-Source Voltage		$\pm 20\text{V}$
$I_D$ , Continue Drain Current	$T_C=25^\circ\text{C}$ (Silicon limit)	85A
	$T_C=25^\circ\text{C}$ (Package Limited)	100A
	$T_C=100^\circ\text{C}$ (Silicon limit)	54A
	$T_a=25^\circ\text{C}$	10A
$I_{D\_pulse}$ , Pulsed Drain Current	$T_C = 25^\circ\text{C}$ , $t_p = 100\mu\text{s}$	340A
$E_{AS}$ , Avalanche Energy, Single Pulse	$L=0.5\text{mH}$ , $V_{ds}=50\text{V}$	64mJ
$R_{thJC}$ , Thermal Resistance, Junction-Case		1.20°C/W
$R_{thJA}$ , Thermal Resistance, Junction-Ambient (Min. Footprint)		80°C/W
Ptot, Power Dissipation	$T_C=25^\circ\text{C}$	105W
	$T_a=25^\circ\text{C}$	1.6W
$T_J$ , Operating Junction Temperature		$-55^\circ\text{C}\sim+150^\circ\text{C}$
$T_{STG}$ , Storage Temperature		$-55^\circ\text{C}\sim+150^\circ\text{C}$
$T_{sold}$ , Soldering Temperature, Wave Soldering Only Allowed at Leads (1.6mm from case for 10s)		260°C

Stresses above may cause permanent damage to the device. These are stress ratings only and functional operation of the device at these or any other conditions beyond those indicated in the Electrical Characteristics are not implied. Exposure to absolute maximum rating conditions for extended periods may affect device reliability.



**ELECTRICAL CHARACTERISTICS**

T<sub>j</sub> = 25°C, unless otherwise Noted

Parameter	Symbol	Conditions	Min	Typ.	Max	Unit
<b>Static Characteristic</b>						
Drain-Source Breakdown Voltage	B <sub>VDS</sub>	V <sub>GS</sub> =0V, I <sub>D</sub> =250μA	100	-	-	V
Zero Gate Voltage Drain Current	I <sub>DSS</sub>	V <sub>DS</sub> = 100V, T <sub>J</sub> = 25°C	-	0.02	1	μA
		V <sub>GS</sub> =0V, T <sub>J</sub> = 150°C	-	-	100	
Gate-Source Leakage Current	I <sub>GSS</sub>	V <sub>DS</sub> = 0V, V <sub>GS</sub> =±20V	-	±10	±100	nA
Drain-Source On-State Resistance	R <sub>DS(ON)</sub>	V <sub>GS</sub> =10V, I <sub>D</sub> =40A	-	6.5	8	mΩ
Gate Threshold Voltage	V <sub>GS(th)</sub>	V <sub>DS</sub> =V <sub>GS</sub> , I <sub>D</sub> =250μA	2	-	4	V
Transconductance	g <sub>fs</sub>	V <sub>DS</sub> =5V, I <sub>D</sub> =40A	-	45	-	S
<b>Dynamic Characteristic</b>						
Input Capacitance	C <sub>iss</sub>	V <sub>DS</sub> =50V, V <sub>GS</sub> =0V, f=1MHz	-	2042	-	pF
Output Capacitance	C <sub>oss</sub>		-	1002	-	
Reverse Transfer Capacitance	C <sub>rss</sub>		-	75	-	
Total Gate Charge	Q <sub>G</sub>	V <sub>DS</sub> = 50V, I <sub>D</sub> =40A, V <sub>GS</sub> = 10V	-	37	-	nC
Gate-Source charge	Q <sub>gS</sub>		-	13	-	
Gate-Drain charge	Q <sub>gd</sub>		-	3	-	
Turn-On Delay Time	t <sub>d(on)</sub>	V <sub>DD</sub> = 50V, R <sub>G_ext</sub> =10Ω V <sub>GS</sub> = 10V, I <sub>D</sub> =13A	-	22	-	ns
Rise Time	t <sub>r</sub>		-	2	-	
Turn-Off Delay Time	t <sub>d(off)</sub>		-	44	-	
Fall Time	t <sub>f</sub>		-	5	-	
Gate Resistance	R <sub>g</sub>	V <sub>GS</sub> =0V, V <sub>DS</sub> =0V, f=1MHz	-	1.5	-	Ω
<b>Body Diode Characteristic</b>						
Body Diode Continuous Forward Current	I <sub>S</sub>	T <sub>C</sub> = 25°C	-	-	85	A
Body Diode Pulsed Current	I <sub>S_pulse</sub>	T <sub>C</sub> = 25°C	-	-	340	A
Body Diode Forward Voltage	V <sub>SD</sub>	V <sub>GS</sub> =0V, I <sub>SD</sub> =40A	-	0.9	1.2	V
Body Diode Reverse Recovery Time	t <sub>rr</sub>	I <sub>F</sub> =1A, di/dt=100A/μs	-	62	-	ns
Body Diode Reverse Recovery Charge	Q <sub>rr</sub>		-	-	129	-



## TYPICAL PERFORMANCE CHARACTERISTICS

Fig 1. Output Characteristics

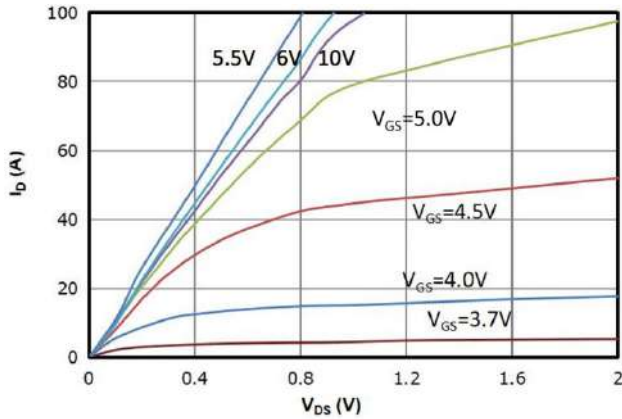

Fig 2. Transfer Characteristics

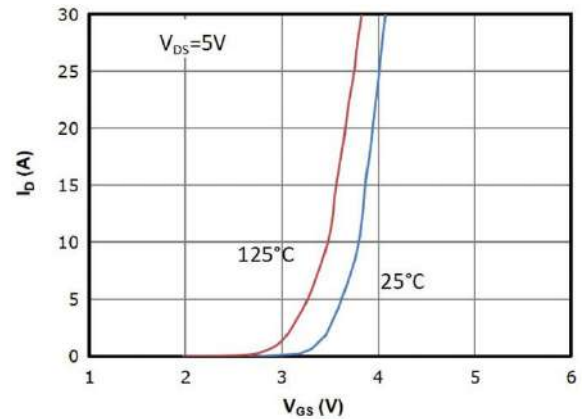

Fig 3.  $R_{DS(on)}$  vs. Drain Current and Gate Voltage

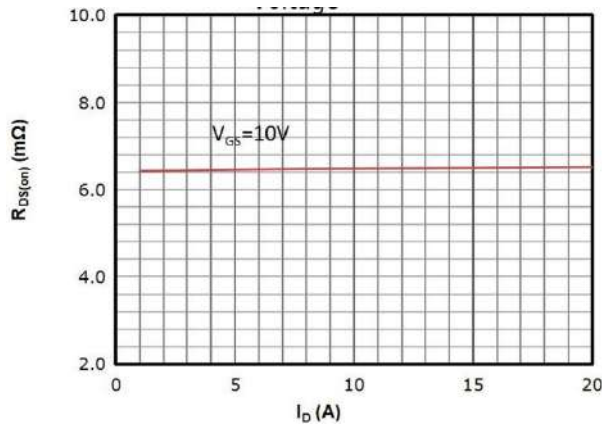

Fig 4.  $R_{DS(on)}$  vs. Gate Voltage

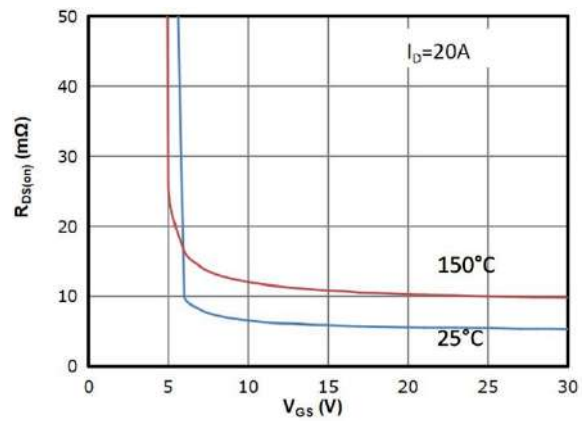

Fig 5.  $R_{DS(on)}$  vs. Temperature

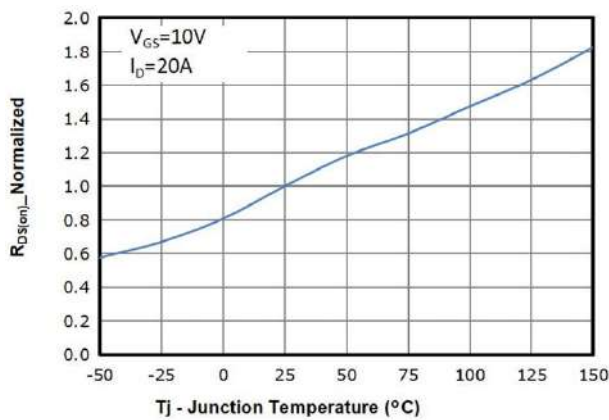

Fig 6.  $V_{GS(th)}$  vs. Temperature

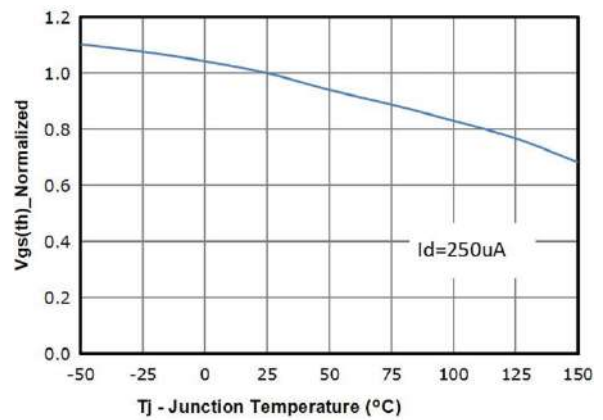



Fig 7. BVdss vs. Temperature

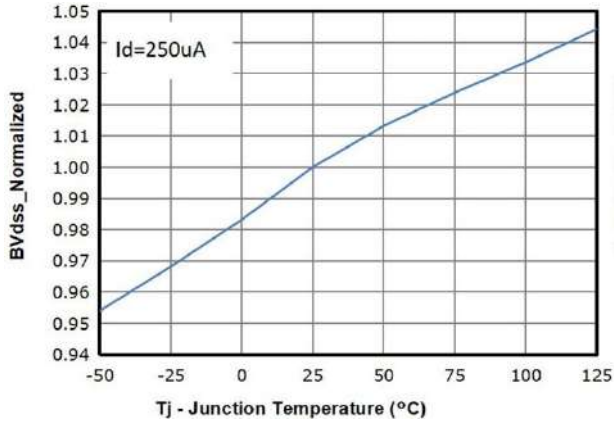

Fig 8. Capacitance Characteristics

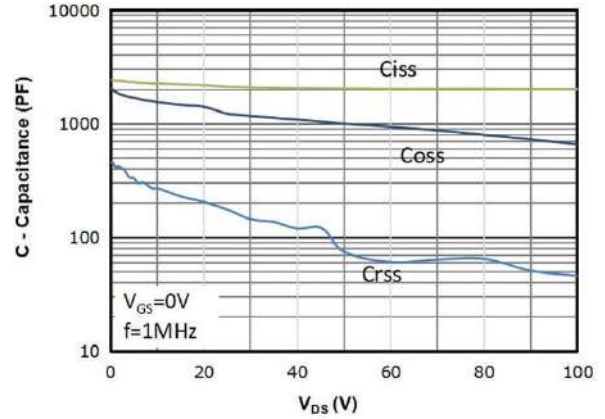

Fig 9. Gate Charge Characteristic

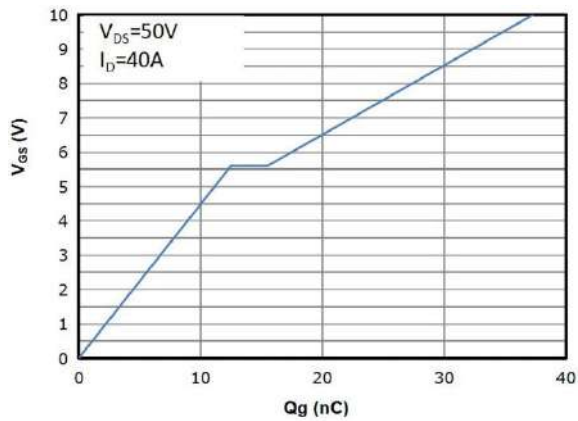

Fig 10. Body-Diode Forward Characteristic

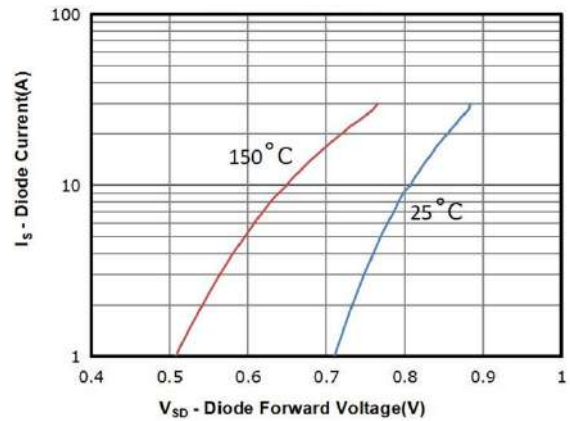

Fig 11. Power Dissipation

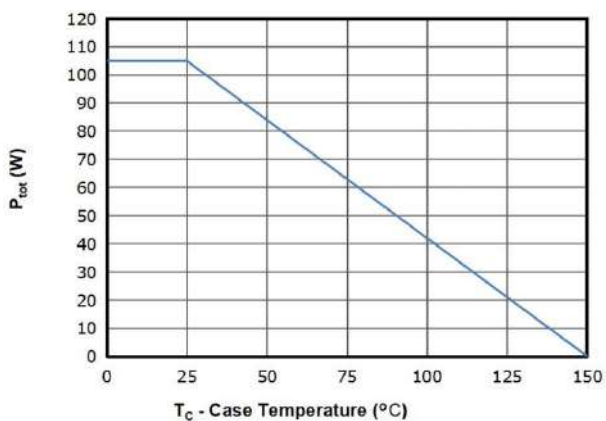

Fig 12. Drain Current Derating

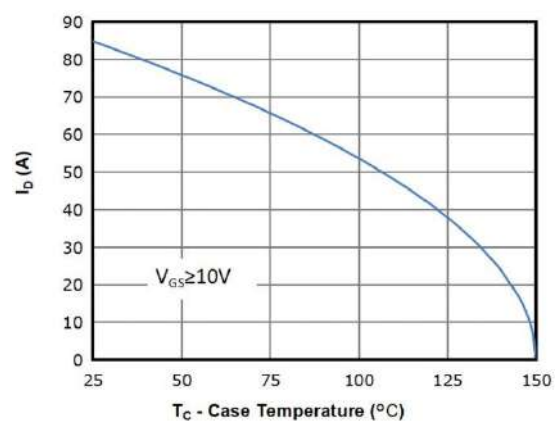



Fig 13. Safe Operating Area

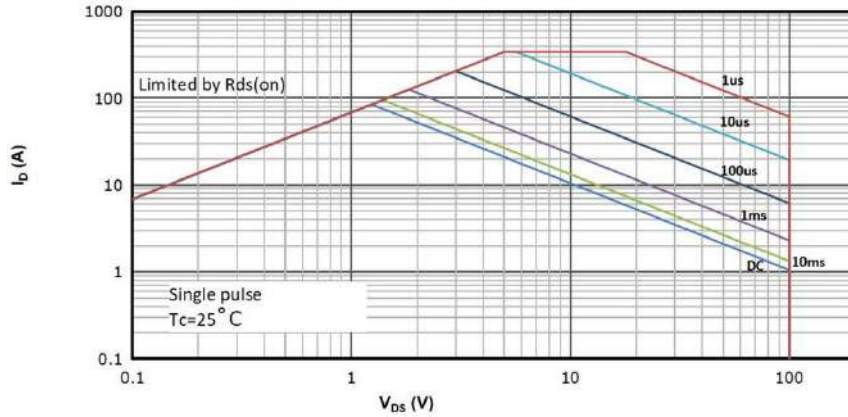

Fig 14. Max. Transient Thermal Impedance

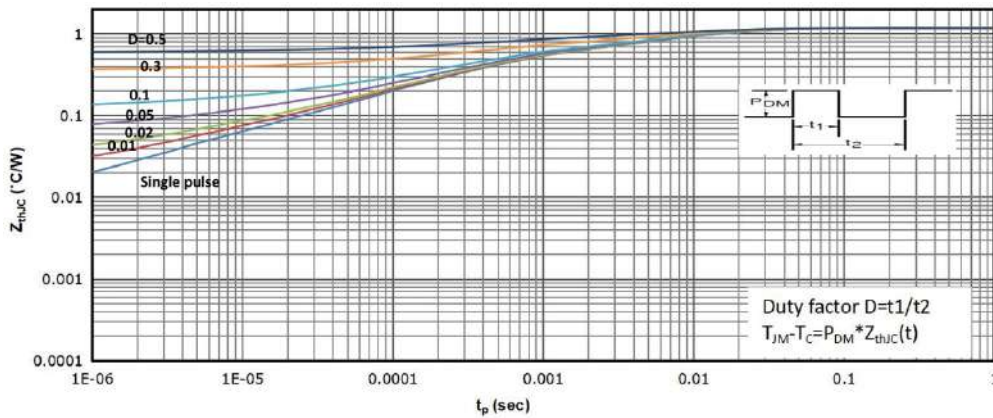

Fig 15. Gate Charge Test Circuit & Waveform

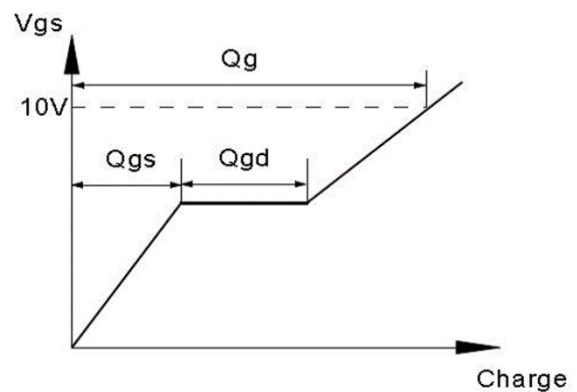
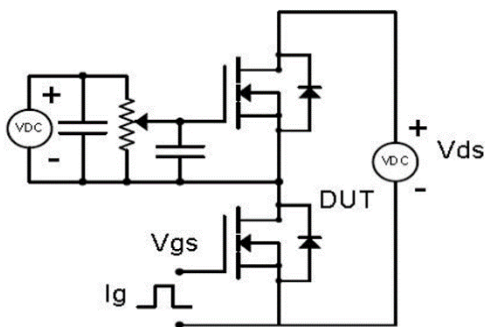



Fig 16. Resistive Switching Test Circuit & Waveforms

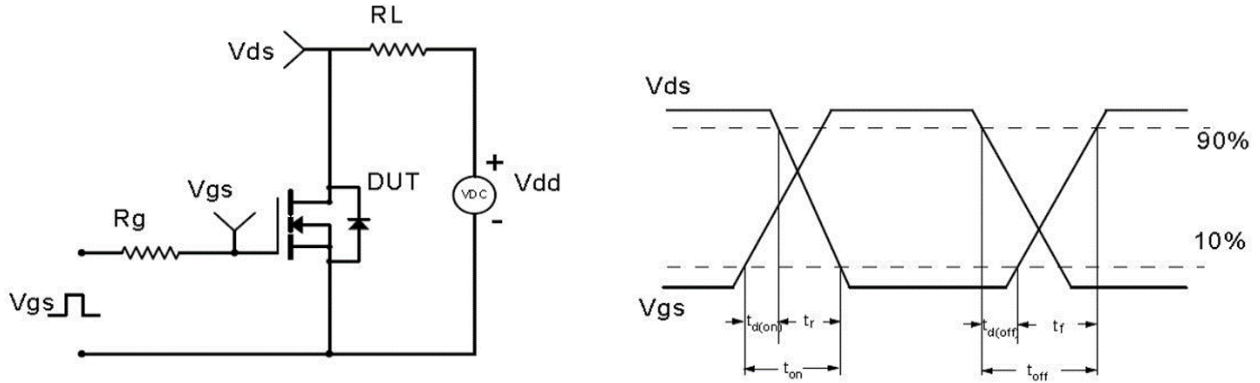

Fig 17. Unclamped Inductive Switching (UIS) Test Circuit & Waveforms

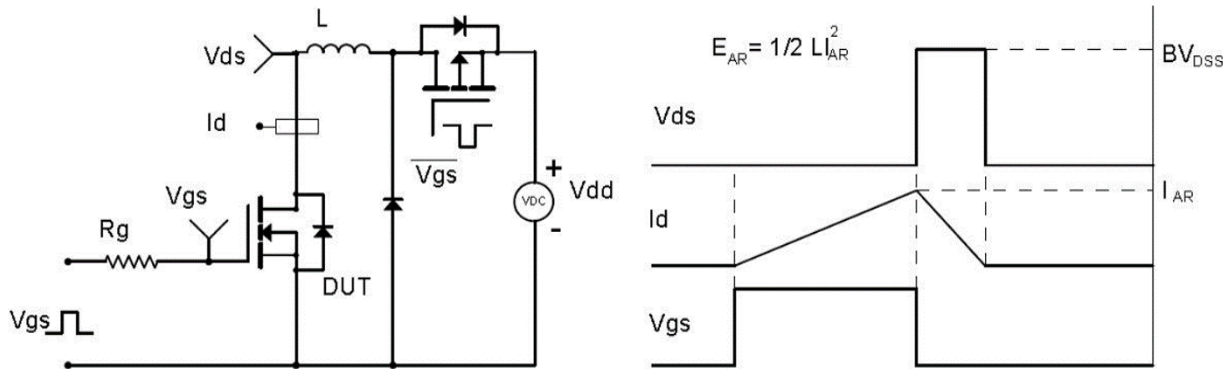
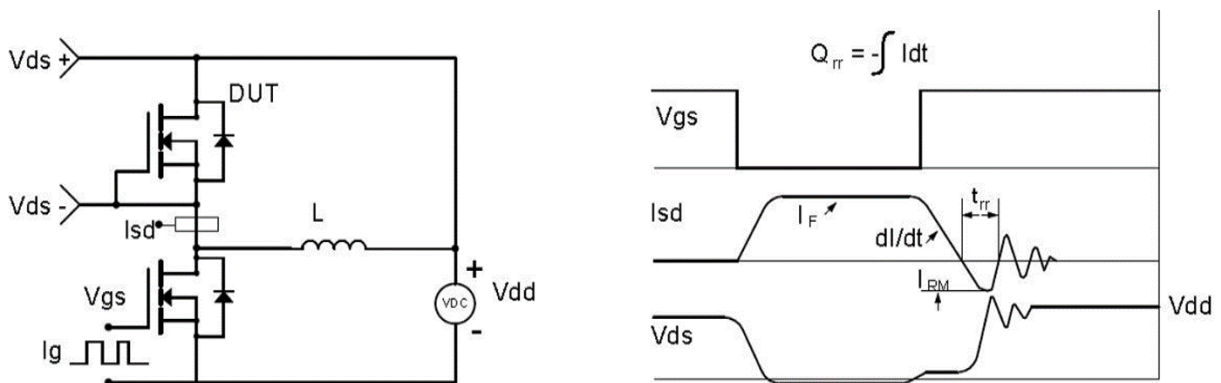

Fig 18. Diode Recovery Test Circuit & Waveforms





**PACKAGE INFORMATION**

Dimension in TO-220(Unit: mm)

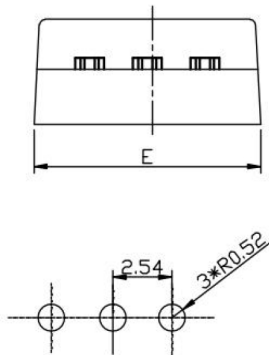
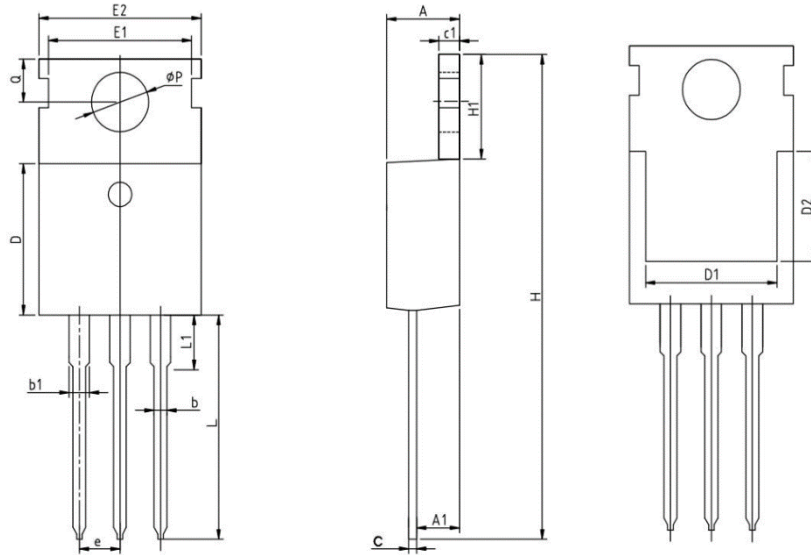

RECOMMENDED LAND PATTERN

Symbol	Millimeter	
	Min.	Max.
A	4.400	4.800
A1	2.250	2.550
b	0.720	0.920
b1	1.120	1.420
c	0.400	0.600
c1	1.200	1.400
D	8.800	9.400
D1	7.750	8.150
D2	6.550	6.950
e	2.540	
E	9.650	10.350
E1	8.700	
E2	9.700	10.300
H	28.700	29.700
H1	6.250	6.850
L	13.200	13.800
L1	2.800	3.400
Q	2.600	3.000
φP	3.450	3.750



## IMPORTANT NOTICE

AiT Semiconductor Inc. (AiT) reserves the right to make changes to any its product, specifications, to discontinue any integrated circuit product or service without notice, and advises its customers to obtain the latest version of relevant information to verify, before placing orders, that the information being relied on is current.

AiT Semiconductor Inc. integrated circuit products are not designed, intended, authorized, or warranted to be suitable for use in life support applications, devices or systems or other critical applications. Use of AiT products in such applications is understood to be fully at the risk of the customer. As used herein may involve potential risks of death, personal injury, or server property, or environmental damage. In order to minimize risks associated with the customer's applications, the customer should provide adequate design and operating safeguards.

AiT Semiconductor Inc. assumes to no liability to customer product design or application support. AiT warrants the performance of its products of the specifications applicable at the time of sale.