



**DESCRIPTION**

The AM10T65 is available in TO-252 Packages.

V <sub>CES</sub>	650V
IC	15A
V <sub>CE (sat).typ</sub>	1.4V
P <sub>D</sub> (T <sub>C</sub> =25°C)	35W

**APPLICATION**

- UPS
- Air Condition
- Motor Drives
- PFC

**ORDERING INFORMATION**

Package Type	Part Number	
TO-252 SPQ:2,500pcs /Reel	D	AM10T65DVR
Note	V: Halogen free Package R: Tape & Reel	
AiT provides all RoHS products		

**FEATURE**

- Fast Switching
- Low V<sub>CE (sat)</sub>
- Positive temperature coefficient
- Very soft, fast recovery anti-parallel diode

**PIN DESCRIPTION**

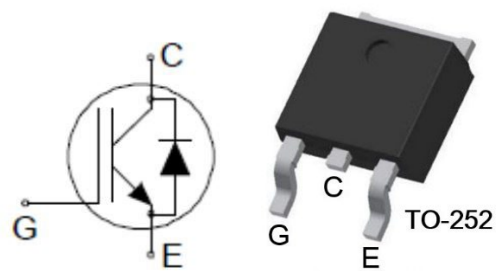

Pin#	Symbol	Function
1	G	Gate
2	C	Collector
3	E	Emitter

**ABSOLUTE MAXIMUM RATINGS**T<sub>A</sub> = 25°C, unless otherwise specified.

Parameter	Symbol	Value	Unit
Collector-Emitter Voltage	V <sub>CES</sub>	650	V
Collector Current @ T <sub>C</sub> = 25 °C	I <sub>C</sub>	30	A
Collector Current @ T <sub>C</sub> = 100 °C		10	A
Pulsed Collector Current * @ T <sub>C</sub> = 25 °C	I <sub>CM</sub>	40	A
Diode Continuous Forward Current @ T <sub>C</sub> = 25 °C	I <sub>F</sub>	20	A
Diode Continuous Forward Current @ T <sub>C</sub> = 100 °C		10	A
Diode Maximum Forward Current @ T <sub>C</sub> = 25 °C	I <sub>FM</sub>	30	A
Gate-Emitter Voltage	V <sub>GES</sub>	±30	V
Power Dissipation @ T <sub>C</sub> = 25 °C	P <sub>D</sub>	83	W
Operating Junction Temperature Range	T <sub>J</sub>	150	°C
Storage Temperature Range	T <sub>stg</sub>	-55 to 150	°C
Maximum Temperature for Soldering	T <sub>L</sub>	260	°C
<b>THERMAL RESISTANCE</b>			
Junction-to-Case (IGBT)	R <sub>θJC</sub>	1.5	°C/W
Junction-to-Case (Diode)	R <sub>θJC</sub>	2.5	°C/W
Junction-to-Ambient	R <sub>θJA</sub>	62	°C/W

Stresses above may cause permanent damage to the device. These are stress ratings only and functional operation of the device at these or any other conditions beyond those indicated in the Electrical Characteristics are not implied. Exposure to absolute maximum rating conditions for extended periods may affect device reliability.

\*Pulse width limited by maximum junction temperature



**ELECTRICAL CHARACTERISTICS**

T<sub>A</sub> = 25°C, unless otherwise specified.

Parameter	Symbol	Conditions	Min	Typ.	Max.	Unit
<b>OFF CHARACTERISTICS</b>						
Collector-Emitter Breakdown Voltage	V <sub>CES</sub>	V <sub>GE</sub> = 0V, I <sub>C</sub> = 250μA	650	-	-	V
Collector-Emitter Leakage Current	I <sub>CES</sub>	V <sub>CE</sub> = 650V, V <sub>GE</sub> = 0V	-	-	4	μA
Gate-Emitter Leakage Current	I <sub>GES(F)</sub>	V <sub>GE</sub> = +30V	-	-	200	nA
Gate-Emitter Reverse Leakage	I <sub>GES(R)</sub>	V <sub>GE</sub> = -30V	-	-	-200	nA
<b>ON CHARACTERISTICS</b>						
Collector-Emitter Saturation Voltage	V <sub>CE(sat)</sub>	V <sub>GE</sub> = 15V, I <sub>C</sub> = 10A	-	1.4	1.75	V
Gate Threshold Voltage	V <sub>GE(TH)</sub>	V <sub>CE</sub> = V <sub>GE</sub> , I <sub>C</sub> = 1mA	4.5	5.2	5.9	V
Pulse width tp ≤ 300μs, δ ≤ 2%						
<b>Dynamic CHARACTERISTICS</b>						
Input Capacitance	C <sub>iss</sub>	V <sub>GE</sub> = 0V	-	947	-	pF
Output Capacitance	C <sub>oss</sub>	V <sub>CE</sub> = 25V	-	32	-	
Reverse Transfer Capacitance	C <sub>rss</sub>	f = 1.0MHz	-	9	-	
Total Gate Charge	Q <sub>g</sub>	I <sub>C</sub> = 10A V <sub>CE</sub> = 520V V <sub>GE</sub> = 15V	-	39	-	nC
<b>Switching CHARACTERISTICS</b>						
Turn-on Delay Time	td(on)	I <sub>C</sub> = 10A V <sub>CE</sub> = 400V V <sub>GE</sub> = 15V R <sub>G</sub> = 10Ω T = 25°C Inductive Load	-	20	-	ns
Rise Time	tr		-	8	-	
Turn-Off Delay Time	td(off)		-	73	-	
Fall Time	tf		-	65	-	
Turn-On Switching Loss	E <sub>on</sub>		-	0.15	-	mJ
Turn-Off Switching Loss	E <sub>off</sub>		-	0.24	-	
Total Switching Loss	E <sub>ts</sub>		-	0.39	-	
<b>Diode CHARACTERISTICS</b>						
Diode Forward Voltage	V <sub>F</sub>	I <sub>F</sub> = 10A	-	1.8	2.1	V
Reverse Recovery Time	T <sub>rr</sub>	I <sub>F</sub> = 10A, di/dt = 200A/us,	-	127	-	ns
Reverse Recovery Charge	Q <sub>rr</sub>		-	286	-	nC
Reverse Recovery Current	I <sub>rrm</sub>		-	4.4	-	A



## TYPICAL PERFORMANCE CHARACTERISTICS

Fig 1. Forward Bias Safe Operating Area

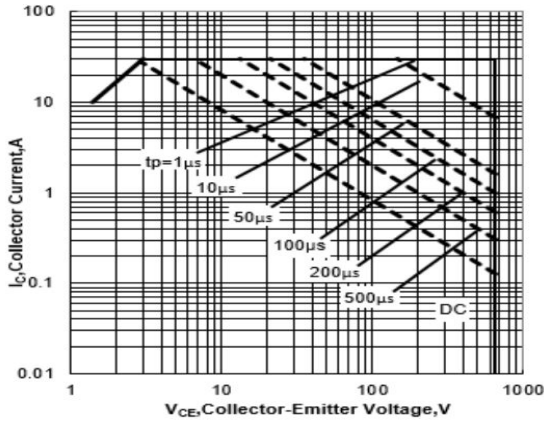

Fig 2. Power Dissipation vs Case Temperature

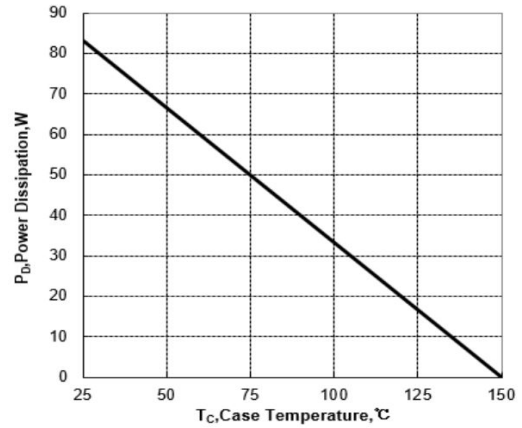

Fig 3. Collector Current vs Case Temperature

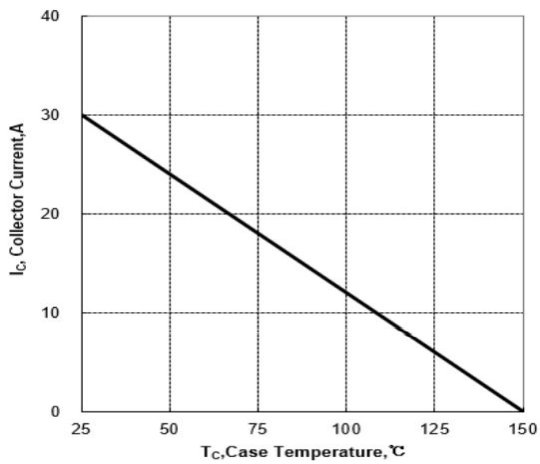

Fig 4. Typical Transfer Characteristics

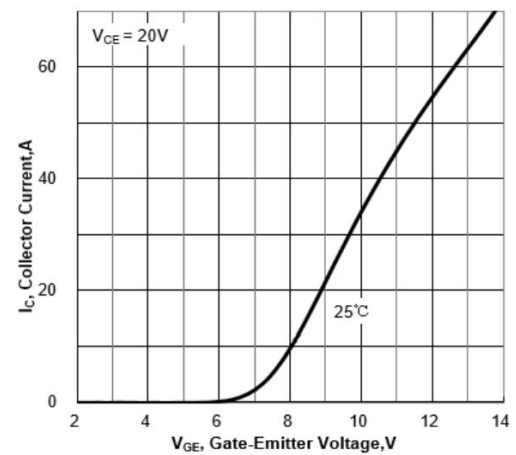

Fig 5. Typical Output Characteristics ( $T_A = 25^{\circ}C$ )

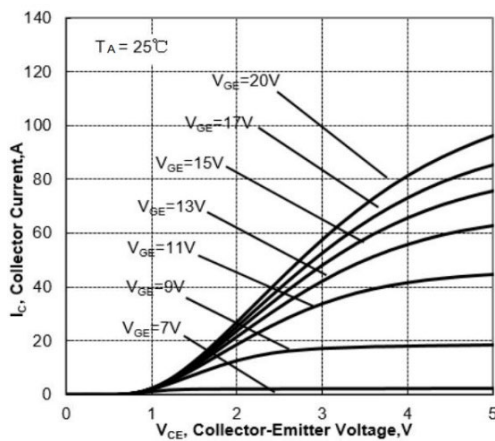

Fig 6. Typical Gate Charge

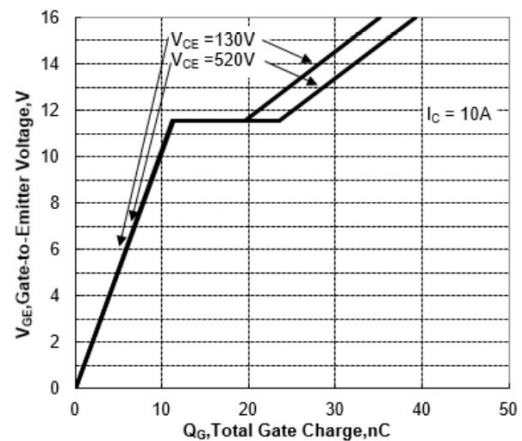



Fig 7. Typical Capacitance vs Collector-Emitter Voltage

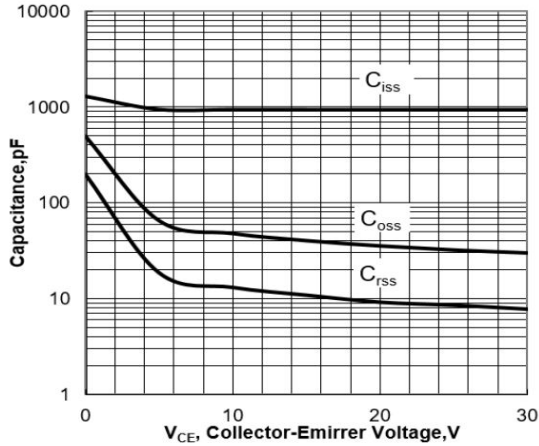

Fig 8. IGBT Transient Thermal Impedance vs Pulse Width

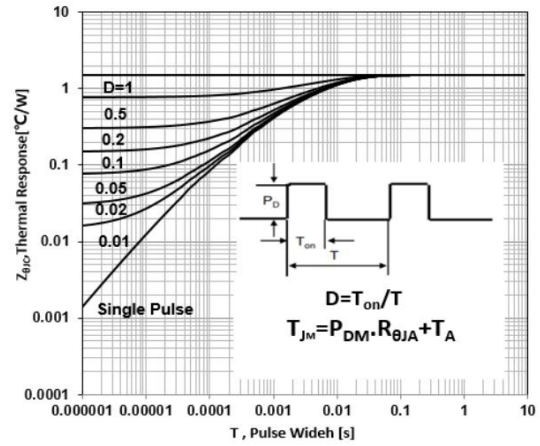

Fig 9. Diode Transient Thermal Impedance vs Pulse Width

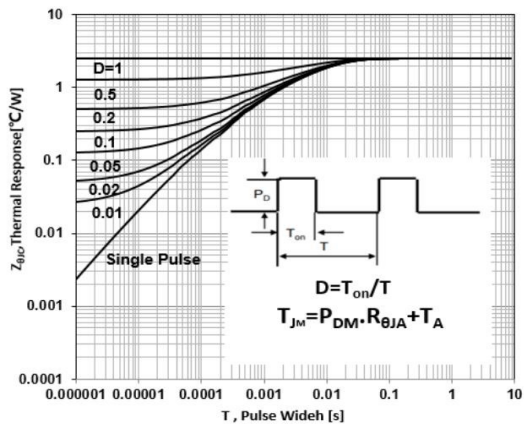

Fig 10. Inductive Switching Test Circuit

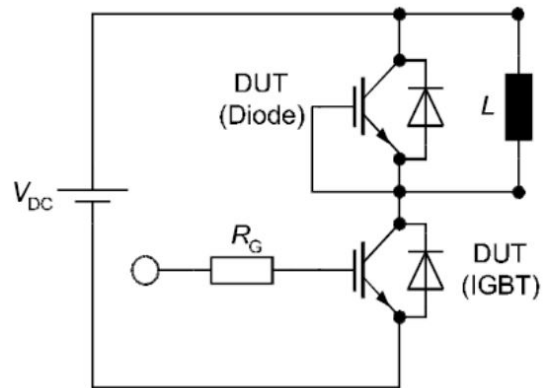

Fig 11. Inductive Switching Waveforms

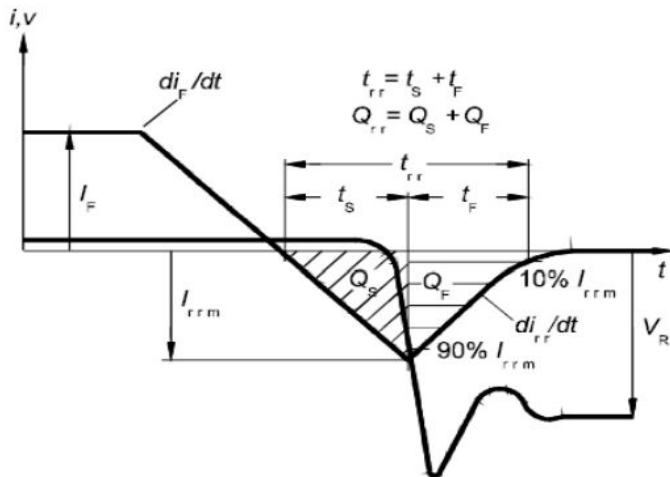



Fig 12. Inductive Switching Waveforms

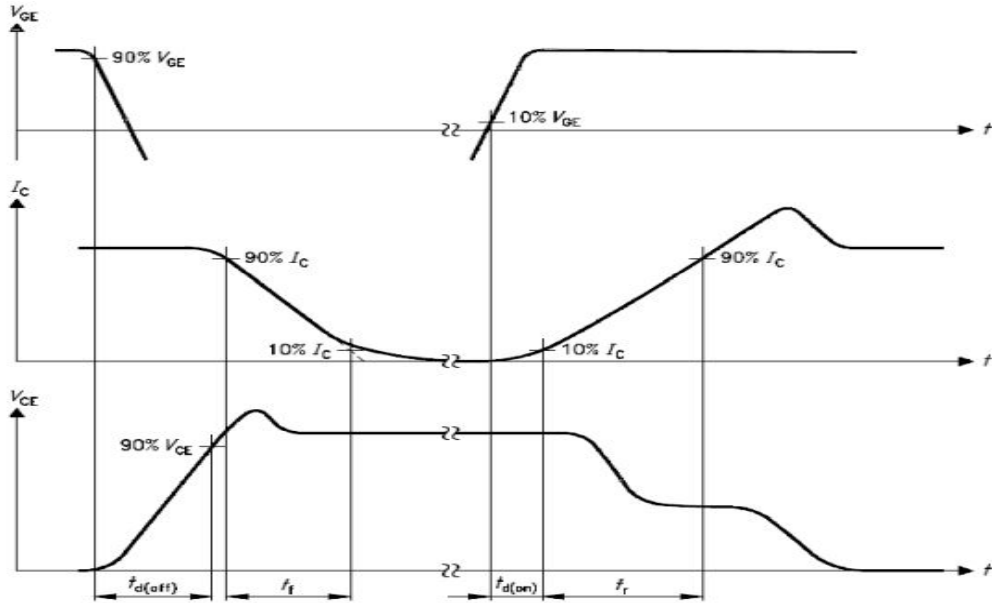
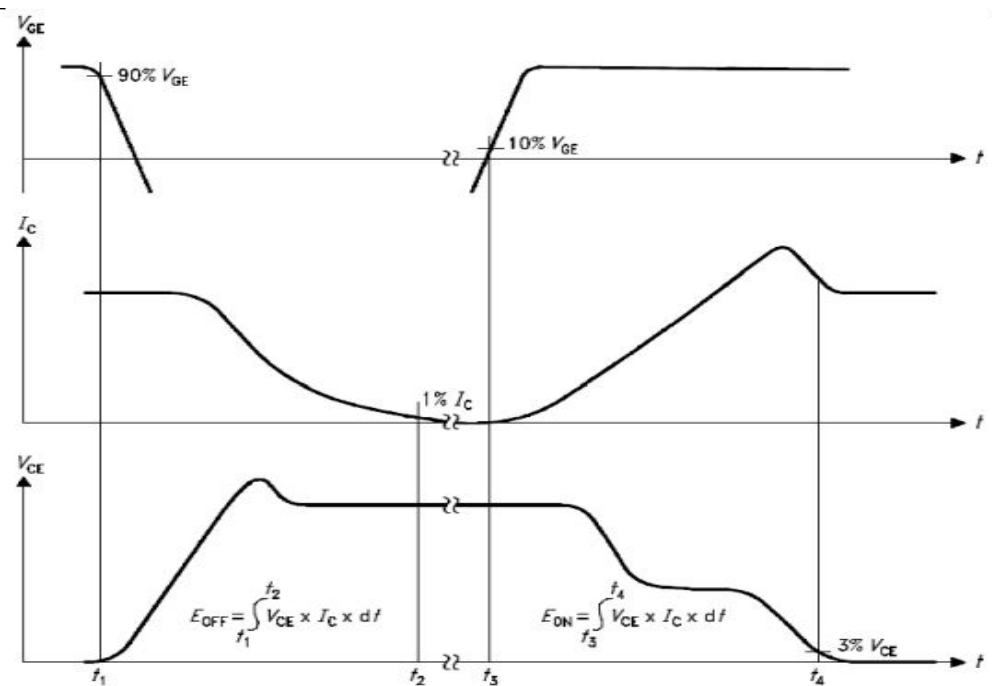

Fig 12. Inductive Switching Waveforms





**PACKAGE INFORMATION**

Dimension in TO-252 (Unit: mm)

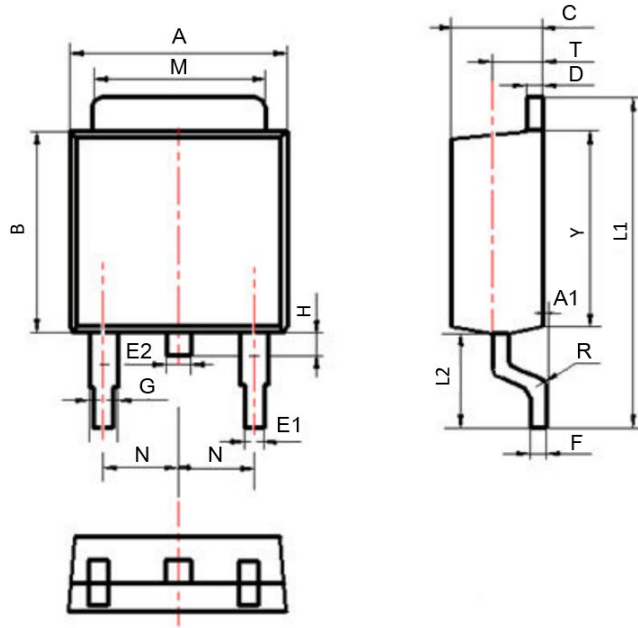

Symbol	Min.	Max.
A	6.30	6.90
A1	0	0.13
B	5.70	6.30
C	2.10	2.50
D	0.30	0.60
E1	0.60	0.90
E2	0.70	1.00
F	0.30	0.60
G	0.70	1.20
L1	9.60	10.50
L2	2.70	3.10
H	0.60	1.00
M	5.10	5.50
N	2.09	2.49
R	0.3	
T	1.40	1.60
Y	5.10	6.30



## **IMPORTANT NOTICE**

AiT Semiconductor Inc. (AiT) reserves the right to make changes to any its product, specifications, to discontinue any integrated circuit product or service without notice, and advises its customers to obtain the latest version of relevant information to verify, before placing orders, that the information being relied on is current.

AiT Semiconductor Inc. integrated circuit products are not designed, intended, authorized, or warranted to be suitable for use in life support applications, devices or systems or other critical applications. Use of AiT products in such applications is understood to be fully at the risk of the customer. As used herein may involve potential risks of death, personal injury, or server property, or environmental damage. In order to minimize risks associated with the customer's applications, the customer should provide adequate design and operating safeguards.

AiT Semiconductor Inc. assumes to no liability to customer product design or application support. AiT warrants the performance of its products of the specifications applicable at the time of sale.