



DESCRIPTION

The AG44272 is a low-voltage, in-phase gate driver designed for driving power MOSFETs and IGBTs. It is fabricated using proprietary latch-up immune CMOS technology, enabling a highly robust monolithic integration.

The AG44272 accepts logic input levels compatible with CMOS and LSTTL outputs down to 3.3 V. The output driver features a wide VCC operating range, undervoltage lockout (UVLO) with hysteresis, and a high-current buffer stage.

The AG44272 is specified for operation over an ambient temperature range of -40°C to +125°C.

AG44272 is available in a SOT23-5 package.

ORDERING INFORMATION

Package Type	Part Number	
SOPT25 SPQ: 3,000pcs/Reel	E5	AG44272E5R
		AG44272E5VR
Note	V: Halogen free Package R: Tape & Reel	
AiT provides all RoHS products		

FEATURES

- CMOS Schmitt trigger input
- In-phase input/output configuration
- Compatible with 3.3 V logic input
- High peak output current capability:
 - Source / Sink current: 2 A / 2 A
- Wide operating supply voltage range: 5 V to 25 V
- High capacitive driving capability
- Wide operating temperature range: -40°C to +125°C
- Undervoltage lockout (UVLO):
 - Rising threshold: 4.0 V
 - Falling threshold: 3.9 V
- Fast switching performance:
 - Turn-on / turn-off delay (Ton/Toff): 25 ns / 25 ns

APPLICATION

- Switching power supplies (SMPS) and DC-DC converters
- General-purpose gate driver applications
- Driving power MOSFETs and IGBTs

TYPICAL APPLICATION CIRCUIT

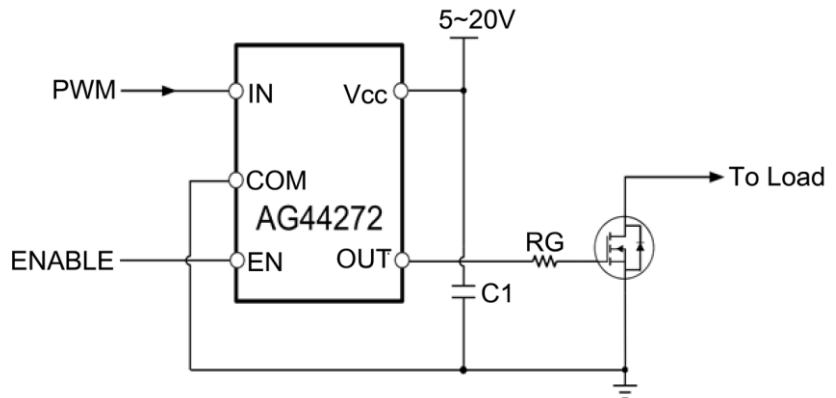

PIN DESCRIPTION

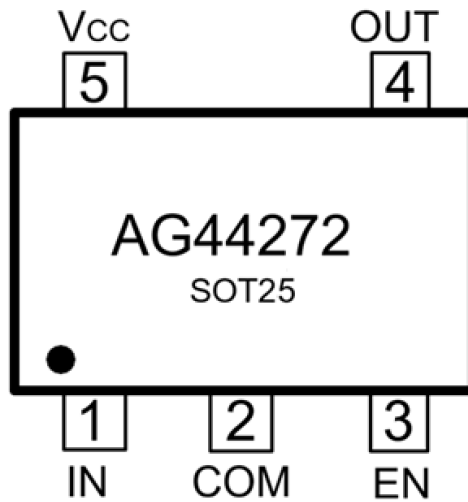

SOT-25, E5
Top View

Pin #	Symbol	Function
1	IN	Logic Input (IN)
2	COM	Ground (GND)
3	EN	Enable Input
4	OUT	Gate Driver Output (OUT)
5	V _{CC}	Supply Voltage (V _{CC})

ABSOLUTE MAXIMUM RATINGS

V _{CC} , Supply Voltage	-0.3V ~ 25V
V _{OUT} , Output Voltage	-0.3V ~ V _{CC} + 0.3V
V _{IN} , Logic Input Voltage	-0.3V ~ V _{CC} + 0.3V
R _{thJA} , Thermal Resistance Junction to Ambient	SOT-23-5 151°C/W
T _J , Junction Temperature	150°C/W



T _s , Storage Temperature	-55°C~150°C
T _L , Lead Temperature (Soldering, 10 seconds)	300°C

Stress beyond above listed “Absolute Maximum Ratings” may lead permanent damage to the device. These are stress ratings only and operations of the device at these or any other conditions beyond those indicated in the operational sections of the specifications are not implied. Exposure to absolute maximum rating conditions for extended periods may affect device reliability.

RECOMMENDED OPERATING CONDITIONS

Parameter	Symbol	Min.	Max.	Units
Power Supply	V _{CC}	5.0	20	V
Output Voltage	V _O	0	V _{CC}	V
Logic input voltage	V _{IN}	0	V _{CC}	V
Environment Ambient Temperature	T _A	-40	125	°C

**ELECTRICAL CHARACTERISTICS**V_{CC} = 15V, T_A = 25°C, unless otherwise specified.

Parameter	Symbol	Conditions	Min	Typ.	Max	Units
Static						
Logic "1"(HIN+LIN) Input Voltage	V _{IH}		2.7	-	-	V
Logic "0" (HIN+LIN) Input Voltage	V _{IL}		-	-	0.8	
EN Input Rising Threshold Voltage	V _{EN+}			2.5		
EN Input Falling Threshold Voltage	V _{EN-}			0.8		
High Level Output Voltage,	V _{OH}		-	-	0.35	
Low Level Output Voltage, V _O	V _{OL}		-	-	0.35	
V _{CC} Supply Current	I _Q		-	280	400	μA
Logic "1" Input V _{CC} Current	I _{IN+}		-	50	100	
Logic "0" Input V _{CC} Current	I _{IN-}		-	-	5	
Output High Short-Circuit Pulse Current	I _{O+}		-	2	-	A
Output Low Short-Circuit Pulse Current	I _{O-}		-	2	-	
V _{CC} UVLO Hysteresis Voltage	V _{CCUVHYS}		-	0.1	-	V
V _{CC} Supply UVLO Threshold	V _{CCU+}		-	4.0	5.0	
	V _{CCU-}		-	3.9	-	
Rise Time	t _R		-	-	30	ns
Fall Time	t _F		-	-	30	
Turn-on Propagation Delay	t _{ON}		-	25	40	
Turn-off Propagation Delay	t _{OFF}		-	25	40	

BLOCK DIAGRAM

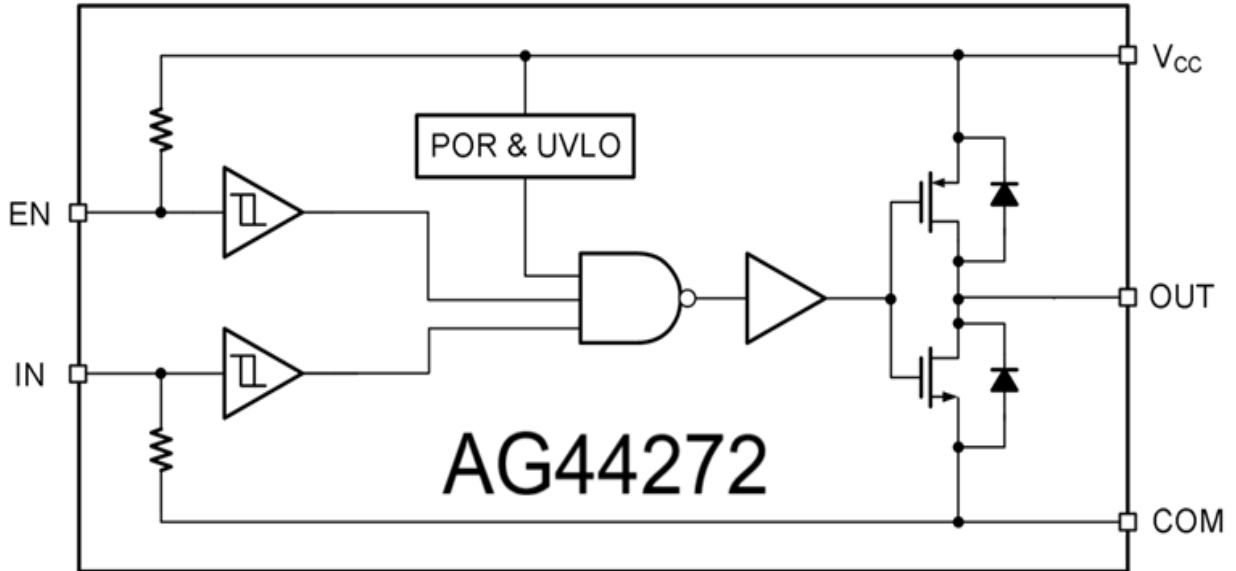

DETAILED INFORMATION

Fig1: AG44272 Input and Output Timing Waveform

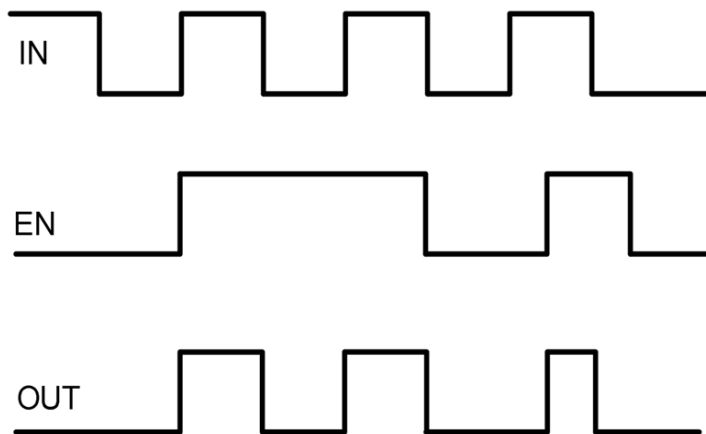
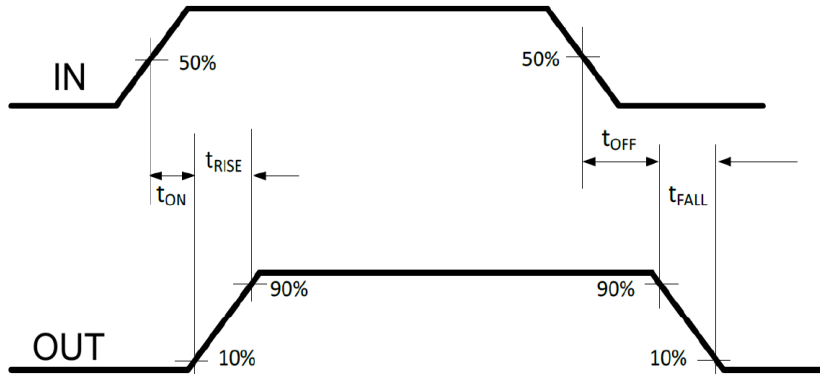

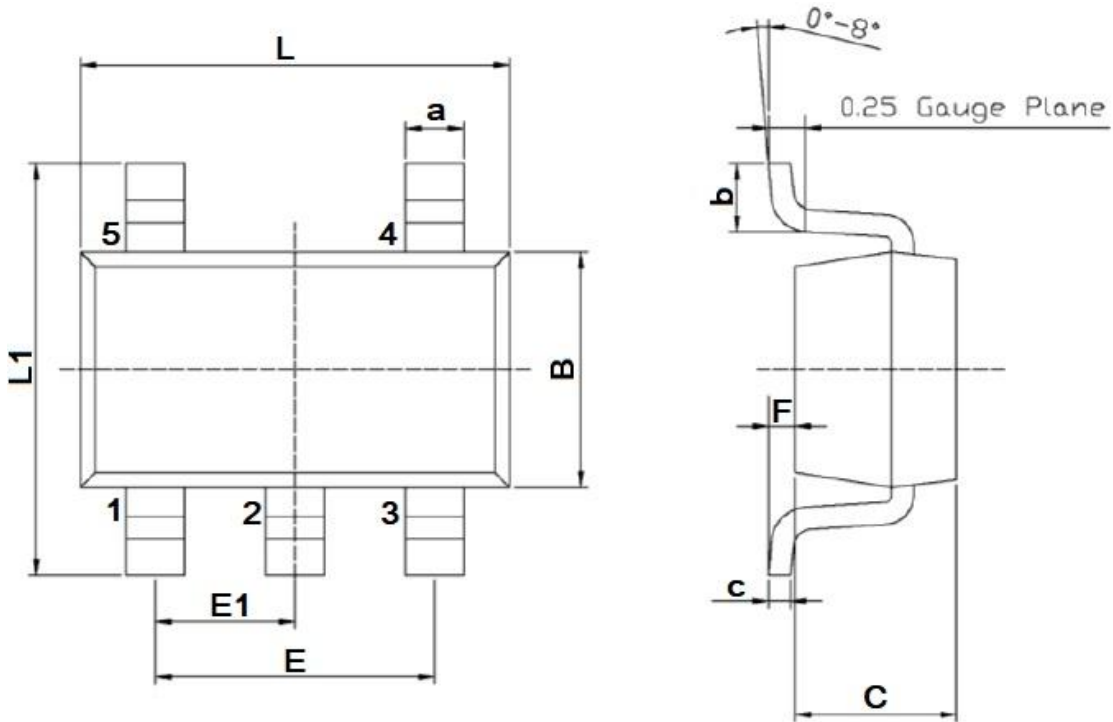

Fig2: Propagation Time Waveform Definition



PACKAGE INFORMATION

Dimension in SOT25 (Unit: mm)



Symbol	Min.	Max.
A	2.820	3.020
B	1.50	1.700
B	0.350	0.550
C	0.900	1.300
C	0.100	0.200
E	1.800	2.000
E1	0.850	1.050
F	0.000	0.15
L	2.820	3.020
L1	2.600	3.000

IMPORTANT NOTICE

AiT Semiconductor Inc. (AiT) reserves the right to make changes to any its product, specifications, to discontinue any integrated circuit product or service without notice, and advises its customers to obtain the latest version of relevant information to verify, before placing orders, that the information being relied on is current.



AiT Semiconductor Inc.'s integrated circuit products are not designed, intended, authorized, or warranted to be suitable for use in life support applications, devices or systems or other critical applications. Use of AiT products in such applications is understood to be fully at the risk of the customer. As used herein may involve potential risks of death, personal injury, or server property, or environmental damage. In order to minimize risks associated with the customer's applications, the customer should provide adequate design and operating safeguards.

AiT Semiconductor Inc. assumes no liability to customer product design or application support. AiT warrants the performance of its products of the specifications applicable at the time of sale.