

**DESCRIPTION**

The BZX84C16-Q is available in SOT-23 package.

**FEATURE**

- AEC-Q101 qualified

**ORDERING INFORMATION**

Package Type	Part Number
SOT-23	BZX84C16-Q
Note	SPQ: 3,000pcs/Reel
AiT provides all RoHS Compliant Products	

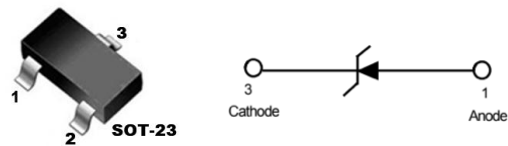
**PIN DESCRIPTION**

PIN#	DESCRIPTION
1	Anode
3	Cathode

**ABSOLUTE MAXIMUM RATINGS**

T<sub>A</sub> = 25°C, unless otherwise noted.

P <sub>D</sub> , Total Device Dissipation, FR-4 Board*	@ T <sub>A</sub> = 25°C	300mW
R <sub>θJA</sub> , Thermal Resistance, Junction-to-Ambient		435°C/W
R <sub>θJC</sub> , Thermal Resistance, Junction-to-Case		190°C/W
T <sub>J</sub> , Junction Temperature Range		-55°C~+150°C
T <sub>STG</sub> , Storage Temperature Range		-55°C~+150°C

Stresses above may cause permanent damage to the device. These are stress ratings only and functional operation of the device at these or any other conditions beyond those indicated in the Electrical Characteristics are not implied. Exposure to absolute maximum rating conditions for extended periods may affect device reliability.

\*Device mounted on an FR-4 PCB, single-sided copper, tin-plated and standard footprint

**ELECTRICAL CHARACTERISTICS**

T<sub>A</sub> = 25°C, unless otherwise noted.

Parameter	Symbol	Conditions	Min.	Typ.	Max.	Unit
Zener Voltage*	V <sub>Z</sub>	I <sub>ZT1</sub> = 5 mA	15.3	16	17.1	V
		I <sub>ZT2</sub> = 1 mA	15.2	-	17	
		I <sub>ZT3</sub> = 20 mA	15.4	-	17.2	
Zener Impedance	Z <sub>ZT</sub>	I <sub>ZT1</sub> = 5 mA	-	-	40	Ω
		I <sub>ZT2</sub> = 1 mA	-	-	200	
		I <sub>ZT3</sub> = 20 mA	-	-	20	
Reverse Leakage Current	I <sub>R</sub>	V <sub>R</sub> =11.2V	-	-	0.05	μA
Capacitance	C	V <sub>R</sub> =0, f=1MHz	-	21.5	-	pF
Temperature Coefficient	θ <sub>VZ</sub>	I <sub>ZT1</sub> = 5mA	10.4	-	14	mV/°C

\* Zener voltage is measured with a pulse test current I<sub>Z</sub> at an ambient temperature of 25°C.



## ELECTRICAL CHARACTERISTICS CURVES

Fig 1. IR vs. VR

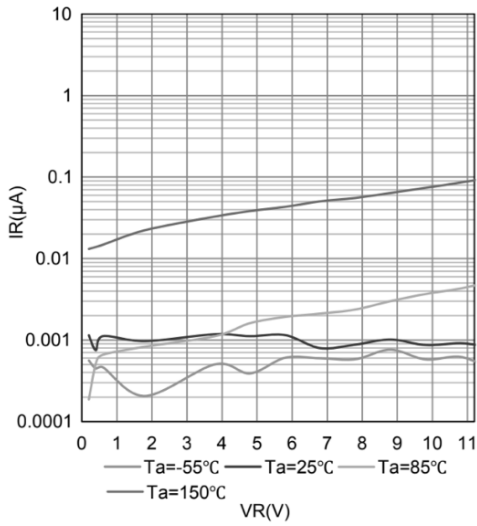

Fig 2. IZ vs. VZ

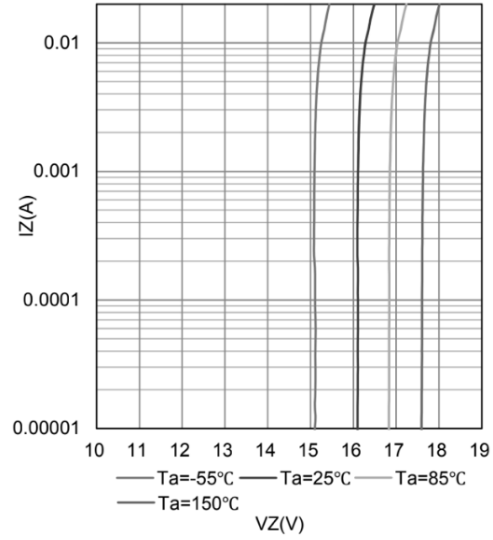

Fig 3. IF vs. VF

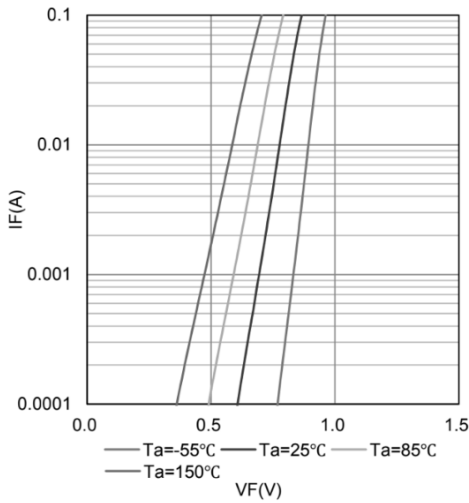
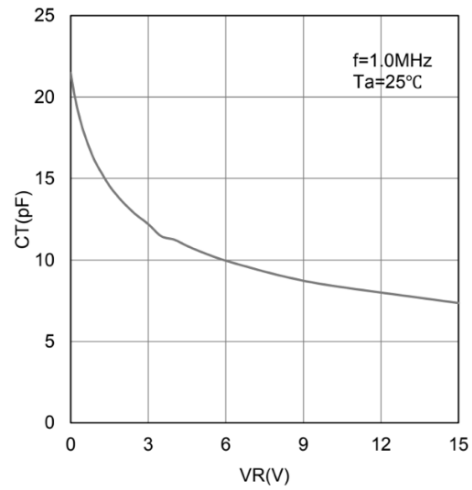

Fig 4. Capacitance





**PACKAGE INFORMATION**

Dimension in SOT-23 Package (Unit: mm)

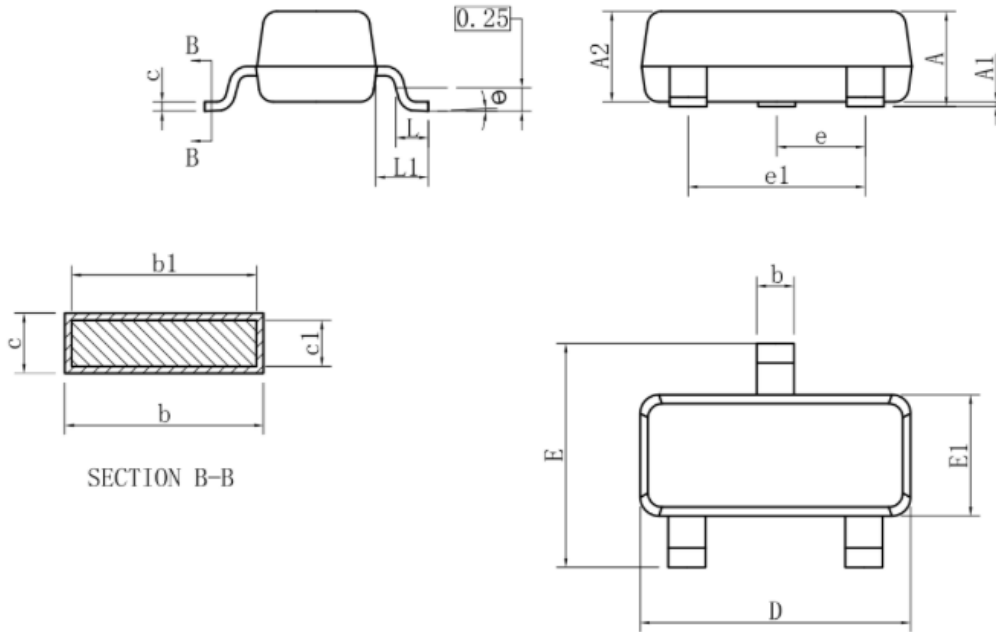

SECTION B-B

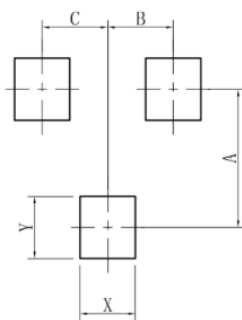

The recommended mounting pad size

SOT-23	
DIM	(mm)
X	0.80
Y	0.90
A	2.00
B	0.95
C	0.95

SYMBOL	MIN	MAX
A	0.89	1.12
A1	0.01	0.10
A2	0.88	1.02
b	0.30	0.50
b1	0.30	0.45
c	0.08	0.20
c1	0.08	0.16
D	2.80	3.04
E	2.10	2.64
E1	1.20	1.40
e	0.95BSC	
e1	1.90BSC	
L	0.40	0.60
L1	0.54REF	
θ	0°	8°



## **IMPORTANT NOTICE**

AiT Semiconductor Inc. (AiT) reserves the right to make changes to any its product, specifications, to discontinue any integrated circuit product or service without notice, and advises its customers to obtain the latest version of relevant information to verify, before placing orders, that the information being relied on is current.

AiT Semiconductor Inc. integrated circuit products are not designed, intended, authorized, or warranted to be suitable for use in life support applications, devices or systems or other critical applications. Use of AiT products in such applications is understood to be fully at the risk of the customer. As used herein may involve potential risks of death, personal injury, or server property, or environmental damage. In order to minimize risks associated with the customer's applications, the customer should provide adequate design and operating safeguards.

AiT Semiconductor Inc. assumes to no liability to customer product design or application support. AiT warrants the performance of its products of the specifications applicable at the time of sale.