



DESCRIPTION

The DF005S_DF10S are available in DFS package.

MECHANICAL DATA

- Case: Molded plastic
- Terminals: Plated leads solderable per MIL-STD-202, Method 208
- Mounting Position: Any
- Weight:0.33 grams (approx.)
- Polarity: Marked on body

ORDERING INFORMATION

Package Type	Part Number
DFS	DF005S
	DF01S
	DF02S
	DF04S
	DF06S
	DF08S
	DF10S
Note	SPQ: 1,500pcs/Reel
AiT provides all RoHS Compliant Products	

FEATURE

- The plastic material used carries Underwriters Laboratory flammability recognition 94V-0
- Surge overload ratings to 30 amperes
- High temperature soldering guaranteed 260°C/5 seconds at 5 lbs (2.3kg) tension
- Ideal for printed circuit board application

PIN DESCRIPTION

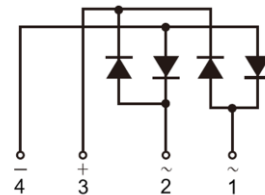

1. Input Pin (-)
2. Input Pin (-)
3. Output Anode (+)
4. Output Cathode (-)

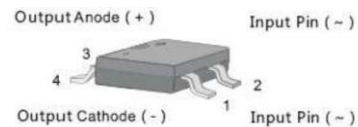

**ABSOLUTE MAXIMUM RATINGS AND ELECTRICAL CHARACTERISTICS**

Ratings at 25°C ambient temperature unless otherwise specified. Single phase, half wave, 60Hz, resistive or inductive load, for capacitive load, derate by 20 %.

Parameter	Symbol	DF005S	DF01S	DF02S	DF04S	DF06S	DF08S	DF010S	Unit
Maximum Repetitive Peak Reverse Voltage	V_{RRM}	50	100	200	400	600	800	1000	V
Maximum RMS Bridge Input Voltage	V_{RMS}	35	70	140	280	420	560	700	V
Maximum DC Blocking Voltage	V_{DC}	50	100	200	400	600	800	1000	V
Maximum Average Forward Rectified Current Output Current at $T_A=40\text{ C}$	$I_{F(AV)}$	1							A
Peak Forward Surge Current Single Sine-Wave Superimposed on Rated Load (JEDEC Method)	I_{FSM}	30							A
Rating for Fusing ($t < 8.3\text{ms}$)	I^2t	10							A ² sec
Maximum Instantaneous Forward Voltage Drop Per Leg at 1.0A	V_F	1.1							V
Maximum DC Reverse Current at Rated DC Blocking Voltage Per Element	$T_A=25\text{ }^\circ\text{C}$	I_R							μA
	$T_A=125\text{ }^\circ\text{C}$								
Typical Junction Capacitance Per Element ⁽²⁾	C_J	25							pF
Typical Thermal Resistance Per Element ⁽¹⁾	$R_{\theta JA}$	110							°C/W
Operating Junction Temperature Range	T_J	-55 ~ + 150							°C
Storage Temperature Range	T_{STG}	-55 ~ + 150							°C

Stresses above may cause permanent damage to the device. These are stress ratings only and functional operation of the device at these or any other conditions beyond those indicated in the Electrical Characteristics are not implied. Exposure to absolute maximum rating conditions for extended periods may affect device reliability.

(1) Thermal resistance from Junction to Ambient on P.C. board mounting.

(2) Measured at 2.0MHz and applied reverse voltage of 4.0 volts.



TYPICAL PERFORMANCE CHARACTERISTICS

Fig 1. Derating Curve for Output Rectified Current

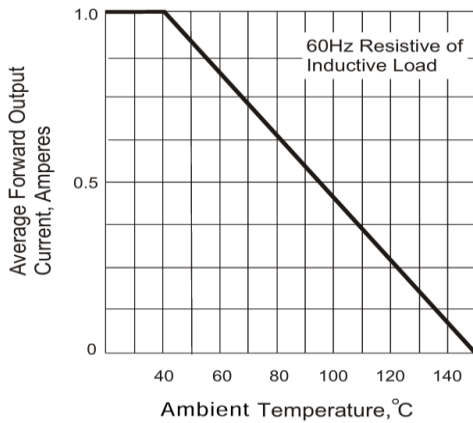

Fig 2. Maximum Non-repetitive Peak Forward Surge Current

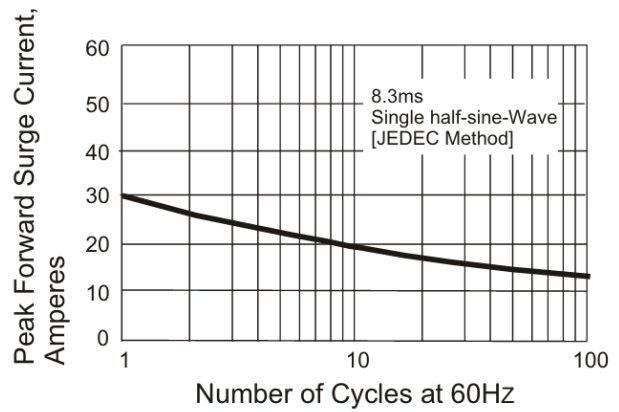

Fig 3. Typical Instantaneous Forward Characteristics

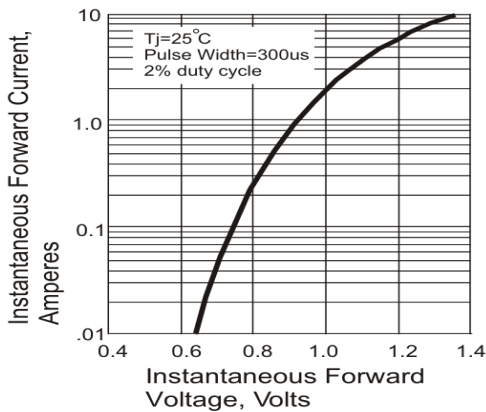

Fig 4. Typical Revers Characteristics

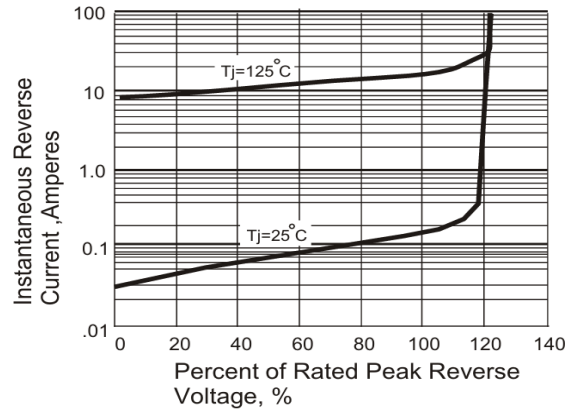
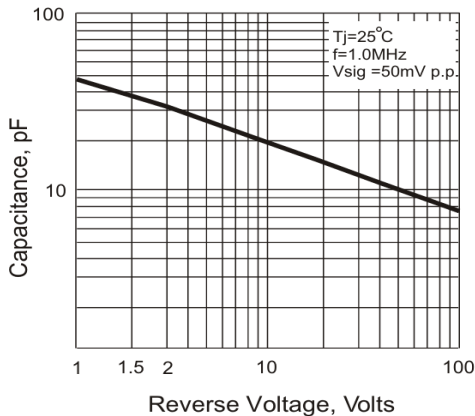

Fig 5. Typical Junction Capacitance





PACKAGE INFORMATION

Dimension in DFS Package (Unit: mm)

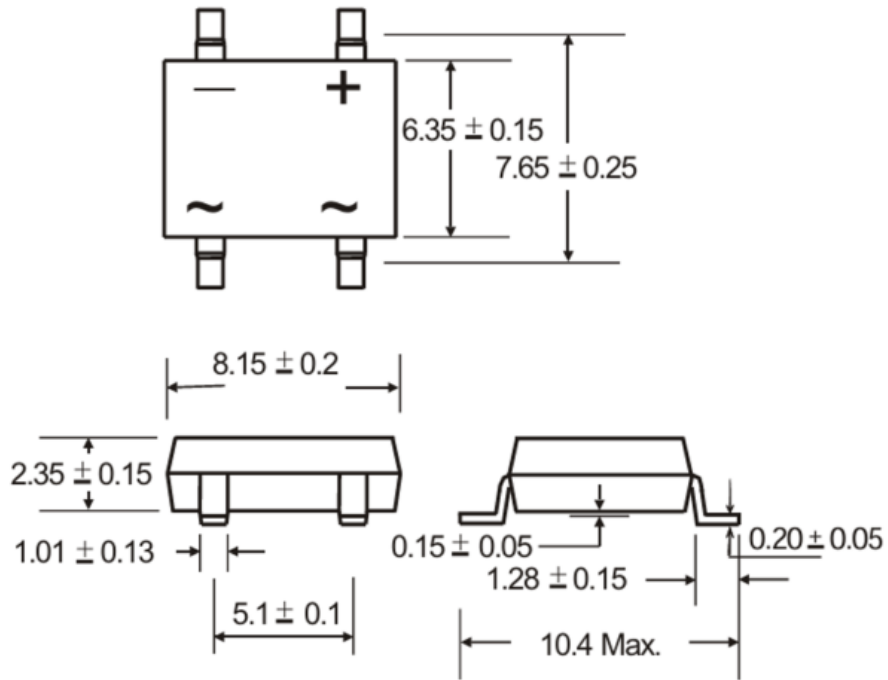



IMPORTANT NOTICE

AiT Semiconductor Inc. (AiT) reserves the right to make changes to any its product, specifications, to discontinue any integrated circuit product or service without notice, and advises its customers to obtain the latest version of relevant information to verify, before placing orders, that the information being relied on is current.

AiT Semiconductor Inc. integrated circuit products are not designed, intended, authorized, or warranted to be suitable for use in life support applications, devices or systems or other critical applications. Use of AiT products in such applications is understood to be fully at the risk of the customer. As used herein may involve potential risks of death, personal injury, or server property, or environmental damage. In order to minimize risks associated with the customer's applications, the customer should provide adequate design and operating safeguards.

AiT Semiconductor Inc. assumes to no liability to customer product design or application support. AiT warrants the performance of its products of the specifications applicable at the time of sale.